

# 30" Stainless Steel Electric Cooktop with Touch Control

## 500 Series - Black and Stainless Steel

### NET5054UC

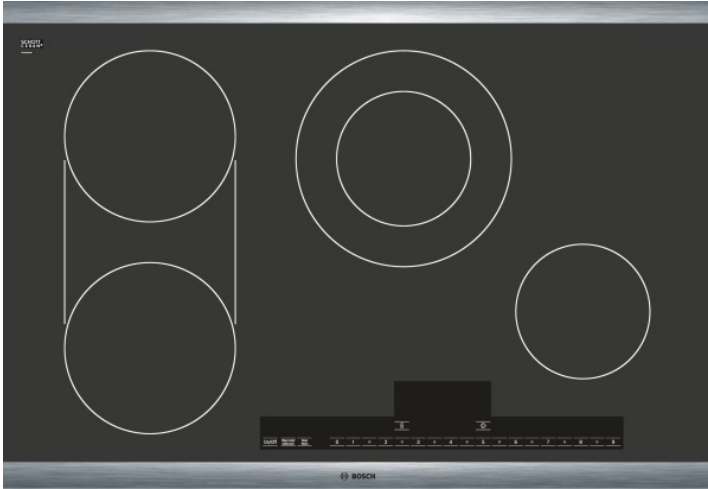

#### Features and Benefits

##### Key Features

- PreciseSelect™ - Direct Cooking Level Selection (17 Settings)
- Sleek Touch Control Panel Offers a Choice of 17 Settings for Unprecedented Temperature Control.
- Bridge Element Accommodates Oblong Pans and Multiple Diameter Sized Cookware
- Dual Element Offers the Capability to use Multiple Pan Sizes

##### Design

- Sleek Touch Control Panel Offers a Choice of 17 Settings for Unprecedented Temperature Control.
- Front and Back Stainless Steel Strip for a Premium Look

##### Performance

- Bridge Element Accommodates Oblong Pans and Multiple Diameter Sized Cookware
- Dual Element Offers the Capability to use Multiple Pan Sizes

##### Convenience

- PreciseSelect™ - Direct Cooking Level Selection (17 Settings)
- Clean Lock - Prevents Unwanted Changing of Settings while Cleaning Spill-Overs.
- Keep Warm function allows meals to remain ready to serve
- 2-Level Heat Indicator - Warns if Cooktop is Warm or Hot
- ChildLock - Prevents the Cooktop from Being Accidentally Switched on. Locks Temperature Settings if in Use.

Notes: All height, width and depth dimensions are shown in inches. \*Please refer to installation instructions prior to making cutout. BSH reserves the absolute and unrestricted right to change product materials and specifications, at any time, without notice. Consult the product's installation instructions for final dimensional data and other details. Applicable product warranty can be found in a accompanying product literature or you may contact your account manager for further details.

For more information on our entire line of products, go to [boschappliances.com](http://boschappliances.com) or call 1-800-944-2904.  
Copyright ©2013 BSH Home Appliances Corporation. All rights reserved. Bosch is a registered trademark of Robert Bosch GmbH.

Litho Date: 04/2013



# 30" Stainless Steel Electric Cooktop with Touch Control

## 500 Series - Black and Stainless Steel

### NET5054UC

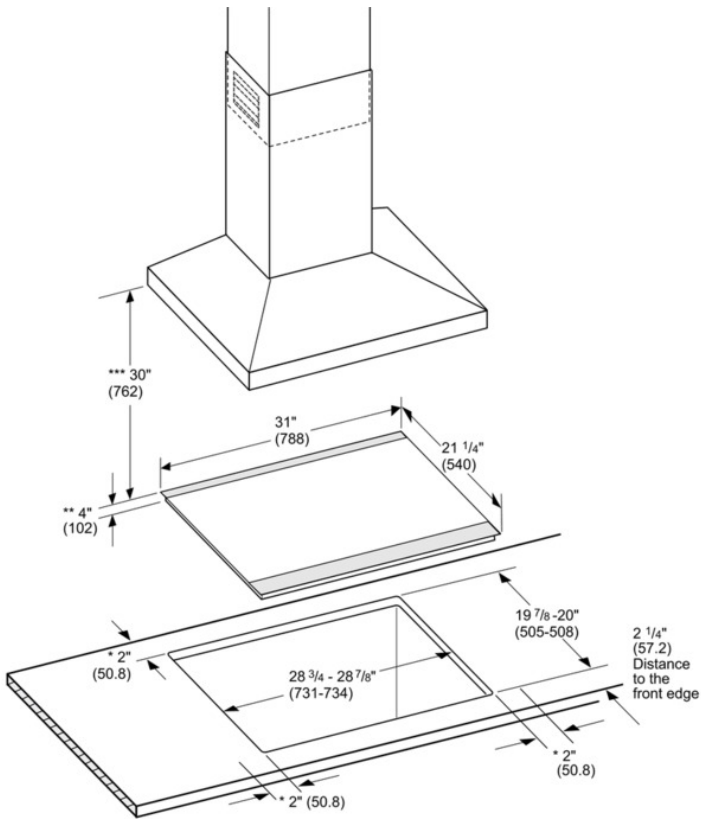

- \* Minimum distance from the cooktop cutout to the wall
- \*\* Maximum cutout depth
- \*\*\* Minimum distance between the cooktop surface and lower edge of the exhaust hood.

Dimensions in inches (mm)

### Features

Knob Material	
Sealed Burners	No
Burners with booster	
Type of grate	
Total BTU load	
LP Gas Connection Rating (BTU)	
Power of 1st heating element (kW in boost)	
Dimension of 1st heating element (in)	7"
Power of 2nd heating element (kW in boost)	
Dimension of 2nd heating element (in)	7"
Power of 3rd heating element (kW in boost)	
Dimension of 3rd heating element (in)	6", 9"
Power of 4th heating element (kW in boost)	
Dimension of 4th heating element (in)	6"
Power of 5th heating element (kW in boost)	
Dimension of 5th heating element (in)	
Power of 6th heating element (kW in boost)	
Dimension of 6th heating element (in)	

### Technical Specification

UPC code	825225867623
Variant color	Black
Energy source	Electric
Gas type	
Alternative gas type	
Watts (W)	7700
Current (A)	32
Volts (V)	240/208
Frequency (Hz)	60
Approval certificates	CUL
Power cord length (in)	
Plug type	No plug
Required cutout size (HxWxD) (in)	4" x 28 7/8" x 20"
Minimum distance from counter front (in)	2 1/4"
Minimum distance from rear wall (in)	2"
Overall appliance dimensions (HxWxD) (in)	1/4"+4" x 31" x 21 1/4"
Product packaging dimensions (HxWxD) (in)	7 7/8" x 37 3/8" x 24"
Net weight (lbs)	27
Gross weight (lbs)	35
Total number of cooktop burners	4

Notes: All height, width and depth dimensions are shown in inches. \*Please refer to installation instructions prior to making cutout. BSH reserves the absolute and unrestricted right to change product materials and specifications, at any time, without notice. Consult the product's installation instructions for final dimensional data and other details. Applicable product warranty can be found in a accompanying product literature or you may contact your account manager for further details.

For more information on our entire line of products, go to [boschappliances.com](http://boschappliances.com) or call 1-800-944-2904.

Copyright ©2013 BSH Home Appliances Corporation. All rights reserved. Bosch is a registered trademark of Robert Bosch GmbH.

Litho Date: 04/2013

