



BBN3 Series



STAINLESS
30"
BBN3306SS

The BBN3 powerpack insert series is ideal for cabinet installations. The integrated one-piece design protects the full bottom of your cabinetry with a flush appearance and depth adjustability. Bright LED lighting enhances your cooking experience, while the 4-speed back-lit soft touch control makes operation easy.

- 650 MAX Blower CFM, >1.0 sone at normal speed.
- Four-speed back-lit soft touch control.
- Bright 2-level LED lighting modules illuminate evenly and are tested in cooking environments to ensure long life without dimming.
- 10-minute delay off function keeps hood running after cooking to ensure smoke and odors have cleared the environment.
- EZ1 clips make it easy for single-person installation.
- Code ready technology adjusts the HVI CFM down to 400 or 300 to meet make-up air codes.
- Easy-to-clean, fully enclosed bottom with dishwasher-safe, aluminum-mesh filter.
- Optional non-duct operation using HARKBN30 non-duct kit and charcoal filter (sold separately).
- Works with optional Universal Make-up Air Dampers.
- Stainless liner extension accommodates up to 13" deep cabinets. Extensions available to accommodate cabinets up to 15" deep.
- ADA compliant, remote operation is possible using a standard UL approved wall switch. Requires ADA adapter kit, HAWRK5 (sold separately).

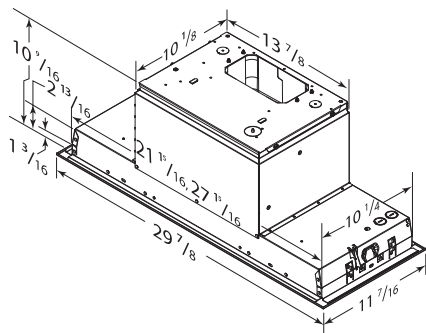

SPECIFICATIONS

Widths	MAX Blower CFM*	Blower	Sones†	Volts	Amps	Duct
29-7/8"	650	Internal	0.5	120	2.3	3-1/4" x 10" (V, H) or 6" RD or 8" RD

* MAX Blower CFM indicates hood blower performance in open air. Find HVI rated performance for this model in the product specification sheet at Broan-NuTone.com

† Sones at normal (or working) speed.

OPTIONAL ACCESSORIES

Non-Duct Kit	Non-Duct Charcoal Filter	Replacement Aluminum Filter	LED	Make-Up Air Dampers	Fresh Air Inlets	Liner Extensions	ADA Adapter Kit
HARKBN30	S99010464-130	S99010400-130	Included	MD6TU MD8TU MD10TU	641FA 643FA 610FA	HADTBN30	HAWRK5



BROAN-NUTONE.COM | 800-558-1711 | 926 WEST STATE STREET, HARTFORD, WISCONSIN 53027