

INSTALL THE HOOD (Non-Ducted Installation Only)

NON-DUCT OPTION AVAILABLE ONLY IN THE U. S.

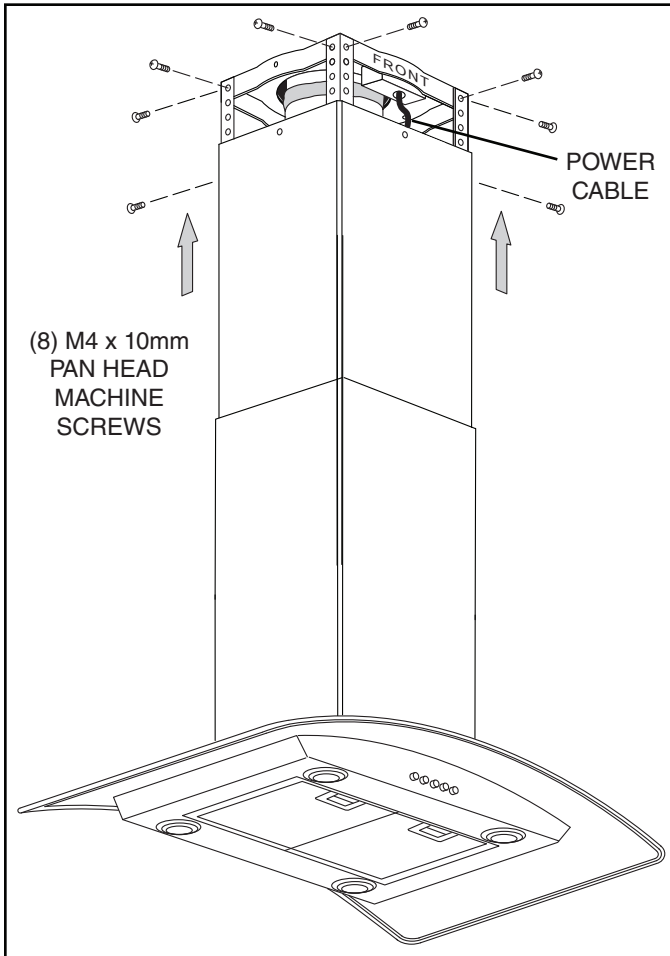

(8) M4 x 10mm
PAN HEAD
MACHINE
SCREWS

POWER
CABLE

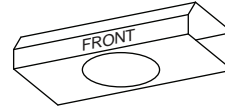
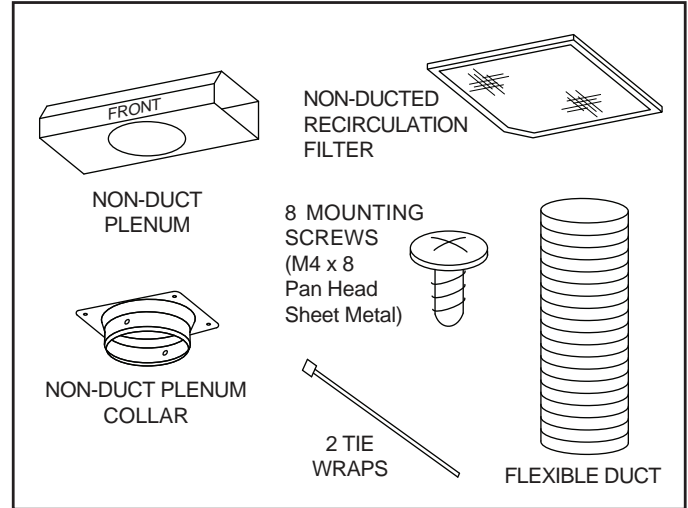

NON-DUCT
PLENUM

NON-DUCTED
RECIRCULATION
FILTER

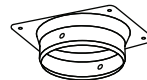
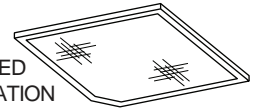

NON-DUCT PLENUM
COLLAR

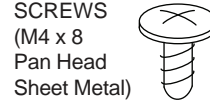

8 MOUNTING
SCREWS
(M4 x 8
Pan Head
Sheet Metal)

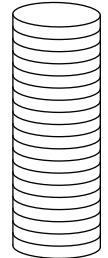

FLEXIBLE DUCT

2 TIE
WRAPS

NOTE:

Non-ducted installations require Non-Duct kit; model RK59 (purchased separately).

Do not use plastic or rigid metal duct.

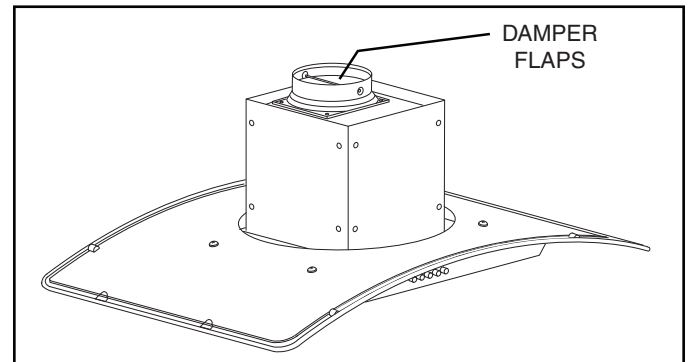

DAMPER
FLAPS

1. Remove the damper flaps from the damper / duct connector and discard flaps.

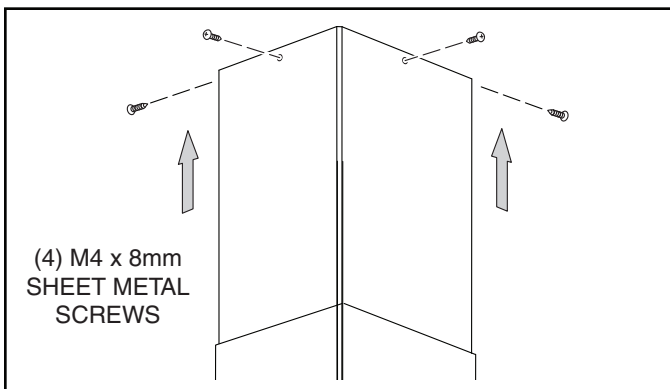

(4) M4 x 8mm
SHEET METAL
SCREWS

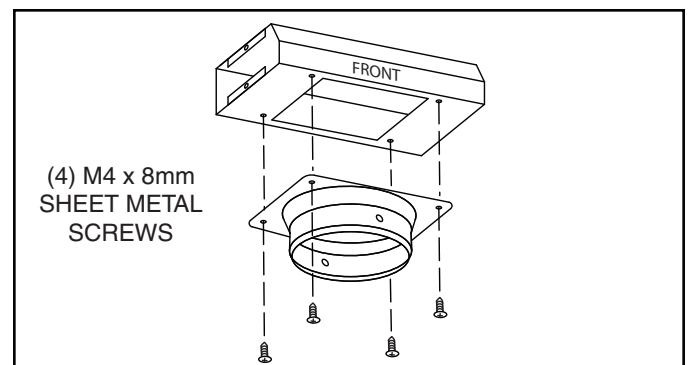

(4) M4 x 8mm
SHEET METAL
SCREWS

2. Attach non-duct collar to non-duct plenum using (4) M4 x 8mm sheet metal screws.

7. Attach the hood assembly to the ceiling bracket using (8) M4 x 10mm machine screws (2 for each support leg).
8. Connect metal duct to ceiling duct and seal with duct tape.
9. Connect power cable to house wiring inside of electrical outlet box. Black to Black, White to White, and Green to Green or Bare wires. Secure power cable to wiring box with appropriate connector and re-attach outlet box cover.

10. Slide the inner flue up to the ceiling and secure with (4) M4 x 8mm sheet metal screws.
11. Remove the protective coating from the hood and the outer flue.

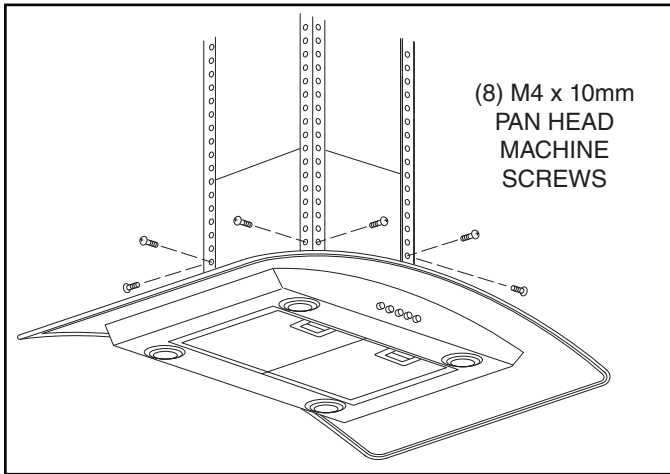

1. Assemble (4) angle brackets to the hood using (8) M4 x 10mm pan head machine screws (2 for each angle bracket).

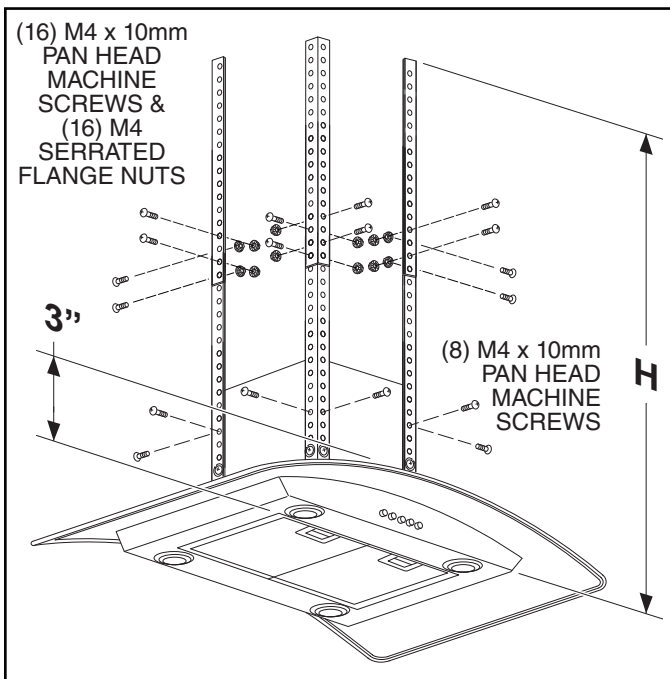

2. Determine dimension "H" based upon ceiling height and height of hood installation above cooktop:

8-ft. ceiling	Hood 30" above cooktop	H = 30"
	Hood 30½" above cooktop	H = 29½"
9-ft. ceiling	Hood 30" above cooktop	H = 42"
	Hood 36" above cooktop	H = 36"
10-ft. ceiling	Hood 30" above cooktop	H = 54"
	Hood 36" above cooktop	H = 48"

For 10-ft. ceilings: Purchase a 10-ft. flue extension (Model FXN59SS) which includes (4) additional angle mounting brackets, (1) longer upper flue, and additional mounting hardware.

3. Attach the upper set of (4) angle brackets to the outside of the lower angle brackets according to dimension "H". Use (16) M4 x 10mm pan head machine screws and (16) M4 serrated flange nuts (4 at each angle bracket connection).
4. Attach the angle bracket assemblies to the upper hood mounting locations using (8) M4 x 10mm pan head machine screws (2 for each angle bracket).

For 10-ft. ceilings: Attach a third set of (4) angle brackets to the inside of the second set of angle brackets using hardware supplied.

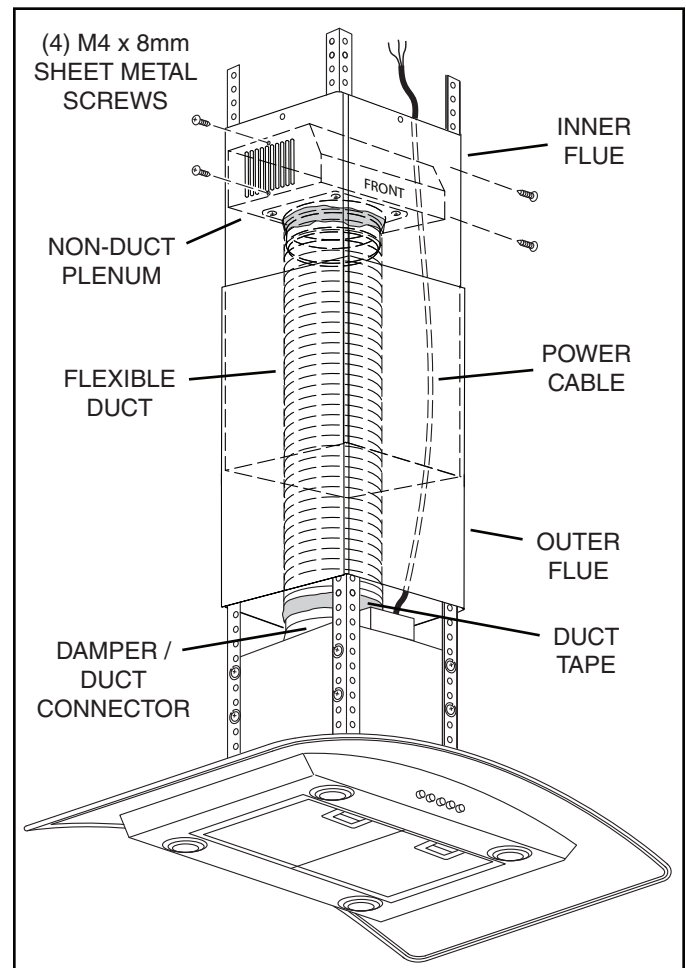

5. Measure the length of 6" round flexible duct required from the damper / duct connector to the ductwork rough-in in the ceiling. Connect the duct to the damper / duct connector, secure with tie wrap and seal with duct tape.
6. Attach the aluminum flexible duct to the non-duct plenum collar. Make sure non-duct plenum "front" is facing front of hood. Secure with tie wrap and seal with duct tape.
7. Remove the protective coating from the inner the flue. Turn the inner flue so that the louvers are at the top. Carefully slide the inner flue down into the outer flue. Slide the flues over the angle brackets. Make sure the side marked "front" faces the control side of the hood. Feed the power cable up through the flues.
8. Pull the inner flue up and attach the non-duct plenum with collar to the upper flue using (4) M4 x 8mm sheet metal screws.

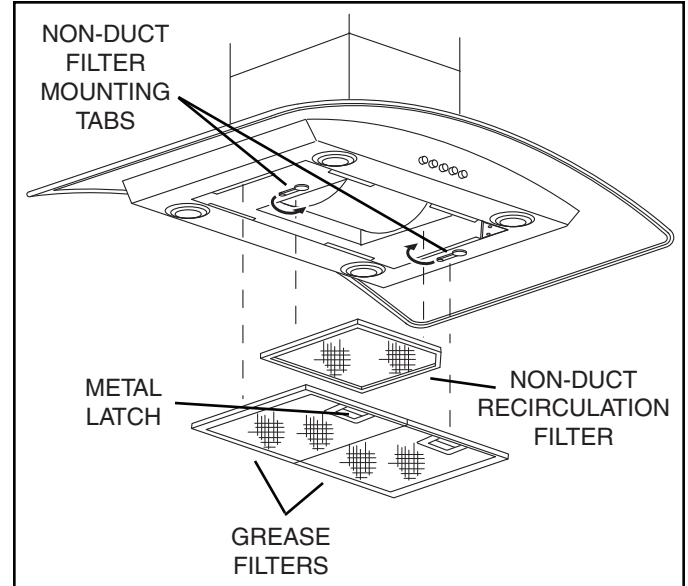
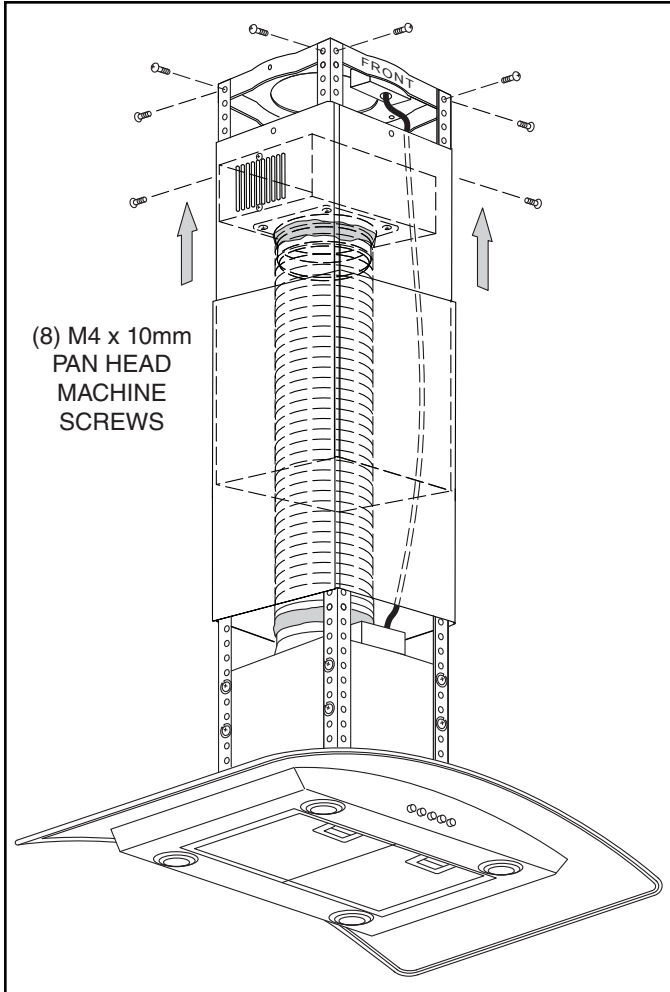

13. Remove the grease filters by pulling down the metal latch tab and tilting the filters downward to remove.
14. Install the non-duct recirculation filter as shown. Turn mounting tabs on hood to secure filter.
15. Reinstall grease filters by aligning rear filter tabs with slots in the hood. Pull down the metal latch tab, push filter into position and release. Make sure filters are securely engaged after installation.

9. Attach the hood assembly to the ceiling bracket using (8) M4 x 10mm machine screws (2 for each support leg).
10. Connect power cable to house wiring. Black to Black, White to White, and Green to Green or Bare wires. Secure power cable to wiring box with appropriate connector.

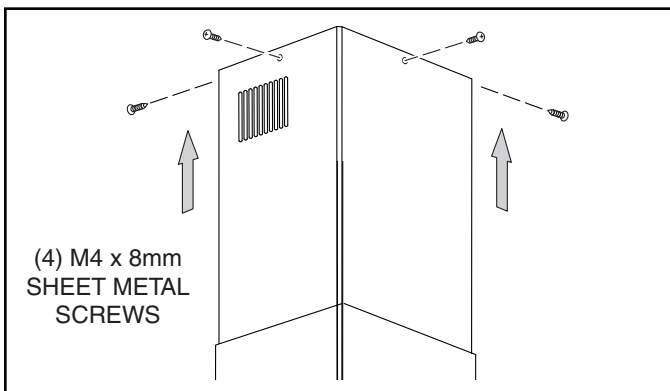

11. Slide the inner flue up to the ceiling and secure with (4) M4 x 8mm sheet metal screws.
12. Remove the protective coating from the hood and the outer flue.