



# 48" ISLAND CHIMNEY HOOD

DHI482



## GENERAL PROPERTIES

FINISH: STAINLESS STEEL

## OPTIONAL ACCESSORIES

RECIRCULATION KIT FOR DHI482: AVDI2

## NUMBER OF MOTORS

(2) DOUBLE BLOWER: 1200 CFM

## TECHNICAL INFORMATION

CIRCUIT REQUIREMENTS: 120VAC, 15AMP, GROUNDED DEDICATED, 3-WIRE CIRCUIT

TOTAL CONNECTED LOAD: 120VAC/60HZ

MAX CURRENT DRAW: 6.8 AMPS

SHIPPING WEIGHT: 169 LBS

## PRODUCT DIMENSIONS

ISLAND DIMENSIONS (H X W X D) (IN.): 28"-36" X 48" X 30"

## DHICH / DHI MODEL

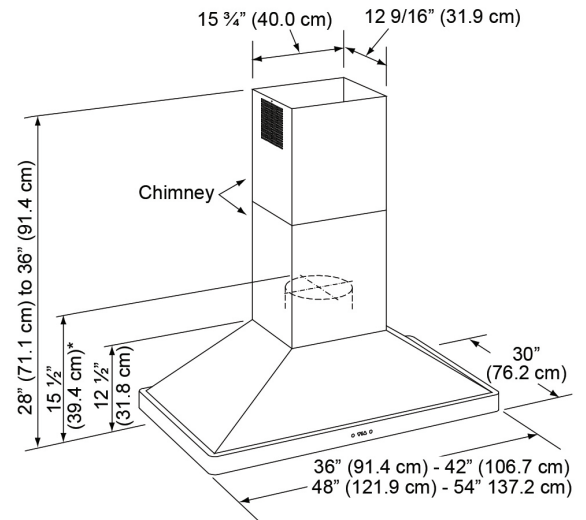

## FEATURES & BENEFITS

- 8" diameter exhaust. Can accommodate up to a 10" duct.
- Squirrel cage style blower. 4 blower speeds.
- Auto off setting after 4 hours.
- Blue illuminated electronic control panel.
- 10 minute Timer (motor runs for 10 minutes and then automatically shuts off).
- 20 watt halogen lights (can be used w/ 10, 20, or 30w bulbs)
- Easy-to-clean Baffle Filter System, dishwasher safe.
- Must order both DHICH and DHI model numbers

## DHICH CEILING MOUNTING BRACKET

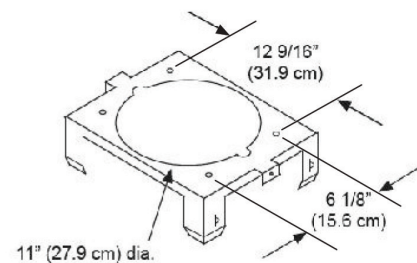

\*\*Warranty: Limited, parts and labor for one year