



24-INCH FREEZER COLUMN, PANEL-READY

DRZ24980LAP | DRZ24980RAP



PRODUCT FEATURES

- Full height door with true flush cabinet integration without exposed venting grille
- SteelCool™ Stainless Steel Interior illuminated by 3DLighting™
- Push-To-Open™ Door Assist opens the door upon a slight push for a luxuriously convenient experience
- Dual Icemaker with Standard and Cocktail Ice™
- Best-in class food preservation with dedicated evaporator/ compressor and Precise Cooling Technology

TEMPERATURE RANGES

| | |
|------------------------|----------------------------|
| FREEZER | °F (-15°C) TO -8°F (-23°C) |
| FREEZER - POWER FREEZE | -8°F (-23°C) |

DIMENSIONS & WEIGHT

| | |
|----------------------------------------|-------------------------|
| APPLIANCE DIMENSIONS (W X H X D) (IN.) | 23 3/4" X 83 3/8" X 25" |
| REQUIRED CUTOUT SIZE (W X H X D) (IN.) | 24" X 84" X 25" |
| NET WEIGHT (LBS) | 386 |

GENERAL PROPERTIES

| | |
|--------------------------------------------------|----------------------------------------------|
| PANEL READY | YES |
| DOOR SWING | LAP-LEFT, RAP-RIGHT |
| PUSH-TO-OPEN™ DOOR ASSIST | YES |
| ICEMAKER | DUAL ICEMAKER FOR STANDARD AND COCKTAIL ICE™ |
| LIGHTING | 3DLIGHTING™ |
| INTERIOR MATERIAL | STEELCOOL™ STAINLESS STEEL INTERIOR |
| FULL WIDTH SHELVES | 3 EA |
| SHELF MATERIAL | TEMPERED, METAL TRIM, SPILL-PROOF |
| FULL EXTENSION DRAWERS AT 90° DOOR OPENING ANGLE | YES |
| HIDDEN COMPARTMENT WITH FLIP-UP COVER | 1 EA |
| FREEZER DRAWER | 2 EA |
| DOOR BINS | 4 EA |
| DOOR OPEN ALARM | YES |
| SPECIAL MODES | SABBATH MODE |

CAPACITY

| | |
|-------------------------------------------|--------------|
| TOTAL UNIT GROSS CAPACITY (CU.FT.) - AHAM | 13.6 CU. FT. |
| REFRIGERATOR GROSS CAPACITY (CU.FT.) | 13.6 CU. FT. |

PERFORMANCE

| | |
|------------------------------------------|------------|
| DEDICATED EVAPORATOR & COMPRESSOR SYSTEM | YES |
| POWER FREEZE | YES |
| DEFROST PROCESS | FROST-FREE |
| PRECISE COOLING | YES |

EFFICIENCY

| | |
|---------------------------|--------------|
| ENERGY STAR QUALIFIED | YES |
| ANNUAL ENERGY CONSUMPTION | 500 KWH/YEAR |

TECHNICAL DETAILS

| | |
|-------------------------|----------------|
| CURRENT (A) | 3 |
| VOLTS (V) | 115 |
| FREQUENCY (HZ) | 60 |
| POWER CORD LENGTH (IN.) | 78 3/4" |
| PLUG TYPE | 120 V, 3 PRONG |

WARRANTY

| | |
|----------------------------------------------------------------------------|-------------------------------------------|
| LIMITED, ENTIRE APPLIANCE, PARTS AND LABOR ON ANY PART OF THE REFRIGERATOR | 2 YEAR |
| LIMITED WARRANTY FOR SEALED REFRIGERATION SYSTEM; PARTS AND LABOR | 3 RD TO 6 TH YEAR |
| LIMITED WARRANTY FOR SEALED REFRIGERATION SYSTEM; PARTS ONLY | 7 TH TO 12 TH YEAR |
| LIMITED WARRANTY FOR COMPRESSOR; PARTS ONLY | 13 TH TO 15 TH YEAR |

APPLIANCE DIMENSIONS

| | |
|----------------------------|----------------------|
| A (WIDTH) | 23 3/4" (603 MM) |
| B (WITH PANEL) | 25" (635 MM) |
| B1 (WITHOUT PANEL) | 23 13/16" (605MM) |
| C (HEIGHT) | 83 3/8" (2,118 MM) |
| D | 23 5/8" (600 MM) |
| D1 (WITH PANEL) | 24 7/8" (632 MM) |
| D2 (WITH MODERNIST HANDLE) | 26 3/4" (680 MM) |
| D3 (WITH PRO HANDLE) | 27 3/8" (696 MM) |
| E | 50 3/4" (1,289 MM) |
| F | 13 11/16" (348 MM) |
| G | 49 11/16" (1,261 MM) |

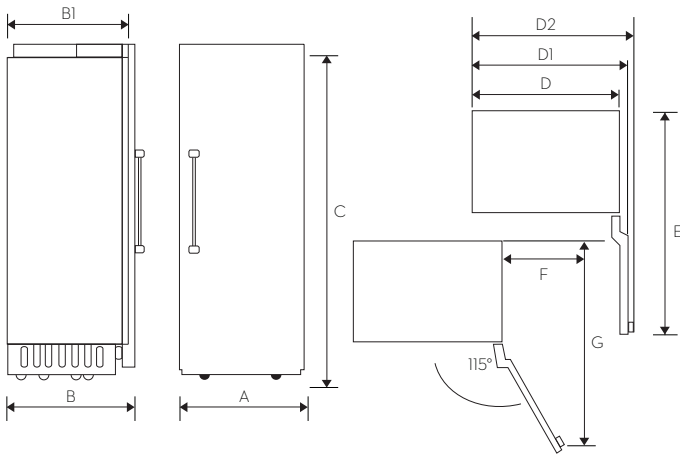

CUSTOM PANEL DIMENSIONS

| | |
|--------------|--------------------|
| A-1 (WIDTH) | 23 3/4" (603 MM) |
| A-2 (HEIGHT) | 79 7/8" (2,029 MM) |
| A-3 (DEPTH) | 3/4" (19 MM) |
| MAX WEIGHT | 110.0 LBS. (50 KG) |

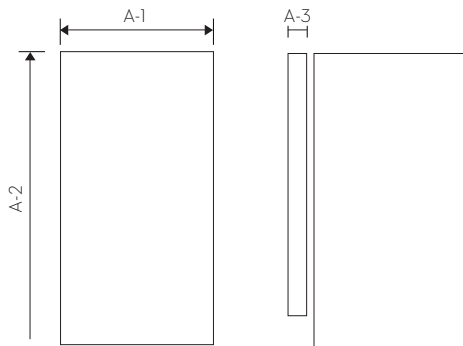

INSTALLATION CUTOUT DIMENSIONS

| | |
|------------|----------------|
| A (WIDTH) | 24" (610 MM) |
| B (DEPTH) | 25" (635 MM) |
| C (HEIGHT) | 84" (2,134 MM) |
| D | 14" (356 MM) |
| E' | 80" (2,032 MM) |

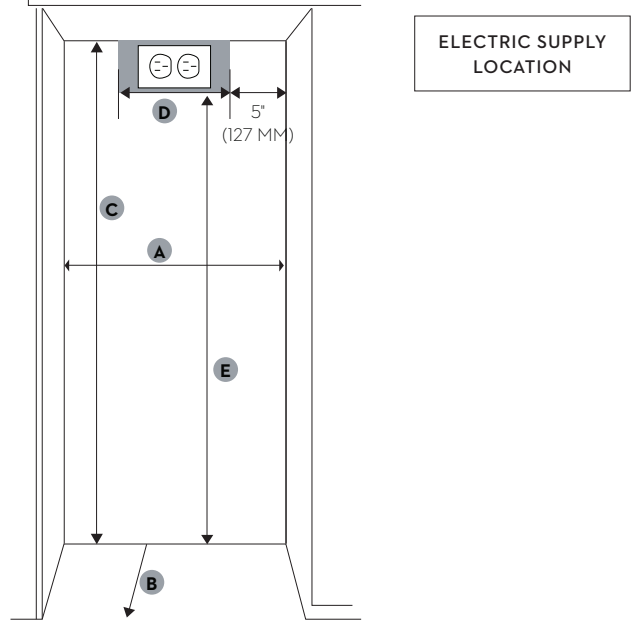

WATER SUPPLY CONNECTION REQUIREMENTS

| | |
|---|-----------------|
| A | 5 1/2" (140 MM) |
|---|-----------------|

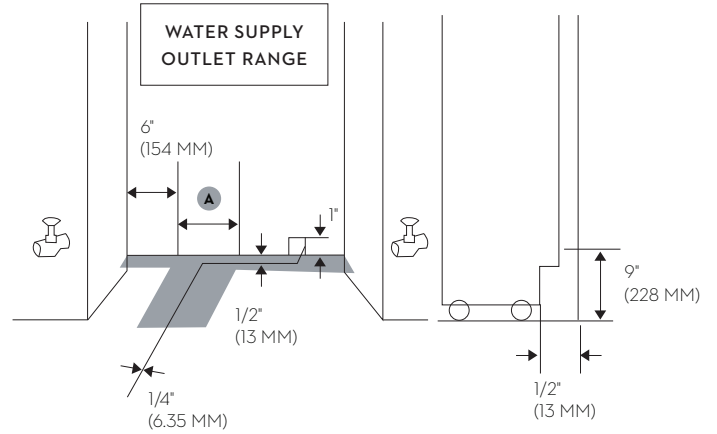

ACCESSORIES

| | |
|-----------------------------------------------------|-----------------------------------------------------|
| MODERNIST GRAPHITE STAINLESS STEEL - 24" PANEL KIT | RAC24AMRHMS (RIGHT HINGE), RAC24AMLHMS (LEFT HINGE) |
| MODERNIST SILVER STAINLESS STEEL - 24" PANEL KIT | RAC24AMRHSR (RIGHT HINGE), RAC24AMLHSR (LEFT HINGE) |
| HERITAGE PRO SILVER STAINLESS STEEL - 24" PANEL KIT | RAC24AHRHSR (RIGHT HINGE), RAC24AHLHSR (LEFT HINGE) |
| MODERNIST GRAPHITE STAINLESS STEEL - 24" KICK PLATE | RAC24TKBBMS |
| MODERNIST SILVER STAINLESS STEEL - 24" KICK PLATE | RAC24TKBBSR |
| GRAPHITE STAINLESS STEEL - MODERNIST HANDLE | RACOOMHAAMS |
| SILVER STAINLESS STEEL - MODERNIST HANDLE | RACOOMHAASR |
| SILVER STAINLESS STEEL - HERITAGE PRO HANDLE | RACOOHPAASR |
| SILVER STAINLESS STEEL - EPICURE HANDLE | ADRRZHIE |
| PAIR INSTALLATION KIT | RACOOCPAAAA |
| WATER FILTER | RACOOWFAAAA |
| DEODORIZING FILTER | RACOODFAAAA |