

## SERVICE DATA SHEET Dual Fuel Range with ES 570 Electronic Oven Control

**A NOTICE - This service data sheet is intended for use by persons having electrical and mechanical training and a level of knowledge of these subjects generally considered acceptable in the appliance repair trade. The manufacturer cannot be responsible, nor assume any liability for injury or damage of any kind arising from the use of this data sheet.**

### SAFE SERVICING PRACTICES

To avoid the possibility of personal injury and/or property damage, it is important that safe servicing practices be observed. The following are examples, but without limitation, of such practices,

1. Do not attempt a product repair if you have any doubts as to your ability to complete it in a safe and satisfactory manner.
2. Before servicing or moving an appliance, remove power cord from electric outlet, trip circuit breaker to OFF, or remove fuse and turn off gas supply.
3. Never interfere with the proper installation of any safety device.
4. USE ONLY REPLACEMENT PARTS CATALOGED FOR THIS APPLIANCE. SUBSTITUTIONS MAY DEFEAT COMPLIANCE WITH SAFETY STANDARDS SET FOR HOME APPLIANCES.
5. GROUNDING: The standard color coding for safety ground wires is GREEN OR GREEN WITH YELLOW STRIPES. Ground leads are not to be used as current carrying conductors. IT IS EXTREMELY IMPORTANT THAT THE

SERVICE TECHNICIAN REESTABLISH ALL SAFETY GROUNDS PRIOR TO COMPLETION OF SERVICE. FAILURE TO DO SO WILL CREATE A POTENTIAL HAZARD.

6. Prior to returning the product to service, ensure that:

- All electric connections are correct and secure.
- All electrical leads are properly dressed and secured away from sharp edges, high-temperature components, and moving parts.
- All non-insulated electrical terminals, connectors, heaters, etc. are adequately spaced away from all metal parts and panels.
- All safety grounds (both internal and external) are correctly and securely reassembled.
- All panels are properly and securely reassembled.

### Oven Calibration

Set the electronic oven control for normal baking at 350°F. Obtain an average oven temperature after a minimum of 5 cycles. The oven calibration can not be modified.

### Temperature Offset Adjustment

See Owner's Manual.

### Electronic oven control relay board

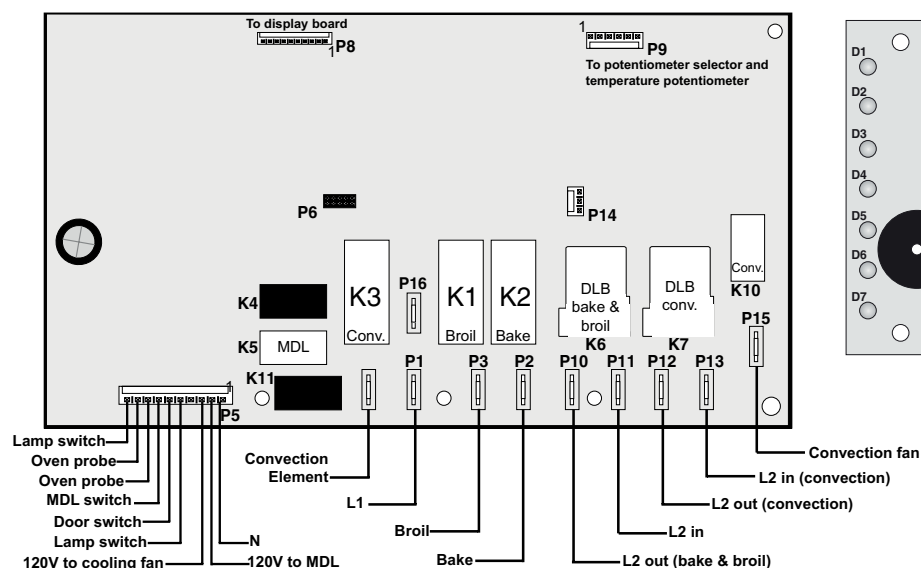

### Electronic Display Board

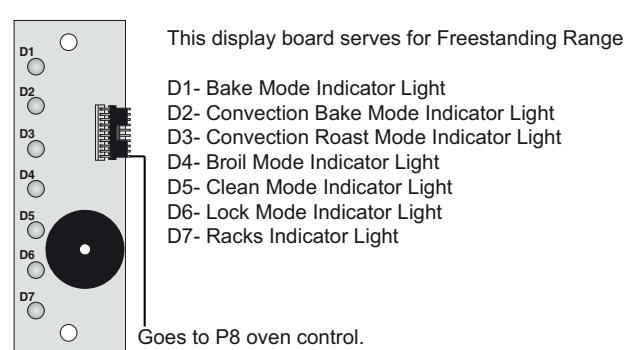

### ELECTRONIC OVEN CONTROL (EOC) FAULT CODE DESCRIPTIONS

Failure Code	Likely Failure Condition/Cause	Suggested Corrective Action																					
<table border="1" style="width: 100%;"> <tr><th colspan="7">Front Panel LED</th></tr> <tr><td>1</td><td>2</td><td>3</td><td>4</td><td>5</td><td>6</td><td>7</td></tr> <tr><td>X</td><td></td><td></td><td></td><td>X</td><td></td><td></td></tr> </table>	Front Panel LED							1	2	3	4	5	6	7	X				X			Control has sensed a potential runaway oven condition. Control may have shorted relay, RTD sensor probe may have gone bad.	Check RTD sensor probe and replace if necessary. If oven is overheating, disconnect power. If oven continues to overheat when power is reapplied, replace control board.
Front Panel LED																							
1	2	3	4	5	6	7																	
X				X																			
<table border="1" style="width: 100%;"> <tr><th colspan="7">Front Panel LED</th></tr> <tr><td>1</td><td>2</td><td>3</td><td>4</td><td>5</td><td>6</td><td>7</td></tr> <tr><td>X</td><td></td><td></td><td></td><td></td><td>X</td><td></td></tr> </table>	Front Panel LED							1	2	3	4	5	6	7	X					X		Incorrect Micro ID, controller self check failed.	Replace the control board.
Front Panel LED																							
1	2	3	4	5	6	7																	
X					X																		
<table border="1" style="width: 100%;"> <tr><th colspan="7">Front Panel LED</th></tr> <tr><td>1</td><td>2</td><td>3</td><td>4</td><td>5</td><td>6</td><td>7</td></tr> <tr><td>X</td><td></td><td></td><td></td><td></td><td></td><td>X</td></tr> </table>	Front Panel LED							1	2	3	4	5	6	7	X						X	Incorrect EEPROM Checksum, control internal checksum may have been corrupted.	Disconnect power, wait 30 seconds and reapply power. If fault returns upon power-up, replace control board.
Front Panel LED																							
1	2	3	4	5	6	7																	
X						X																	
<table border="1" style="width: 100%;"> <tr><th colspan="7">Front Panel LED</th></tr> <tr><td>1</td><td>2</td><td>3</td><td>4</td><td>5</td><td>6</td><td>7</td></tr> <tr><td></td><td></td><td>X</td><td></td><td>X</td><td></td><td></td></tr> </table>	Front Panel LED							1	2	3	4	5	6	7			X		X			Open RTD sensor probe / wiring problem.  Shorted RTD sensor probe / wiring problem.	<ul style="list-style-type: none"> <li>- Check wiring in probe circuit for possible open condition.</li> <li>- Check RTD resistance at room temperature (compare to probe resistance chart). If resistance does not match the chart, replace RTD sensor probe.</li> <li>- Let the oven cool down and restart the function.</li> <li>- If problem persist, replace control board.</li> </ul>
Front Panel LED																							
1	2	3	4	5	6	7																	
		X		X																			
<table border="1" style="width: 100%;"> <tr><th colspan="7">Front Panel LED</th></tr> <tr><td>1</td><td>2</td><td>3</td><td>4</td><td>5</td><td>6</td><td>7</td></tr> <tr><td></td><td>X</td><td></td><td></td><td></td><td>X</td><td></td></tr> </table>	Front Panel LED							1	2	3	4	5	6	7		X				X			
Front Panel LED																							
1	2	3	4	5	6	7																	
	X				X																		
<table border="1" style="width: 100%;"> <tr><th colspan="7">Front Panel LED</th></tr> <tr><td>1</td><td>2</td><td>3</td><td>4</td><td>5</td><td>6</td><td>7</td></tr> <tr><td>X</td><td>X</td><td>X</td><td></td><td></td><td></td><td></td></tr> </table>	Front Panel LED							1	2	3	4	5	6	7	X	X	X					Door motor mechanism failure.	<ul style="list-style-type: none"> <li>- Turn off power for 30 seconds, then turn on power.</li> <li>- Check wiring of lock motor, lock switch circuits.</li> <li>- Unplug the lock motor from the board and apply power (L1) directly to the lock motor. If the motor does not rotate, replace the lock motor assembly.</li> <li>- Check lock switch for proper operation (do they open and close, check with ohmmeter). The lock motor may be powered as in above step to open and close lock switch. If the lock switch is defective, replace motor lock assembly.</li> <li>- If all above steps fail to correct situation, replace the control board.</li> </ul>
Front Panel LED																							
1	2	3	4	5	6	7																	
X	X	X																					

#### LED Legend:

- 1 - Bake
- 2 - Convection Bake
- 3 - Convection Roast
- 4 - Broil
- 5 - Clean
- 6 - Lock
- 7 - Remove racks

Circuit Analysis Matrix	DLB1 L2 out P10	DLB2 L2 out P12	Bake P2	Broil P3	Conv P4	Door Motor P3	Conv. Fan P15	Door Switch P5-6 & P5-5	Cooling Fan Sp. P5-3
Bake	X	X	X	X	X		X		X
Convection Bake	X	X	X	X	X		X		X
Convection Roast	X	X	X	X	X		X		X
Broil	X			X					X
Self-Clean	X	X	X	X	X				X
Locking						X*			
Unlocking						X			
Door Open									
Door Closed								X	

Notes: X\*= Motor latch will only lock when the tack switch is closed (rack removed).  
 Relay will operate in this condition only.

**IMPORTANT**  
**DO NOT REMOVE THIS BAG**  
**OR DESTROY THE CONTENTS**  
**WIRING DIAGRAMS AND SERVICE**  
**INFORMATION ENCLOSED**  
**REPLACE CONTENTS IN BAG**

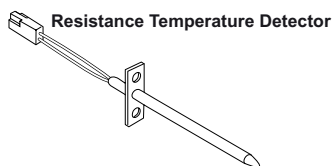

RTD SCALE	
Temperature °F (°C)	Resistance (ohms)
32 ± 1.9 (0 ± 1.0)	1000 ± 4.0
75 ± 2.5 (24 ± 1.3)	1091 ± 5.3
250 ± 4.4 (121 ± 2.4)	1453 ± 8.9
350 ± 5.4 (177 ± 3.0)	1654 ± 10.8
450 ± 6.9 (232 ± 3.8)	1852 ± 13.5
550 ± 8.2 (288 ± 4.5)	2047 ± 15.8
650 ± 9.6 (343 ± 5.3)	2237 ± 18.5
900 ± 13.6 (482 ± 7.5)	2697 ± 24.4
Probe circuit to case ground	Open circuit/infinite resistance

# General Troubleshooting Diagram

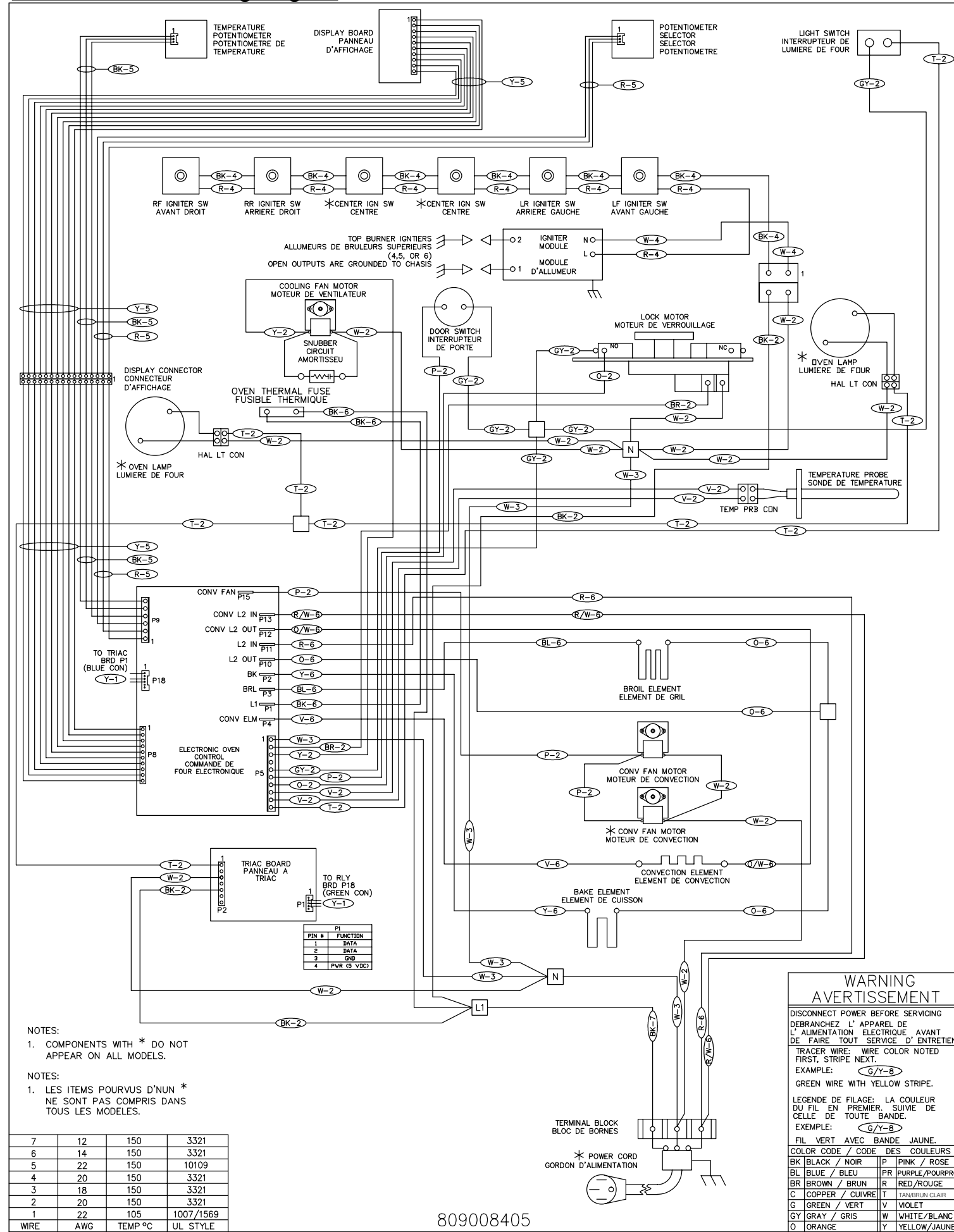

809008405

7	12	150	3321
6	14	150	3321
5	22	150	10109
4	20	150	3321
3	18	150	3321
2	20	150	3321
1	22	105	1007/1569
WIRE	AWG	TEMP °C	UL STYLE

# General Troubleshooting Schematic

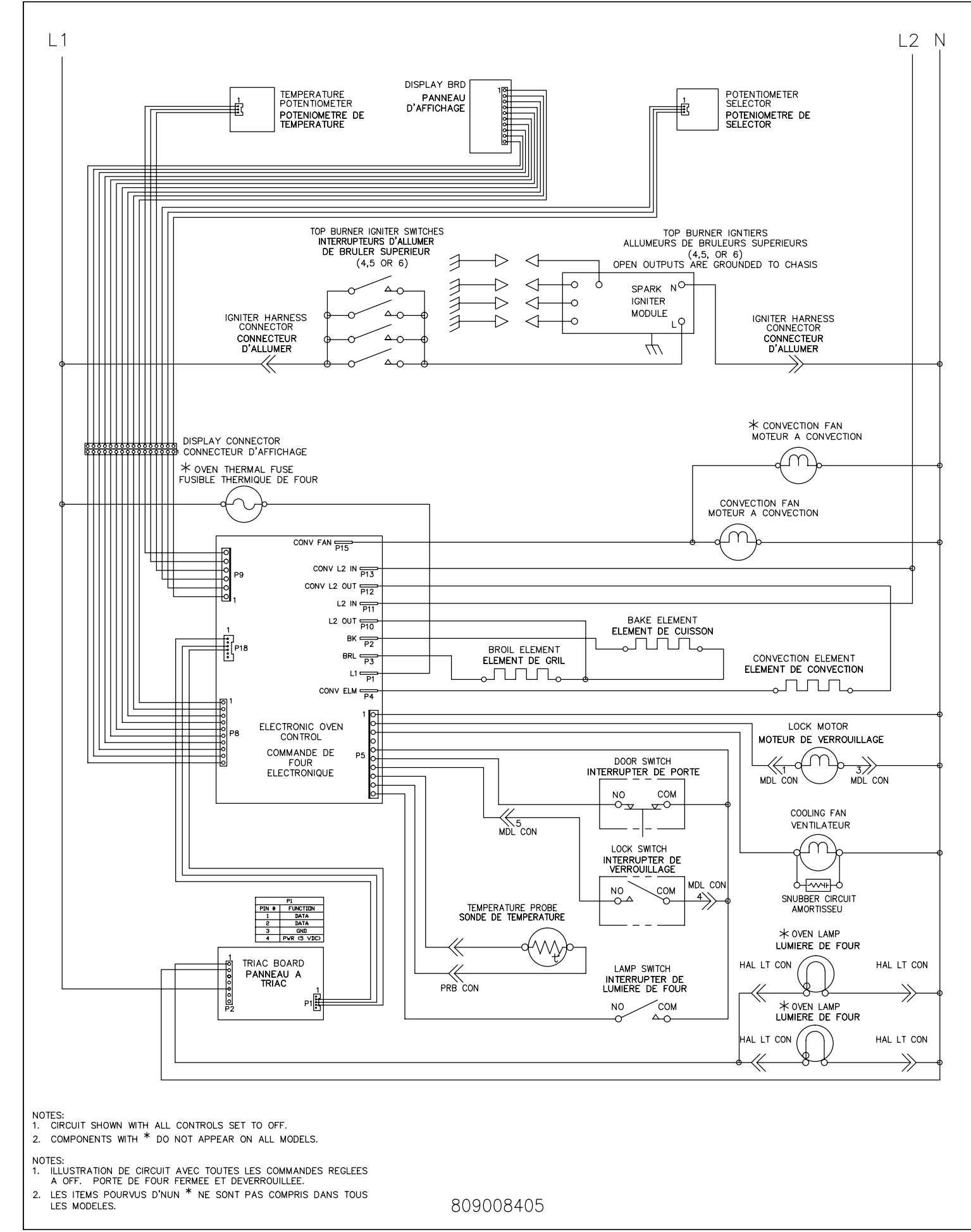

809008405