

Use & Care Guide
Refrigerator Drawers

Guia de Uso y Cuidado
Cajones de refrigerador

Guide D'utilisation et D'entretien
Tiroirs de réfrigérateur

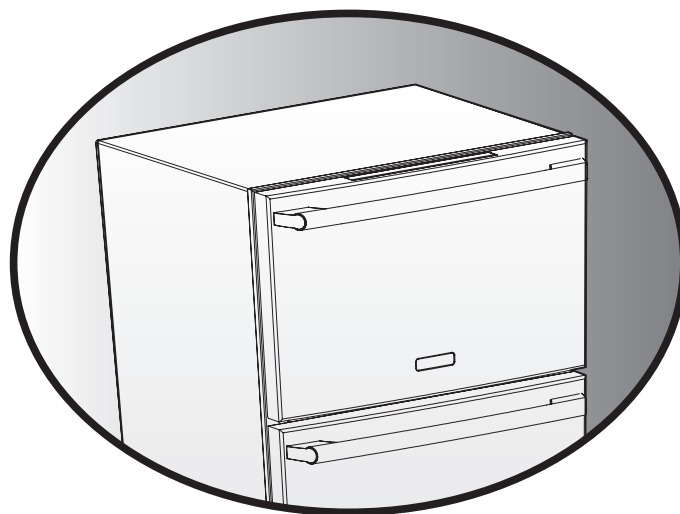

 **Electrolux**

Please Read and Save This Guide

Thank you for choosing Electrolux, the new premium brand in home appliances. This Use & Care Guide is part of our commitment to customer satisfaction and product quality throughout the service life of your new refrigerator drawers.

We view your purchase as the beginning of a relationship. To ensure our ability to continue serving you, please use this page to record key product information.

IMPORTANT

PLEASE READ all instructions completely before attempting to install or operate the unit. All refrigerator drawers require a connection to an electrical power source. Improper hook-up can result in a safety hazard and potential damage to the product or contents! Proper installation, in accordance with the manufacturer's specifications and all local codes, is the sole responsibility of the consumer. The manufacturer is not responsible for any installation expenses or damages incurred due to improper installation. If you are unsure of your ability to safely connect electric power to the unit, consult a licensed and insured professional to perform all electrical work.

Once you have your unit installed, we suggest you keep this manual in a safe place for future reference. Should any problems occur, refer to the "**Troubleshooting**" section of this manual. This information will help you quickly identify a problem and get it remedied. In the event you require assistance, please contact the dealer where you purchased your unit.

Make a Record for Quick Reference

Whenever you call to request information or service, you will need to provide your model number and serial number. You can find this information on the serial plate located on the ceiling of your unit and on the product registration card.

Product Registration Card

The package containing this manual also includes your product registration information. Warranty coverage begins at the time your Electrolux refrigerator drawers were purchased.

NOTE

Registering your product with Electrolux enhances our ability to serve you. You can register online at **www.electroluxappliances.com** or by dropping your Product Registration Card in the mail. Complete and mail the Product Registration Card as soon as possible to validate the registration date.

Please record the purchase date of your Electrolux unit and your dealer's name, address, and telephone number.

Purchase Date

Electrolux Model Number

Electrolux Serial Number

Dealer Name

Dealer Address

Dealer Telephone

Keep this manual and the sales receipt together in a safe place for future reference.

Questions?

For toll-free telephone support in the U.S. and Canada:

1-877- 4ELECTROLUX (1-877-435-3287)

For online support and Internet product information:
www.electroluxappliances.com

Table of Contents

| | |
|--|-----------|
| Finding Information | 2 |
| Please Read and Save This Guide | 2 |
| Make a Record for Quick Reference | 2 |
| Product Registration Card | 2 |
| Questions? | 2 |
| Safety | 4 |
| Important Safety Instructions | 4 |
| Safety Precautions | 4 |
| Definitions | 4 |
| General Precautions | 4 |
| Installation | 5 |
| Installing the Refrigerator Drawers | 5 |
| Site Preparation | 6 |
| Leveling the Unit | 6 |
| Start-Up and Temperature Control | 7 |
| Starting the Unit | 7 |
| Adjusting the Temperature | 7 |
| Operation | 8 |
| Description of Features | 8 |
| Alarms | 8 |
| Notifications | 8 |
| Sabbath Mode | 8 |
| Maintenance | 9 |
| Removing your Refrigerator Drawers | 9 |
| To Remove Top Drawer | 9 |
| To Remove Bottom Drawer | 9 |
| Maintaining Refrigerator Drawers | 9 |
| Exterior Cleaning for Your Stainless Steel Model | 9 |
| Interior Cleaning | 10 |
| To Replace Air Filter | 10 |
| Troubleshooting | 11 |
| Before You Call for Service | 11 |
| If Service is Required | 11 |
| Warranty Information | 12 |

Important Safety Instructions

Safety Precautions

Do not attempt to install or operate your unit until you have read the safety precautions in this manual. Safety items throughout this manual are labeled with a Danger, Warning, or Caution based on the risk type.

Definitions

 This is the safety alert symbol. It is used to alert you to potential personal injury hazards. Obey all safety messages that follow this symbol to avoid possible injury or death.

DANGER

DANGER indicates an imminently hazardous situation which, if not avoided, will result in death or serious injury.

WARNING

WARNING indicates a potentially hazardous situation which, if not avoided, could result in death or serious injury.

CAUTION

CAUTION indicates a potentially hazardous situation which, if not avoided, may result in minor or moderate injury.

IMPORTANT

Indicates installation, operation, or maintenance information which is important but not hazard-related.

General Precautions

WARNING

RISK OF CHILD ENTRAPMENT. Before you throw away your old appliance, take off the doors and leave shelves in place so that children may not easily climb inside.

WARNING

- Never attempt to repair or perform maintenance on the unit until the electricity has been disconnected.
- Altering, cutting of power cord, removal of power cord, removal of power plug, or direct wiring can cause serious injury, fire and/or loss of property and/or life and will void the warranty.
- Do not lift unit by door handle.

CAUTION

- Use care when moving the unit. Some edges are sharp and may cause personal injury. Wear gloves when moving or repositioning the unit.
- Never install the unit behind closed doors. Be sure front grille is free of obstruction. Obstructing free air flow can cause the unit to malfunction and may void the warranty.
- Allow unit temperature to stabilize for 24 hours before use.

CAUTION

- Use only genuine Electrolux replacement parts. Imitation parts can damage the unit and may void the warranty.

Installing the Refrigerator Drawers

Your Electrolux refrigerator drawers have been designed for built-in installation. When built-in, your refrigerator drawers do not require additional air space for top, sides, or rear. The front grille must **NOT** be obstructed.



NOTE

To ease unit installation and removal, it is recommended that the cabinet rough opening dimensions be increased by at least 1/4 inch over the dimensions given for your unit.



WARNING

Double drawer Refrigerator Drawers are designed to be built-in only. They can not be used for free-standing.

All screws supplied with the Anti-Tip Kit are for mounting the bracket directly to wall studs. These screws will not work if used with sheetrock (dry wall) or anything other than wall studs.

Unit Dimensions

| Width | Height | Depth |
|---------------------------------------|--------------|-------------------------------------|
| 23 ¹³ / ₁₆ inch | 34-35 inches | 26 ³ / ₄ inch |

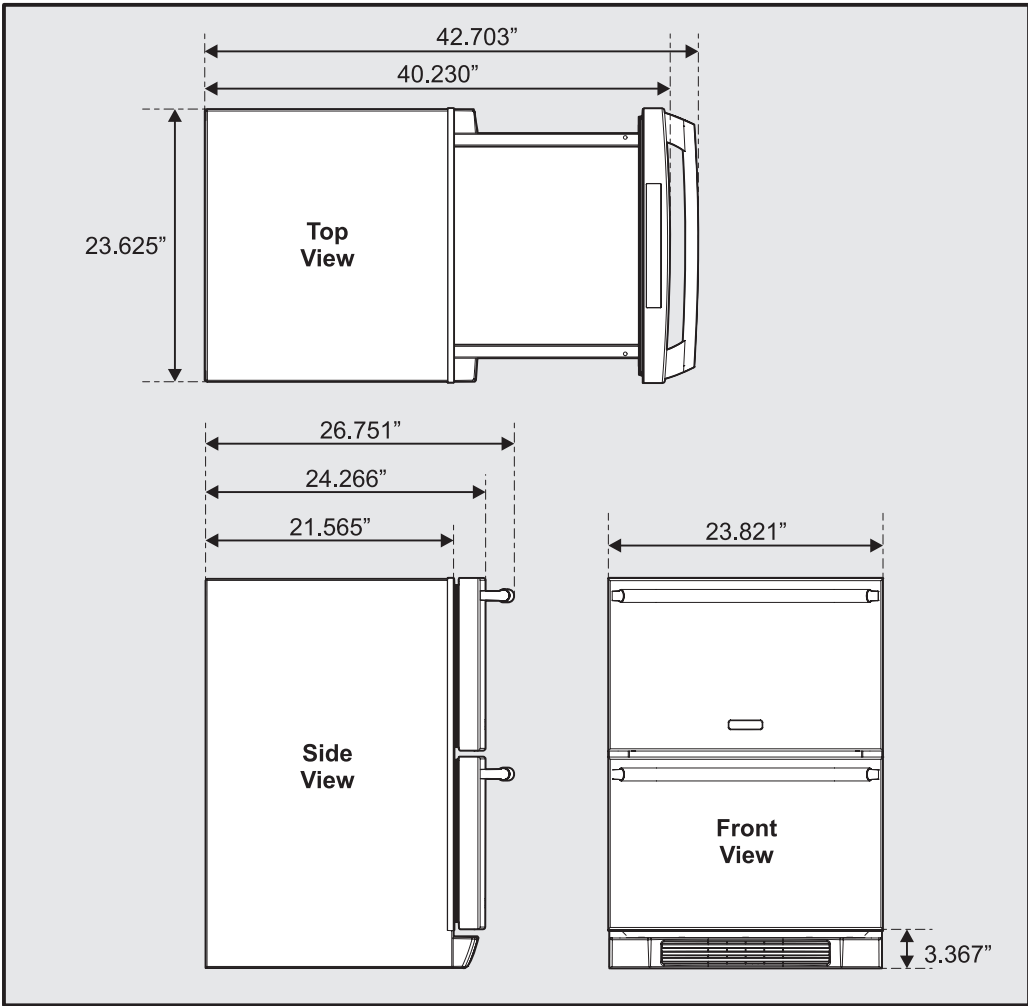

Product Dimensions

Installation

Site Preparation

- 1 Position the unit on a flat, level surface capable of supporting the entire weight of the unit. Remember the unit will be significantly heavier once it is fully loaded.
- 2 This unit requires a grounded and polarized 115 VAC, 60Hz, 15A circuit (normal household current).
- 3 Avoid connecting the unit to a Ground Fault Interruptor (GFI). GFIs are prone to nuisance tripping which will cause the unit to shut down. GFIs are generally not used on circuits which power equipment that must run unattended for long periods of time.
- 4 The unit must be installed according to your local codes and ordinances.

WARNING

ELECTROCUTION HAZARD!

Electrical Grounding Required - This appliance is equipped with a three prong (grounding) polarized plug for your protection against possible shock hazards.

- NEVER remove the round grounding prong from the plug.
- NEVER use a two-prong grounding adapter.
- NEVER use an extension cord to connect power to the unit.

Where a two-prong wall receptacle is encountered or a longer power cord is required, contact a qualified electrician to have it replaced in accordance with applicable electrical codes.

- 5 Position the unit to allow free air flow through the front grille.

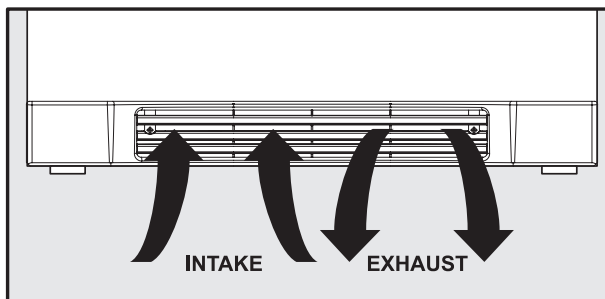

- 6 Wipe out inside of unit with a damp cloth.
- 7 Be sure to install the Anti-Tip bracket. Follow the instructions provided with the Anti-Tip bracket kit.

WARNING

The Anti-Tip Kit must be installed on this unit before it is used. Double stacking units may cause serious personal injury.

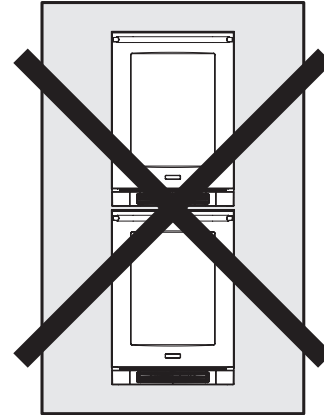

Leveling the Unit

Position the unit on a flat, level surface capable of supporting the entire weight of the unit when full.

This unit contains four (4) adjustable leveling legs. Turn the legs clockwise to raise and counterclockwise to lower.

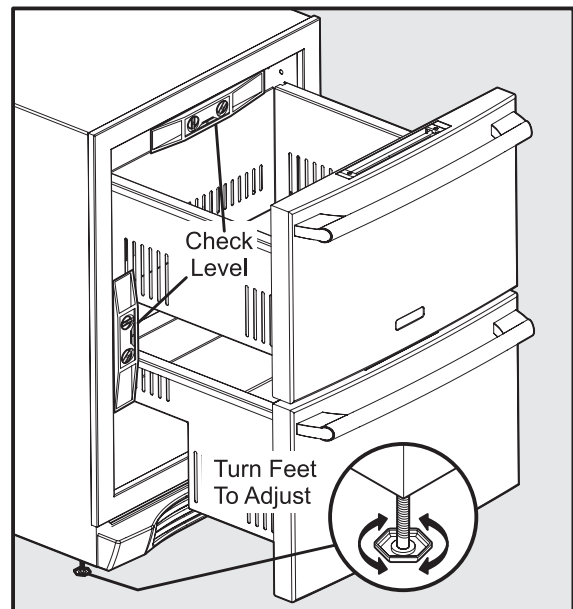

Starting the Unit

Your refrigerator drawers unit is shipped in the ON position; however, you may turn it ON or OFF by pressing and holding the ON/OFF for three (3) seconds and then releasing the key.

Adjusting the Temperature

To accurately check the temperature, insert a reliable thermometer into a plastic (non-breakable) bottle, partially filled with water. Tighten the bottle cap securely.

Place the bottle in the desired area for 24 hours. Refrain from opening the unit during the testing period. After 24 hours, check the temperature of the water.

Press and release the (+) or (-) indicator to adjust the temperature to the desired setting. The temperature display will begin to blink with the first touch and release. Adjust the temperature by touching and releasing the key. After three (3) seconds of inactivity, the display will beep to accept the new temperature.

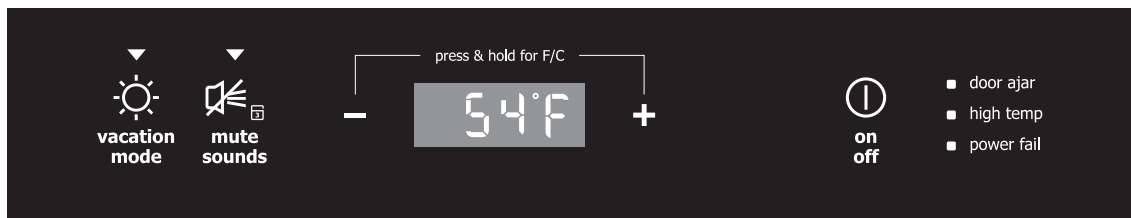
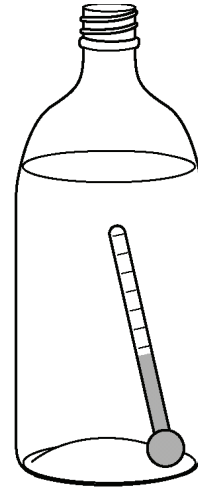

Factors that affect the internal temperatures of the cabinet include:

- 1 Temperature setting
- 2 Room temperature where installed
- 3 Number of times the door is opened and closed
- 4 Amount of time the internal light is illuminated
- 5 Installation in direct sunlight or near a heat source

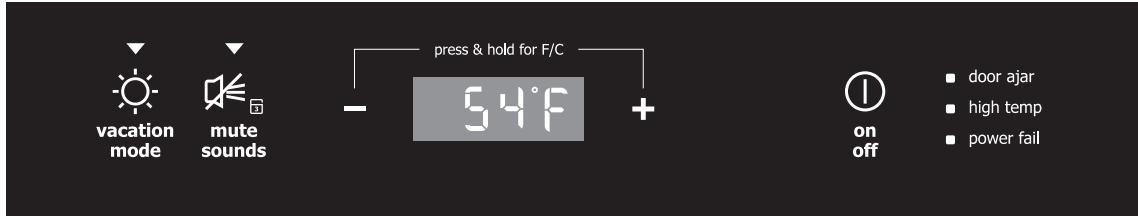

Description of Features

| | |
|-------------------------|---|
| vacation mode | Conserves energy by disabling interior lights and keypad inputs. |
| mute sounds | Tones emitted by each keypress can be turned off based on user preference. The sounds are muted when the red indicator is lit. The mute sounds key also is used to acknowledge alarm conditions, denoted by a flashing red indicator. Press and hold the mute sounds key for three (3) seconds then release to enable control lock , which prevents undesired changes to the unit settings. Temperature display will show “LOC”. |
| temperature mode | Simultaneously press and hold the (+) and (-) keys for three (3) seconds then releasing the key causes the temperature display to toggle from Fahrenheit to Celsius and back again. |
| on off | Press and hold for three (3) seconds then release the key. This allows the user to turn off the cooling system. The temperature display will display “OFF”. THIS DOES NOT REMOVE POWER FROM THE UNIT. |

Alarms

| | |
|------------------|--|
| door ajar | If the door has been left open for five (5) minutes, an audible alarm will sound and the door ajar indicator will illuminate on the right side of the display. The mute sounds indicator will blink. Pressing and releasing the mute sounds key will acknowledge the alarm and disable the audible portion. The door ajar indicator will continue to blink until the door is closed. |
| high temp | In the event of a high temperature condition, an audible alarm will sound, the temperature display will blink and display “HI”, and the high temp indicator on the right side of the display will blink. The mute sounds indicator will blink. Pressing and releasing the mute sounds key will acknowledge the alarm and disable the audible |

portion. All other modes are turned off until the alarm is acknowledged. The **high temperature** indicator and “HI” will stay illuminated until a normal safe range operating temperature has been reached, at which time the temperature display will show the actual temperature.

power fail

In the event of a power failure or initial power-up, an audible alarm will sound and the **power fail** indicator on the right side of the display will blink. The **mute sounds** indicator will blink. Pressing and releasing the **mute sounds** key will acknowledge the alarm and disable the audible portion. All other functions are disabled until the alarm is acknowledged, at which point the **power fail** indicator is turned off and the unit will resume normal operation. The **high temp** alarm may also be illuminated until a safe temperature has been reached.

Notifications

air filter

After six months of use the display will show **AF**. This is a reminder that it is time to change the air filter. The product will continue to function normally. Pressing any key will reset the reminder for 10 minutes. Once the air filter is replaced, pressing the “**On/Off**” and “-” keys for three seconds will reset the reminder for another six months.

Sabbath Mode



Sabbath mode disables portions of the unit and its controls in accordance with the weekly Sabbath and religious holidays observed within the Orthodox Jewish community.

Sabbath mode is enabled and disabled by pressing and holding the **vacation mode** key for five (5) seconds and then releasing the key. Temperature display shows “Sb” while in Sabbath mode.

The customer may open or close the door at any time without concern of directly turning on or off any lights, digital readouts, solenoids, fans, valves, compressor, icons, tones or alarms. After power failure, the unit will immediately return to Sabbath mode.

While in Sabbath mode, alarm indicators will not illuminate, nor be accompanied by audible alarms.

For further assistance, guidelines for proper usage and a complete list of models with the Sabbath feature, please visit the web at <http://www.star-k.org>.

Removing Your Refrigerator Drawers

To remove top drawer:

1. Fully extend drawer.
2. Disconnect Molex connector.
3. Remove two screws using Phillips® screwdriver.
4. Remove drawer by sliding forward 1/2" and pull up.
5. Reverse procedure to reinstall drawer.

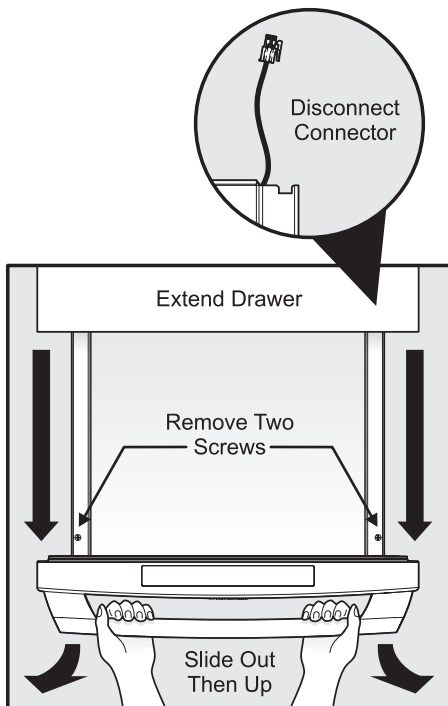

To remove bottom drawer:

1. Fully extend drawer.
2. Remove two screws using Phillips® screwdriver.
3. Remove drawer by sliding forward 1/2" and pull up.
4. Reverse procedure to reinstall drawer.

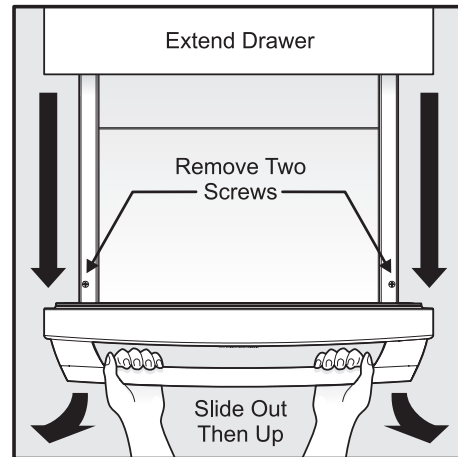

Maintaining Your Refrigerator Drawers

Periodic cleaning and proper maintenance will ensure efficiency, top performance, and long life. The maintenance intervals listed are based on normal conditions. You may want to shorten the intervals if you have pets or other special considerations.

Exterior Cleaning for Your Stainless Steel Model

- Your stainless steel model may discolor when exposed to chlorine gas, pool chemicals, salt water, or cleaners with bleach.
- Keep your stainless unit looking new by cleaning with a high quality, all-in-one stainless steel cleaner/polish on a monthly basis. Frequent cleaning will remove surface contamination that could lead to rust. Some installations will require cleaning on a weekly basis.
- DO NOT CLEAN WITH STEEL WOOL PADS.
- DO NOT USE CLEANERS THAT ARE NOT SPECIFICALLY INTENDED FOR STAINLESS STEEL (this includes glass, tile and counter cleansers).

- If any surface discolors or rusting appears, clean it quickly with Bon-Ami or Barkeepers Friend Cleanser and a non-abrasive cloth. Always clean in the direction of the grain. Always finish this process with a high quality, all-in-one stainless steel cleaner/polish to prevent further problems.
- USE OF ABRASIVE PADS SUCH AS SCOTCHBRITE WILL CAUSE THE GRAINING IN THE STAINLESS TO BECOME BLURRED.
- Rust that is allowed to linger can penetrate into the surface of the stainless steel and become impossible to remove.

CAUTION

- **Stainless steel models exposed to chlorine gas and moisture such as areas with spas or swimming pools, may have some discoloration of the stainless steel. Discoloration from chlorine gas is normal. Follow exterior cleaning instructions.**
- **NEVER USE CHLORIDE TO CLEAN STAINLESS STEEL.**

Interior Cleaning - as Required

- 1 Disconnect power to the refrigerator drawers.
- 2 Wipe down the interior with a solution of non-abrasive mild detergent and warm water.
- 3 Rinse with clear water.
- 4 Reconnect power to the unit.

To Replace Air Filter:

1. Fully extend lower drawer. Air filter is located on lower left wall of cabinet.
2. Remove old filter and replace with new filter.

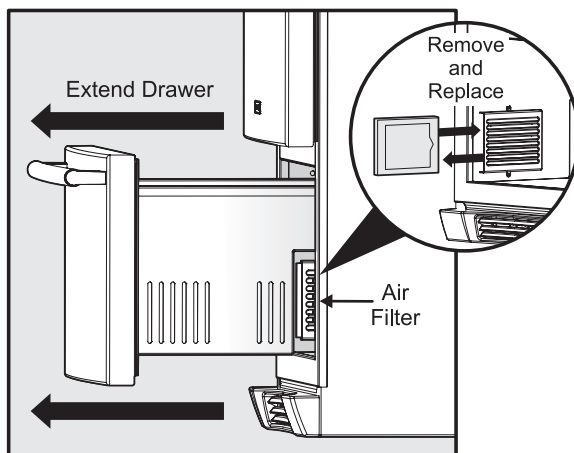

Before You Call for Service

If the unit appears to be malfunctioning, read through this manual first. If the problem persists, check the **Troubleshooting Guide** below. Locate the problem in the guide and refer to the cause and its remedy before calling for service. The problem may be something very simple that can be solved without a service call. Some remedies listed in the **Troubleshooting Guide** are very complex. Consulting or contracting a qualified service technician may be necessary.

If Service is Required

Contact the dealer where you purchased the unit if service is required. State the model and serial number and explain the problem. The model and serial number plate is located on the ceiling of your unit.

If you do not know the name of the selling dealer or a local service company, you can check online at www.electroluxappliances.com, or call **1-877-435-3287**.

WARNING

ELECTROCUTION HAZARD

NEVER attempt to repair or perform maintenance on the unit until the main electrical power has been disconnected.

| Problem | Possible Cause | Remedy |
|---|--|---|
| Unit not cold enough | <ul style="list-style-type: none"> Control set too warm Airflow to front grille blocked Door gasket not sealing properly. | <ul style="list-style-type: none"> Adjust temperature colder. See “Adjusting the Temperature” in the “Start-Up and Temperature Control” section. Allow 24 hours for temperature to stabilize. Airflow must not be obstructed to front grille. See “Installation” Section. Adjust door gasket. |
| Unit too cold | <ul style="list-style-type: none"> Control set too cold | <ul style="list-style-type: none"> Adjust temperature warmer. See “Adjusting the Temperature” in the “Start-Up and Temperature Control” section. Allow 24 hours for temperature to stabilize. |
| No interior light | <ul style="list-style-type: none"> Failed LED assembly | <ul style="list-style-type: none"> Contact a qualified Electrolux Service Technician. |
| Light will not go out when door is closed | <ul style="list-style-type: none"> Door switch not making contact | <ul style="list-style-type: none"> Check for proper door alignment. |

Major Appliance Warranty Information

Your appliance is covered by a one year limited warranty. For one year from your original date of purchase, Electrolux will repair or replace any parts of this appliance that prove to be defective in materials or workmanship when such appliance is installed, used, and maintained in accordance with the provided instructions. In addition, the cabinet liner and sealed refrigeration system (compressor, condenser, evaporator, dryer or tubing) of your appliance is covered by a two through five year limited warranty. During the 2nd through 5th years from your original date of purchase, Electrolux will repair or replace any parts in the cabinet liner and sealed refrigeration system which prove to be defective in materials or workmanship when such appliance is installed, used, and maintained in accordance with the provided instructions.

Exclusions

This warranty does not cover the following:

1. Products with original serial numbers that have been removed, altered or cannot be readily determined.
2. Product that has been transferred from its original owner to another party or removed outside the USA or Canada.
3. Rust on the interior or exterior of the unit.
4. Products purchased "as-is" are not covered by this warranty.
5. Food loss due to any refrigerator or freezer failures.
6. Products used in a commercial setting.
7. Service calls which do not involve malfunction or defects in materials or workmanship, or for appliances not in ordinary household use or used other than in accordance with the provided instructions.
8. Service calls to correct the installation of your appliance or to instruct you how to use your appliance.
9. Expenses for making the appliance accessible for servicing, such as removal of trim, cupboards, shelves, etc., which are not a part of the appliance when it is shipped from the factory.
10. Service calls to repair or replace appliance light bulbs, air filters, water filters, other consumables, or knobs, handles, or other cosmetic parts.
11. Pickup and delivery costs; your appliance is designed to be repaired in the home.
12. Surcharges including, but not limited to, any after hour, weekend, or holiday service calls, tolls, ferry trip charges, or mileage expense for service calls to remote areas, including the state of Alaska.
13. Damages to the finish of appliance or home incurred during transportation or installation, including but not limited to floors, cabinets, walls, etc.
14. Damages caused by: services performed by unauthorized service companies; use of parts other than genuine Electrolux parts or parts obtained from persons other than authorized service companies; or external causes such as abuse, misuse, inadequate power supply, accidents, fires, or acts of God.

DISCLAIMER OF IMPLIED WARRANTIES; LIMITATION OF REMEDIES

CUSTOMER'S SOLE AND EXCLUSIVE REMEDY UNDER THIS LIMITED WARRANTY SHALL BE REPAIR OR REPLACEMENT AS PROVIDED HEREIN. **CLAIMS BASED ON IMPLIED WARRANTIES, INCLUDING WARRANTIES OF MERCHANTABILITY OR FITNESS FOR A PARTICULAR PURPOSE, ARE LIMITED TO ONE YEAR OR THE SHORTEST PERIOD ALLOWED BY LAW, BUT NOT LESS THAN ONE YEAR.** ELECTROLUX SHALL NOT BE LIABLE FOR CONSEQUENTIAL OR INCIDENTAL DAMAGES SUCH AS PROPERTY DAMAGE AND INCIDENTAL EXPENSES RESULTING FROM ANY BREACH OF THIS WRITTEN LIMITED WARRANTY OR ANY IMPLIED WARRANTY. SOME STATES AND PROVINCES DO NOT ALLOW THE EXCLUSION OR LIMITATION OF INCIDENTAL OR CONSEQUENTIAL DAMAGES, OR LIMITATIONS ON THE DURATION OF IMPLIED WARRANTIES, SO THESE LIMITATIONS OR EXCLUSIONS MAY NOT APPLY TO YOU. THIS WRITTEN WARRANTY GIVES YOU SPECIFIC LEGAL RIGHTS. YOU MAY ALSO HAVE OTHER RIGHTS THAT VARY FROM STATE TO STATE.

If You Need Service

Keep your receipt, delivery slip, or some other appropriate payment record to establish the warranty period should service be required. If service is performed, it is in your best interest to obtain and keep all receipts. Service under this warranty must be obtained by contacting Electrolux at the addresses or phone numbers below.

This warranty only applies in the USA, Puerto Rico and Canada. In the USA and Puerto Rico, your appliance is warranted by Electrolux Major Appliances North America, a division of Electrolux Home Products, Inc. In Canada, your appliance is warranted by Electrolux Canada Corp. Electrolux authorizes no person to change or add to any obligations under this warranty. Obligations for service and parts under this warranty must be performed by Electrolux or an authorized service company. Product features or specifications as described or illustrated are subject to change without notice.

USA

1-877-435-3287

Electrolux Major Appliances North America
P.O. Box 212378
Augusta, GA 30907

Canada

1-800-265-8352

Electrolux Canada Corp.
5855 Terry Fox Way
Mississauga, Ontario, Canada L5V 3E4

 **Electrolux**

