



LEONE ISLAND

ELICA PRO SERIES



LED lamps



New commands

Designed to be suspended above a kitchen island, Leone's crisp lines, beveled rim and gleaming stainless steel deliver professional cooking with a sense of style. Give your kitchen a splash of Italian design with a chimney style island hood that has the extra depth and power required to support professional ranges and cooktops.

Available in 36" and 42" widths, Leone Island comes equipped with an extra powerful 1200 CFM internal blower and backlit hidden metallic in/out knobs, which operate the 4 speed blower and LED lighting. In addition, its professional stainless steel angled baffle filters provide an easy maintenance and help to have a cleaner kitchen.

Dimensions | Models

36" W x 27" D x 12 3/4" H | ELI136S1
Leone 30" Island

42" W x 27" D x 12 3/4" H | ELI142S1
Leone 36" Island



HUSH



LED LIGHT



PROFESSIONAL PERFORMANCE



HEAT GUARD

FEATURES

Size (in) & Type	36" or 42" wide Island Chimney
Finish	Stainless Steel
Controls	IN/OUT Backlit Knob
Illumination	4 LED 7.5 watts LED light, replaceable lamps (1 intensity)
Installation Type	Ducted Only
Blower Type	Speed 1, 375 CFMs Speed 2, 640 CFMs Speed 3, 940 CFMs Speed 4, 1200 CFMs
Filter Type	2, Dishwasher-Safe, Professional Stainless Steel, Angled Baffle Filters
Noise (sones):	Min: 3.21, Max: 7.7 Sones
Telescopic Chimney Extension	For heights 8'-0" - 10'-0" (ducted)
Duct Transition	8" Round with Back Draft Damper (Top Only)
Electrical	120 Volts, 60 Hertz

Line Drawing

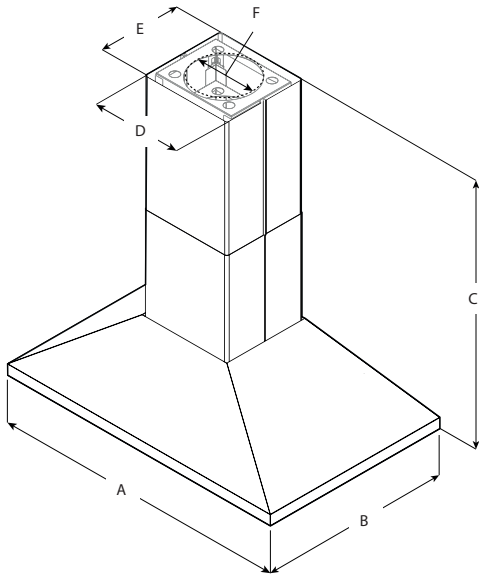

PLUS



HUSH SYSTEM
An exclusive sound deadening technology that effectively reduces sound levels by over 35%, compared to typical range hoods.



LED LIGHT
LED lighting is undoubtedly the smartest solution in terms of energy saving. Expected life time of over 20.000 hours, represents the most remarkable advantage of LED light bulbs.



PROFESSIONAL PERFORMANCE
Special features and very high performances for models with aspiration capacity between 600 and 1200 CFM's, and noise level between 65 and 75 db(A) at maximum speed. The ideal complement of PRO ranges.



HEAT GUARD
A safety feature that protects the hood and cabinetry from excessive heat, by sensing extreme temperatures (>158 degrees) and will automatically adjust the blower speed to HIGH. Blower speed will automatically adjust back once temperatures drop to a safe level.

	Models	
	ELI136S1	ELI142S1
A	36" (91.4 cm)	42" (106.7 cm)
B	27" (68.6 cm)	
C	Max: 46 9/16" (118.3 cm) Min: 37 1/2" (95.3 cm)	
D	13 3/16" (33.2 cm)	
E	12" (30.5 cm)	
F	8" (20.3 cm)	

Accessories

Optional Long Chimney Extension
CODE: KITO2785 / (30", 36")