



ICONIC *Series*

Designer hoods that make a statement in your kitchen

 elica
aria nuova

HAIKU

ENDLESS DESIGN POSSIBILITIES



MINIMALIST DESIGN AND MAXIMUM PERFORMANCE

Essential lines and innovative materials are the distinguishing traits of Haiku. Its unique design enhances any space without sacrificing powerful extraction of 600 CFM.

The name takes its inspiration from a traditional Japanese form of poetry characterized by an essential style of writing with great richness of meaning. Indeed, the new Elica extractor system is the culmination of the desire to simplify design in the pursuit of purity, while simultaneously creating the perfect harmony between functional concepts.

UNIQUE MATERIALS

Haiku is available in three finishes:

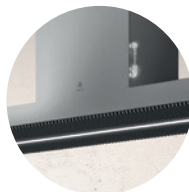

STAINLESS STEEL

Material par excellence for this category of products. Traditional with a professional appeal of the product.



ULTRA CLEAR BLACK TEMPERED GLASS

A glass with a very high strength and low iron content, which enhances its transparency properties.



BRIGHT WHITE KRION®

The composition – two-thirds natural minerals and a small percentage of resins – embedded with anti-bacterial properties and easy maintenance due to the super low porosity.

BRIGHT WHITE KRION®



100% RECYCLABLE

White KRION® is a new generation solid surface, a material that is warm to the touch, similar to natural stone. Also, it is ecological since it can be 100% recycled. It is composed of two-thirds of natural minerals and a small percentage of high-strength resins.

ANTIBACTERIAL

White KRION® has **antibacterial properties** related to the demonstrated photocatalytic capacity of the material: the KRION® surface, which prevents the bacteria formation. Also, its **hardness, strength and durability** makes possible to have a reduced maintenance, as well as easy repair and cleaning due to the super low porosity.

SOPHISTICATED BLACK IRON GRATES

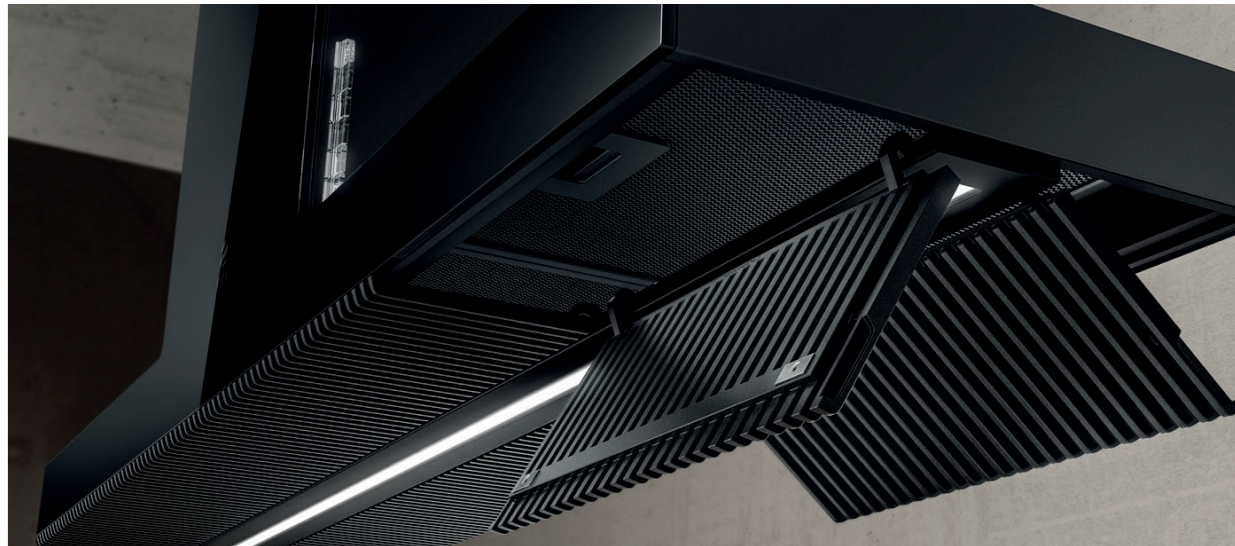

SOPHISTICATED BLACK IRON GRATES FINISH HAIKU WITH UNIQUELY UNIFORMED DESIGN

Haiku's unique style is enhanced by the black iron grates attached to the casing by **means of magnets** mounted on the hood, which gives the product solidity and professionalism and creates a double barrier for filtering fats.

To remove the grids, just tilt them 45° and then unfasten them from the locking system that prevents their release at any other inclination. Once removed, it is possible to easily extract the grease filter and wash it in the dishwasher.

Haiku can easily be converted from Duct-Out to recycling version thanks to an odor filter accessory which guarantees the elimination of unwanted odors in the kitchen.

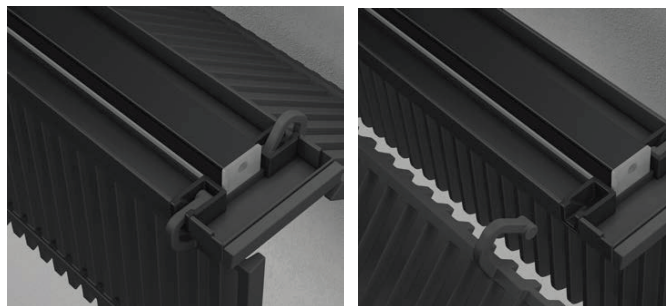

EASY TO CLEAN

Unlike all other T-Shape hoods, Haiku features no discontinuity between the body of the hood and the chimney.

The monolithic front of the hood is completely linear, making Haiku especially easy to clean.

MAINTENANCE

USER INTERFACE



CONTROLS

Back-lit and transparent controls emerge from the side of the product to ensure maximum ease of use and leave the front surface uncluttered.



LIGHTNING

Provided by a powerful, highly effective STRIP LED that runs the entire length of the hood, ensuring a uniform distribution of light (strip LED 1x7 W - natural light 3500°K).



It features a noise reduction system that achieves superbly quiet operation at all speeds thanks to the reduction of vortices and peak noise levels.

DEEP SILENCE

HAIKU WALL MOUNT



THE FIRST WALL-MOUNTED HOOD WITH ADJUSTABLE DEPTH

Elica is the first on the market to have created the innovative **SHIFT 3238 SYSTEM**, which allows millimetric adjustment of the depth of the product from 12.5" to 15", guaranteeing perfect alignment of the hood with the front edge of the cabinets.

AVAILABLE SIZES

STAINLESS STEEL

12.5", 24" 36", 48"

EHK613SS, EHK624SS,
EHK636SS, EHK648SS

ULTRA CLEAR
BLACK TEMPERED GLASS

36" EHK636BL

BRIGHT WHITE KRION®

36" EHK636WH

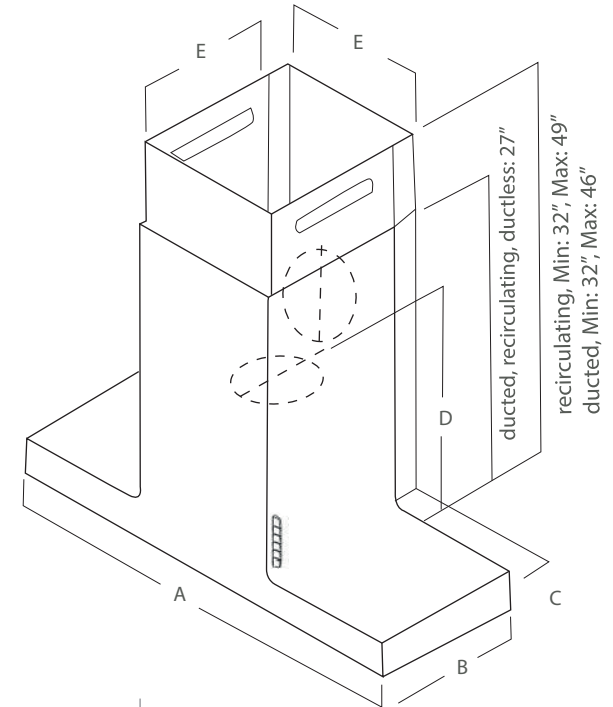

A	12.5" 24" 36" 48"
B	12 1/2"
C	Min: 0", Max: 2 3/25"
D	19"
E	12"

*Adjustable depth is only available for Wall Mount version

HAIKU

ISLAND

MINIMALIST STYLE AND PURENESS OF FORM

Haiku is designed to blend naturally with the kitchen space. The absence of discontinuity between the body and the chimney of the hood make Haiku a monolithic, tactile element, with no seams or joints on the front.



AVAILABLE SIZES

STAINLESS STEEL

12.5", 48", 70"

EHI613SS, EHI648BL,
EHI670SS

ULTRA CLEAR
BLACK TEMPERED GLASS

48" EHI648BL

BRIGHT WHITE KRION®

48" EHI648WH

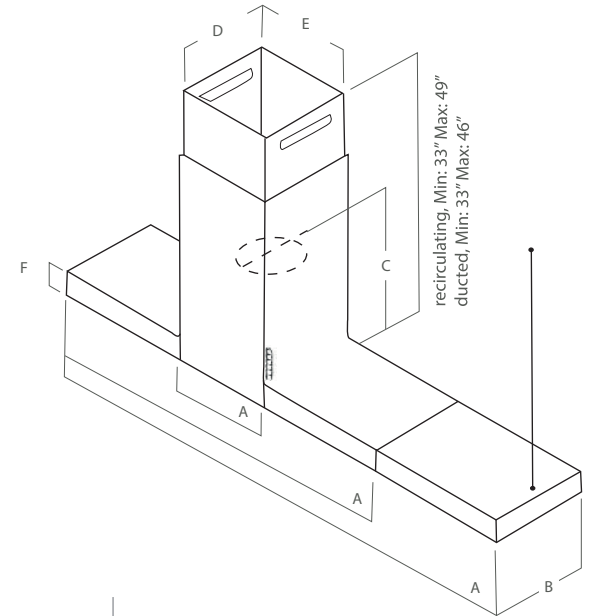

A	12.5" 48" 70"
B	13"
C	19"
D	11 13/20"
E	12"
F	3 7/50"

ILLUSION

BLENDS IN LIKE A TRUE ILLUSION



FIRST **PANEL READY** CEILING HOOD IN THE MARKET

Illusion hood guarantees an integrated look in your kitchen, perfectly matching the ceiling texture of your living space. Also naturally saves valuable kitchen space and frees the area of inconvenient obstructions, cleverly hiding a powerful extraction system that guarantees always clean air in the living space.



FINISHES

Illusion is available in two finishes:



PANEL READY DRY WALL & STAINLESS STEEL FRAME

The stainless steel frame and plasterboard panel is customizable with the texture of the ceiling.

*Note: use fireproof gypsum board panels suitable for the operating conditions in terms of temperature (at least 176°F) and humidity (at least 93%) reached during application.

The total weight of the gypsum board should not exceed 8.8 lbs.



WHITE PANEL AND FRAME

Made of a metal sheet with white coat painted and a metal frame white painted.

POWERFUL AND SILENT

Equipped with perimeter aspiration, Illusion has a powerful extraction of 600 CFM and only 2.1 sones.

It is available in Duct Out version with Recirculating Kit sold separately. (KIT0167875)

LIGHTNING



STRIP LED: DIM LIGHT & TUNE WHITE

The lighting is entrusted to two LED strips: the dimmer allows you to change the intensity of the light, while the innovative Tune-White system guarantees the best shade of white by adjusting the light temperature.

Use the remote control to adjust the lightning to create your desired atmosphere as well as the speed of your hood.



- Sensor activation
- Blower speed
- Ambient light
- Light

EASY INSTALLATION

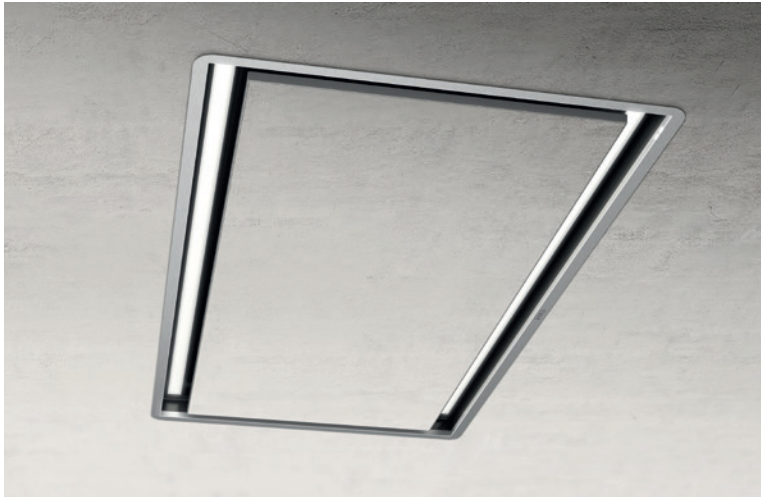

Thanks to a patented facilitated installation system, the hood can be fixed extremely easily.

Assembly takes place in just a few steps: automatic locking on the false ceiling, adhesion of the frame to the carved edge of the plasterboard and adjustment on four points of each corner of the hood.

HILIGHT

FOR ARCHITECTURE AND DESIGN LOVERS



HILIGHT FITS PERFECTLY INTO ANY ARCHITECTURAL KITCHEN PROJECT

Hilight is the ideal ally to create an inspiring atmosphere. It fits into a contemporary- modern style space with a perfectly flush installation, leaving the space above the hob completely free and without view obstructions.



FINISHES

Hilight is available in two finishes:

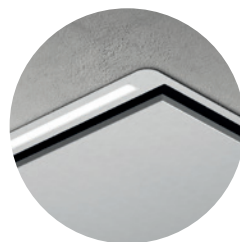

STAINLESS STEEL & STAINLESS STEEL FRAME

Elegant and simple, both the panel and the frame are stainless steel and offer a modern style duo.

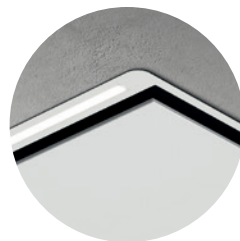

WHITE GLASS PANEL & WHITE FRAME

Stylish and trendy, the panel is made out of white glass and the frame is a made of metal sheet with a white coat paint.

POWERFUL AND SILENT

Equipped with perimeter aspiration, Hilight has a powerful extraction of 600 CFM and only 2.1 sones.

It is available in Duct Out version with Recirculating Kit sold separately. (KIT0167875)

LIGHTNING



STRIP LED: DIM LIGHT & TUNE WHITE

The lighting is entrusted to two LED strips: the dimmer allows you to change the intensity of the light, while the innovative Tune-White system guarantees the best shade of white by adjusting the light temperature.

Use the remote control to adjust the lightning to create your desired atmosphere as well as the speed of your hood.



- Sensor activation
- Blower speed
- Ambient light
- Light



EASY INSTALLATION



Thanks to a patented facilitated installation system, the hood can be fixed extremely easily.

Assembly takes place in just a few steps: automatic locking on the false ceiling, adhesion of the frame to the carved edge of the plasterboard and adjustment on four points of each corner of the hood.

CEILING HOODS LINE DRAWINGS

HIGHLIGHT DIMENSIONS

EHL640WH | EHL640SS

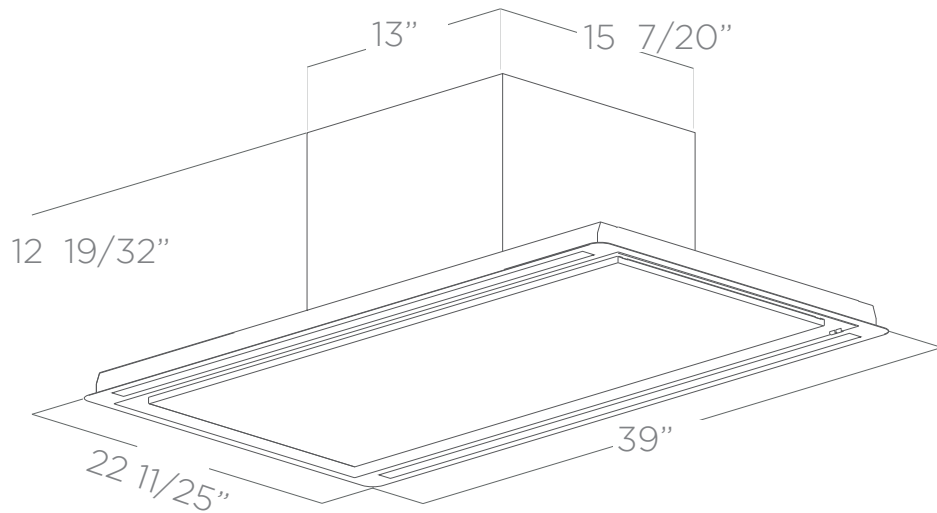

FALSE CEILING CUT: $21 \frac{21}{32}$ " X $38 \frac{1}{2}$ "

ILLUSION DIMENSIONS

EIL640WH | EIL640DW

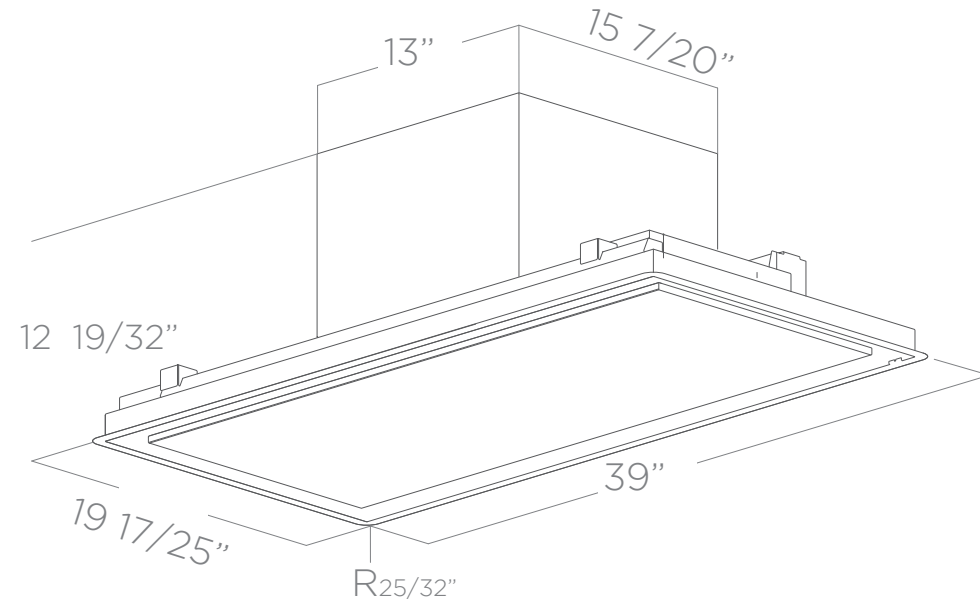

FALSE CEILING CUT: $18 \frac{57}{64}$ " X $38 \frac{37}{64}$ "



EASY

Many are stunned by Easy 's pendent light appearance, touch control, LED lighting and perimeter aspiration are pleased to find its decorative qualities by a high functioning range hood hidden within.

Easy is available in two finishes:



**STAINLESS
STEEL**

EES320SS



**WHITE
MATTE**

EES320WT

Easy has touch controls to choose between the 4-speed blower levels with a performance of 355 CFM. It comes with dishwasher safe aluminium mesh filters and revolution filter. It's 3 LED lights will make the your kitchen a unique, pleasant enviornment.

Easy can be converted to wall mount with the optional wall mounting bracket kit sold separatley. (KIT0121394)

Also, if you have a significant high distance between your countertop and your ceiling, there is a high ceiling extension kit (6'10" - 23'5") (KIT01921).

ELICA 'S EXCLUSIVE PLUS FEATURES



TOUCH
CONTROL



PERIMETER
ASPIRATION



REVOLUTION
FILTER



LONG LIFE
FILTER



LED LIGHT



EASY
INSTALLATION



AMBIENT LIGHT

Timer, clean
filter indicator



SIENA

Siena installs into the ceiling and is discreetly flush mounted, which allows the cabinetry and outdoors to take center stage. However, when it's time to cook, Siena will easily do the job.

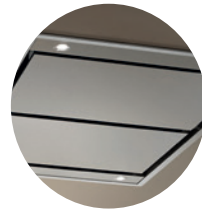

STAINLESS STEEL

ESNX4352
+ motor
ESNBLK26



SIENA'S REMOTE CONTROL

With a powerful 600 CFM and in-line blower (sold separately), which can be installed in the attic for added silence and peacefulness.

The 43" x 27" size provides excellent capture of fumes and the Perimeter Aspiration Technology increases suction and makes it a highly effective hood despite its out-of-sight location.

Both the bright LED lighting and the 4 speed blower are conveniently operated by an ergonomic remote control.

Siena comes in duct out installation mode.

ELICA'S EXCLUSIVE PLUS FEATURES



TOP PERFORMANCE



BLOWER KIT



REMOTE CONTROL



PERIMETER ASPIRATION



AMBIENT LIGHT



LED LIGHT

Timer, clean filter indicator



GLIDE

The ultra-thin Glide brings a sleek understated look to modern kitchens that desire minimalism. The crescent shape profile is uncommon and attractive, while the retractable, curved glass visor helps capture cooking vapors, and empowers the user to operate the blower and lights without reaching for the controls.



**STAINLESS STEEL &
CLEAR GLASS**

30" EGL430S1
36" EGL436S1

Sleek design, chrome-plated details, reliability, power. The curved glass surface of Glide allows to extract vapors easily and, when not in use, it can slide in to give more space to the kitchen or to use its controls.

Glide also has a 400 CFM blower of 4 speeds, backlit electronic push buttons, LED lighting and long life dishwasher-safe, stainless steel mesh filters.

Glide can be either duct out or recirculating mode by adding a recirculating kit (sold separately). (FO0539)

ELICA'S EXCLUSIVE PLUS FEATURES



LONG LIFE
FILTER



LED LIGHT



DIM LIGHT

Stand by mode, timer, change filter alarm



CHROME

An island hood with an elegant vertical style, Chrome's design is simple yet sophisticated, with four separate panels of polished stainless steel, forming the sides of the chimney, which convey strength and timeless grace.



STAINLESS STEEL

ECH623S1



JET BLACK REMOTE CONTROL

Chrome with the EDS3 (Elica deep silence) technology, delivers the golden pleasures of silence. With only 4.8 sonas at top speed, the kitchen is truly a peaceful place to pass the time...in perfect silence.

The powerful 600 CFM blower and LED lighting are operated by a touch sensitive steel rod control, aptly named the Magic Wand. A gentle touch of the finger to the rod is all it takes, or operate it from anywhere in the room with the beautifully crafted Jet black remote control (sold separately).

ELICA'S EXCLUSIVE PLUS FEATURES



TOP PERFORMANCE

P



ELICA DEEP SILENCE



LED LIGHT



HEAT GUARD

Stand by mode, clean filter indicator, change filter alarm, visual speed indicator

ELICA'S EXCLUSIVE PLUS FEATURES



UNIQUE MATERIALS

Products designed with special materials and finishes with great aesthetic impact but also with practical and durable characteristics, perfect for the kitchen.



TOUCH CONTROL

Multi function electronic touch control will illuminate soft blue when activated.



LED LIGHT

LED lighting is undoubtedly the smartest solution in terms of energy saving. Expected life time of over 20.000 hours, represents the most remarkable advantage of LED light bulbs.



HEAT GUARD

Safety feature: when sensing extreme temperatures, will automatically adjust the blower speed to high and then adjust back once temperature drops to safe level.



TOTAL INTEGRATION

These products have been designed to be seamlessly integrated into the kitchen whilst maintaining harmony with the surroundings.



REMOTE CONTROL

Elica's ADA compliant Remote Control, provides added convenience to the typical user, as well as, full function access for those with limited mobility.



DIM LIGHT

The Dimmer allows you to adjust the brightness of the light as you wish. With Elica, lighting is customized in a discreet, personal and practical way, in order to contribute in creating the perfect kitchen atmosphere.



REVOLUTION FILTER

Achieve filtering thresholds of 82% against market average of 60%.



DEEP SILENCE

Haiku is equipped with Deep Silence noise abatement system that allows you to achieve high silence at all speeds thanks to the elimination of vortices and noise peaks.



ELICA DEEP SILENCE

An exclusive sound deadening technology that utilizes a patented filter design, which substantially eliminates air turbulence and ultimately reduce sound levels.



TUNE WHITE

The ability to choose the preferred shade of white always creates the right atmosphere. The Kelvin degrees regulation starts from a very warm tone, 2400°K, up to a cold colour, 5000°K



LONG LIFE FILTER

A filter that can be regenerated and keeps characteristics for up to 3 years, avoiding unnecessary replacements and waste. It has level efficiency of 60%.



EASY INSTALLATION

Installation can be done in total safety in just a few steps, safeguarding the look of the product and the space in which it is positioned.



PERIMETER ASPIRATION

The technology draws air through a narrowed channel around a face plate, which increases suction, without increasing blower speed or energy consumption.



AMBIENT LIGHT

Ambient light not only lights the cooktop, but the entire kitchen space and so the hood is transformed: from a kitchen appliance to a true lighting element.



BLOWER KIT

Offers installation flexibility that will accommodate most construction requirements plus provided options related to ventilation power and sound generation.



TOP PERFORMANCE

High fume capturing capacity for models with aspiration capacity between 600 and 1200 CFM's with low noise levels (1.2-1.7 sones at working speed).

REALIZED BY
ELICAMEX MARKETING TEAM

This catalogue is the property of Elica spa. All rights reserved.
Any reproduction, even partial, is strictly prohibited.

Typographic printing does not always reproduce original colors and materials faithfully.

Elica reserves the right to make changes to the data and details of the products in this catalogue, even without notice.

JUNE 2020



3 YEARS
FULL
WARRANTY

EARN A 3RD YEAR OF FULL FACTORY WARRANTY

COVERING ALL PARTS PLUS
IN-HOME LABOR.

FOR U.S & CANADA USERS ONLY

By registering any Elica product from Iconic series on the elica.com site, it will be possible to extend the warranty free of charge up to three years. No additional costs for parts or in-home labor. Only at certain Elica authorized service centers. For valid warranty extension, register within 3 months from purchase.

<https://elica.com/US-en/register-product>



VISIT elica.com

