



- CRS
CFM
REDUCTION
- TOUCH
CONTROL
- HUSH
SYSTEM
- TOP
PERFORMANCE
- LED LIGHT
- CLEAN FILTER
ALARM
- REPLACE FILTER
ALARM

ELICA'S EXCLUSIVE
PLUS FEATURES

The rounded front, beautifully sloping angles and stainless steel finish of Pilato make a striking visual statement. Available in 30" or 36" widths, Pilato features include a powerful 600 CFM blower, 2 LED lights, dishwasher safe stainless steel microhole filters and multi-function electronic controls with LCD display that deliver convenience and safety.

Designed for standard ducted installation, Pilato can also be installed as a recirculating system using the Recirculating Kit, available as an accessory.

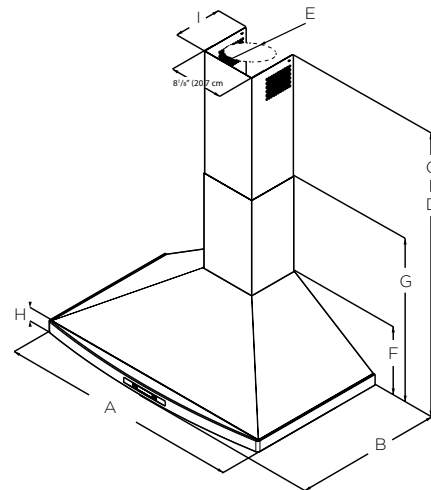

	EPL630S2	EPL636S2
A	30" (76.2 cm)	36" (91.2cm)
B	21 1/2" (54.7 cm)	
C*	Min: 28 7/8 (73.3cm) Max: 42 1/16(106.9cm)	
D**	Min: 28 5/8" (72 cm) Max: 38"(96.6 cm)	
E	6" (15.9 cm)	
F	10" (25.4cm)	
G	24 1/8" (61cm)	
H	1 1/2" (4cm)	
I	7 1/4" (18.4cm)	
J	8 1/8" (20.7cm)	

* Ductless (Recirculating) version ** Ducted version



SPECIFICATIONS



	30" UNIT	36" UNIT
Model:	EPL630S2	EPL636S2
Dimensions:	30" W x 21 1/2" D x 24 1/8" H	36" W x 21 1/2" D x 24 1/8" H
Blower Type(internal):	600 CFM (4-speed)	
Blower Performance:		
Speed 1	160 CFM	
Speed 2	280 CFM	
Speed 3	470 CFM	
Speed 4	600 CFM	
Noise (sones): Working Speed	Min: 2.03, Max: 8	
Finish:	Stainless Steel	
Controls:	Stainless Steel with black glass	
Illumination:	Touch Control 3 Speeds + Booster	
Filter Type:	2 LED Lights, 2.5 w	
Electrical:	120V - 60 Hz 450 Watt at 3.7 Amp	
Installation Type:	Ducted or Recirculating with Recirculating Kit (sold separately)	
Duct Transition:	Top Round 6"	
KITS:		
Recirculating Kit (Contains 6" deflector & 2 Round Carbon Filters)	KIT02766 / KIT02721	
Chimney Extension Kit:	KIT02762	
CONSUMABLE PARTS:		
Charcoal Filter Replacement:	MAT0100812	
Grease Filter Replacement:	GF09PB	
*Consumable parts are sold in units of one (1). Order accordingly		
INSTALL HEIGHTS:		
Ranger Hood:	Ducted - Min: 7'0", Max: 9'2" Recirculating - Min: 7'5", Max: 9'6"	
Ranger Hood with extension duct covers:	Ducted - Min: 8'8", Max: 12'4" Recirculating - Min: 9'0", Max: 12'8"	

PLUS FEATURES

- CFM REDUCTION - CFM Reduction System (CRS)**, is an exclusive feature to Elica hoods, which enables the user directly in the glass touch control the maximum blower CFM, to meet local code requirements.
- DIM LIGHT** - The Dimmer allows you to adjust the brightness of the light as you wish. With Elica, lighting is customized in a discreet, personal and practical way, in order to contribute in creating the perfect kitchen atmosphere.
- TOUCH CONTROLS** - Enjoy effortless cooking and fully control each cooking zone with the tip of a single finger.
- HUSH SYSTEM** - An exclusive sound deadening technology that effectively reduces sound levels by over 35%.

*The product images shown are for illustration purposes only and may not be an exact representation of the product.

- TOP PERFORMANCE** - Excellent performance for models equipped with this plus. High fume capturing capacity with an average aspiration range of 600 CFM* and a noise level between 60-65 db (A) at maximum speed (reference point varies based on the hood category).
- LED LIGHT** - LED lighting is undoubtedly the smartest solution in terms of energy saving. Expected life time of over 20.000 hours, represents the most remarkable advantage of LED light bulbs.
- CLEAN FILTER ALARM** - When activated, your hood will emit a "beep" signal to let you know when is time to clean your filters. For some models, an intermittent light will remain active until cleaning filter action is completed. See instructions manual to activate feature.
- REPLACE FILTER ALARM**- When activated, your hood will emit a "beep" signal let you know when is time to replace the carbon filters. See instructions manual to activate feature.