

COMFORT SERIES
TOBLINO 24



3X LAYER
MESH FILTER



LED LIGHT

ELICA'S EXCLUSIVE
 PLUS FEATURES

Toblino, with its super sleek hood design that's only 2" high is the perfect complement for modern kitchen designs that feature futuristic sharp architectural lines. Available in 24" width, Toblino features backlit push button controls, LED lights and 3 speed blower.

Toblino features a telescopic chimney for up to 8'5" ceilings. Designed for standard ducted installation, Toblino can also be installed as recirculating system using the kit available as an accessory.

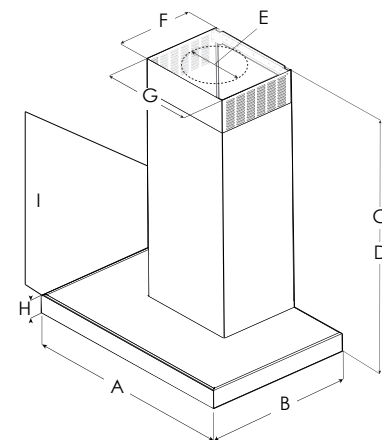

	ETB424SS
A	24" (60.9cm)
B	19 ¹ / ₁₆ " (50 cm)
C*	Max: 35" (89 cm) Min: 20 ³ / ₄ " (52.7 cm)
D**	Max: 31 ³ / ₁₆ " (79.2 cm) Min: 20 ¹ / ₂ " (52.2 cm)
E	6" (15.24 cm)
F	10 ³ / ₄ " (27 cm)
G	13 ¹ / ₃₂ " (33 cm)
H	1 ⁵ / ₈ " (4 cm)
I	15 ⁵ / ₁₆ " (38.9 cm)

* Ductless (Recirculating) version
 ** Ducted version



≥24"



≥30"

MOUNTING
 HEIGHT
 RANGE

SPECIFICATIONS

Width:	24" Unit
Model:	ETB424SS
Dimensions:	24" W x 19 11/16" D x Min: 21 1/2" Max: 35" H
Blower Type(internal):**	400 CFM(3-speed)
Noise (sones): **	5.9 Sones
Finish:	Stainless Steel
Controls:	Backlit Electronic Push Buttons
Illumination:	2 LED Lights, 2.1 W, 4000 K
Grease Filter:	(2)Dishwasher-Safe, Anodized Aluminum Mesh Filter
Duct Transition:	6" Round with BackDraft Damper (top only)
Installation Type:	Ducted or Recirculating (Kit sold separately)
Telescopic Chimney:	Can reach ceiling heights 6'11" - 8'7" (ducted), 7'0" - 8'11" (recirculating)
Electrical:	120V - 60 Hz, 260 W
KITS:	
Long Chimney Extension Kit:	KIT02785 (Ducted: 12'1" - Recirculating: 12'5") KIT01935 (Ducted 7'5" - 10'5", 7'9" - Recirculating: 10'9")
Recirculating Kit:	KIT0102875 (contains 6" deflector, 3 flat carbon filters and clips)
CFM Reduction Kit:	KIT0175561 (achieves 280 CFM)
Upgrade filter Kit:	GF04YB (Contains 1 filter)
INSTALL HEIGHTS:	
Standar duct cover:	Ducted: Min: 6'11", Max 8'7" Recirculating: Min: 7'0", Max: 8'11"
WARRANTY:***	Two (2) Years Parts & In-Home Labor. Earn an additional One (1) Year of Parts & In-Home Labor by registering on elica.com.



3X LAYER GREASE FILTER - Elica aluminum mesh filters are a step above competition, featuring triple layered, anodized aluminum that is woven into a highly dense mesh. The thick mesh captures more grease, anodization helps resist staining and provides durability to repeated cleanings in the dishwasher.



LED LIGHT - LED lighting is undoubtedly the smartest solution in terms of energy saving. Expected life is over 20,000 hours, and should last the full life of the hood.

HVI Certified Ratings	High Speed	Working Speed	Duct Size
CFM	340	100	6" (Vertical)
Sones	7	0.5	6" (Vertical)

* The product images shown are for illustration purposes only and may not be an exact representation of the product.

** Blower performance indicates the performance of the blower by itself. Performance claims are not HVI certified but were established in accordance with HVI Standardized test procedure. For Certified Ratings, please refer to HVI Certified Product Directory. Electric Ratings are declared according to UL.

*** For valid warranty extension, register within 3 months from purchase. For USA & Canada Users Only.