



3X LAYER
MESH FILTER



LED LIGHT



CRS
CFM REDUCTION

ELICA'S EXCLUSIVE
PLUS FEATURES

Toblino, with its super sleek hood design that's only 2" high is the perfect complement for modern kitchen designs that feature futuristic sharp architectural lines.

Available in 30" or 36" widths, Toblino features multiple backlight color touch controls that illuminate in elegant white, green, blue or red that operate the LED lights and 4 speed blower. Multiple clicking sound options are also available.

Designed for standard ducted installation, Toblino can also be installed as recirculating system using the kit available as an accessory.

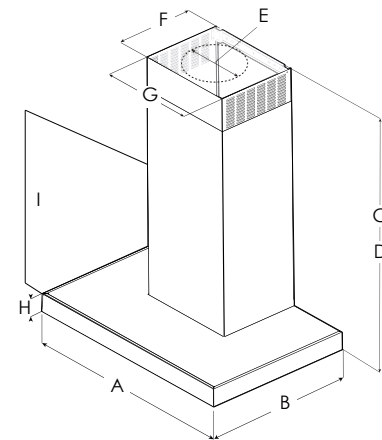

	ETB430S3	ETB436S3
A	30" (76.2 cm)	36" (91.4 cm)
B	19 1/16" (50 cm)	
C*	Max: 35" (89 cm) Min: 20 3/4" (52.7 cm)	
D**	Max: 31 3/16" (79.2 cm) Min: 20 1/2" (52.2 cm)	
E	6" (15.24 cm)	
F	10 3/4" (27 cm)	
G	13" (33 cm)	
H	1 5/8" (4 cm)	
I	15 5/16" (38.9 cm)	

* Ductless (Recirculating) version
** Ducted version



≥24"



≥30"

MOUNTING
HEIGHT
RANGE

COMFORT SERIES
TOBLINO



SPECIFICATIONS

Width:	30" Unit	36" Unit
Model:	ETB430S3	ETB436S3
Dimensions:	30"W x 19 11/16 "D x 20 1/2"H	36"W x 19 11/16 "D x 20 1/2"H
Blower Type (internal):**	400 CFM(4-speed)	
Blower Performance:**	5.9 Sones	
Noise (sones):	Stainless Steel	
Finish:	Electronic Touch Controls with Adjustable Color Backlight	
Controls:	2 LED, 2.1 W, 3000 K	
Illumination:	Dishwasher-Safe, Anodized Aluminum Mesh Filter	
Grease Filter:	2 for 30" & 3 for 36"	
Duct Transition:	6" Round with BackDraft Damper (top only)	
Installation Type:	Ducted or recirculating	
Telescopic Chimney:	Can reach ceiling heights 6'11" - 8'7" (ducted), 7'0" - 8'11" (recirculating)	
Electrical:	120V - 60 Hz, 265 W	
KITS:	KIT02785 (Ducted: 12'1" - Recirculating 12' 5")	
Long Chimney Extension Kit:	KIT0102875 (contains 6" deflector, 3 flat carbon filters and clips)	
Recirculating Kit:	GF04YB (Contains 1 filter)	
Upgrade filter Kit:		
WARRANTY:***	Two (2) Years Parts & In-Home Labor. Earn an additional One (1) Year of Parts & In-Home Labor by registering on elica.com.	

PLUS FEATURES



3X LAYER GREASE FILTER - Elica aluminum mesh filters are a step above competition, featuring triple layered, anodized aluminum that is woven into a highly dense mesh. The thick mesh captures more grease, anodization helps resist staining and provides durability to repeated cleanings in the dishwasher.



LED LIGHT - LED lighting is undoubtedly the smartest solution in terms of energy saving. Expected life is over 20,000 hours, and should last the full life of the hood.



CFM REDUCTION - CFM Reduction System (CRS), is an exclusive feature to Elica hoods, which enables the user to reduce the maximum blower CFM, to meet local code requirements.

HVI Certified Ratings	High Speed	Working Speed	Duct Size
CFM	340	100	6" (Vertical)
Sones	7	0.5	6" (Vertical)

* The product images shown are for illustration purposes only and may not be an exact representation of the product.

** Blower performance indicates the performance of the blower by itself. Performance claims are not HVI certified but were established in accordance with HVI Standardized test procedure. For Certified Ratings, please refer to HVI Certified Product Directory. Electric Ratings are declared according to UL.

*** For valid warranty extension, register within 3 months from purchase. For USA & Canada Users Only.