



VARNA WALL



LED light with dimmer

The clean lines, beautiful sloping angles and stainless steel finish of Varna make a striking visual statement. Available in 30" or 36" width, Varna features include a powerful 600 CFM blower, LED dimmable lighting, dishwasher-safe stainless steel microhole filter, and easy to use glass capacitive touch controls that deliver convenience and safety.

Designed for standard ducted installation, Varna can also be installed with recirculating system using the kit available as an accessory.

TECHNE SERIES

Dimensions | Models

30"W x 19 11/16"D x 10 1/4"H | EVR630S2
VARNA 30"

36"W x 19 11/16"D x 10 1/4"H | EVR636S2
VARNA 36"



FEATURES

Size (in) & Type	36" or 36" wide Wall Chimney
Finish	Stainless Steel + Black Glass
Controls	Touch Control 3S + Booster
Illumination	2 Premium LED Dimmable Lights
Installation Type	Ducted, Recirculating Kit sold separately
Blower Type	Speed 1, 160 CFMs Speed 2, 280 CFMs Speed 3, 470 CFMs Speed 4, 600 CFMs
Filter Type	Dishwasher- Safe, Stainless Steel Microhole Filter
Noise (sones):	Min: 1.93, Max: 6 Sones
Duct Transition	Round 6"/150cms
Electrical	120 Volts, 60 Hertz, 265 Watts, 2.2 Amps

Line Drawing

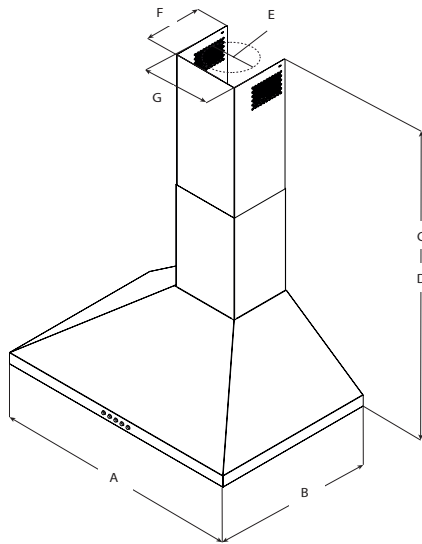

	Models	
	EVR630S2	EVR636S2
A	30" (76.2 cm)	36" (91.4 cm)
B	19 1/16" (50 cm)	
C*	Max: 42 1/8" (107 cm) Min: 28 3/16" (72 cm)	
D**	Max: 38 3/16" (97 cm) Min: 28 3/16" (72 cm)	
E	6" (15.24 cm)	
F	7 3/16" (18.3 cm)	
G	8 3/16" (20.8 cm)	

* Ductless (Recirculating) version
** Ducted version

Accessories

- Optional Recirculating Kit**
CODE: KITO2766 / (30", 36")
- Optional Long Chimney Extension**
CODE: KITO2762 / (30", 36")

PLUS



TOP PERFORMANCE

Excellent performance for models equipped with this plus. High fume capturing capacity with an average aspiration range of 600 CFM's. With a noise level between 60-65 db(A) at maximum speed (reference point varies based on the hood category).



AMBIENT LIGHT

Elica studies on hood lighting leaves no stone unturned. Here we have thought about products not only able to light the cooktop, but the entire kitchen space. And so the hood is transformed: from a kitchen appliance to a true lighting element. Considering the design of Elica hoods, it is not hard to imagine how this option is unique, and represents one extraordinary point of strength for us.



LED LIGHT

LED lighting is undoubtedly the smartest solution in terms of energy saving. Expected life time of over 20,000 hours, represents the most remarkable advantage of LED light bulbs.



HUSH SYSTEM

An exclusive sound deadening technology that effectively reduces sound levels by over 35%, compared to typical range hoods.



DIM-LIGHT

The Dimmer allows you to adjust the brightness of the light as you wish. With Elica, lighting is customized in a discreet, personal and practical way, in order to contribute in creating the perfect kitchen atmosphere.



CFM REDUCTION

CFM Reduction System (CRS), is an exclusive feature to Elica hoods, which enables the installer to reduce the maximum blower CFM, to meet local code requirements.