



EASY Island



LED ambient light



Perimeter aspiration

Easy's brilliant glossy finish reflects the world around it like a kaleidoscope, and provides a powerful visual impact, while the modern, clean-lined definition makes it easily adaptable to a variety of styles and environments.

Many are misled by Easy's pendent light appearance, LED lighting and perimeter aspiration, but they are also pleased to find beyond its decorative qualities a highly functioning range hood hidden within.

ICONIC SERIES

Dimensions | Models

19 3/4" W x 19 3/4" D x 16 7/8" H | EES320SS
EASY 20"



TOP PERFORMANCE



PERIMETER ASPIRATION



EASY INSTALLATION



LED LIGHT



AMBIENT LIGHT



LOGLIFE FILTER

FEATURES

Size (in) & Type	20" wide hanging installation
Finish	Stainless steel
Controls	Touch Control 3S+ Booster
Illumination	3x2 LED 5W 4000K
Installation Type	Recirculating
Blower Type	4 Speed Motor Speed 1: 102 CFM Speed 2: 162 CFM Speed 3: 240 CFM Speed 4: 313 CFM
Noise (sones):	Min: 1.65, Max: 5 Sones
Filter Type	Aluminum Mesh Filter + Perimeter Aspiration
Electrical	220V – 60 Hz

Line Drawing

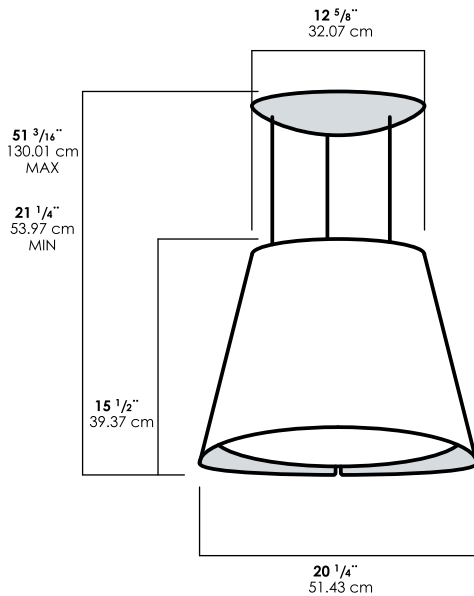

PLUS

**TOP PERFORMANCE**

Excellent performance for models equipped with this plus. High fume capturing capacity with an average aspiration range of 600 CFM's. With a noise level between 60-65 db(A) at maximum speed (reference point varies based on the hood category).

**PERIMETER ASPIRATION**

First developed by Elica, this technology literally turned the market 45 degrees and opened the door to hoods that could be mounted on the wall like picture frames. The technology draws air through a narrowed channel around a faceplate, which increases suction, without increasing blower speed or energy consumption.

**AMBIENT LIGHT**

Elica studies on hood lighting leaves no stone unturned. Here we have thought about products not only able to light the cooktop, but the entire kitchen space. And so the hood is transformed: from a kitchen appliance to a true lighting element. Considering the design of Elica hoods, it is not hard to imagine how this option is unique, and represents one extraordinary point of strength for us.

**LED LIGHT**

LED lighting is undoubtedly the smartest solution in terms of energy saving. Expected life time of over 20,000 hours, represents the most remarkable advantage of LED light bulbs.

**EASY INSTALLATION**

The Easy Installation plus has been designed to make the installation of a hood easier; in case the hood is wall mounted, through an adjustment of the appliance alignment between the cabinets; if the hood is built-in mounted, through well explained.

**LONG LIFE FILTER**

In this case, the plus is a very efficient, one-of-a-kind odour filter, capable of regenerating itself and of lasting up to 3 years, while standard filters have an average life between 3 to 6 months. To maintain these characteristics, the filter only requires simple maintenance: wash every 2 or 3 months with hot water and mild soap (also in the dishwasher at 65