

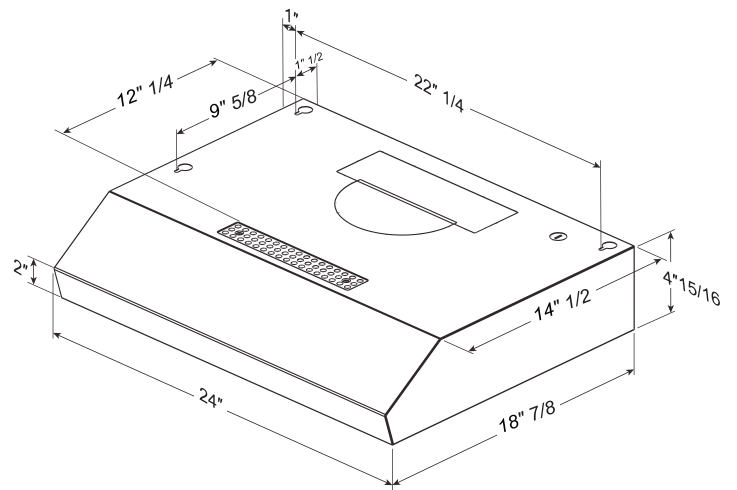

ELICA'S EXCLUSIVE
 PLUS FEATURES

GUBBIO is the perfect option for a functional kitchen with reduced spaces. With a powerful aspiration of 250 CFM, three speeds and LED lights, this undercabinet Hood is ideal for builder projects.



MOUNTING
 HEIGHT
 RANGE

≥24"

≥30"



SPECIFICATIONS

Width:	24" UNIT
Model:	EGB224SS
Dimensions:	24 (61 cm) x 18 7/8" (48 cm) x 4 15/16" (12.5 cm)
Blower Type(internal):	Internal S15, 3 speeds
Blower Performance:	250 CFM
Speed 1	100
Speed 2	160
Speed 3	250 CFM
Speed 4	-
Noise (sones): Woking Speed	2.5 WS Horizontal 2.5 WS Vertical 3 1/4" x 10" 3 WS Vertical 7"
Finish:	Stainless Steel 2B P4
Controls:	Slider control
Illumination:	2 LED, 2.1 Watts
Filter Type:	2 Aluminum mesh
Duct transition:	Top or rear Rectangular duct 3 1/4" x 10"
Installation Type:	Ducted
Electrical:	120 V, 60 Hz
KITS:	
Recirculating kit	KITO2726
No return valve 7"	KITO2723
Duct Transition 7"	KITO2722
CONSUMABLE PARTS:	
Replacement Light Bulb (1)	LMP0117673

*The product images shown are for illustration purposes only and may not be an exact representation of the product.

PLUS FEATURES



LED LIGHT - LED lighting is undoubtedly the smartest solution in terms of energy saving. Expected life time of over 20,000 hours, represents the most remarkable advantage of LED light bulbs.