

COMFORT SERIES

# NEMI BLACK & WHITE



3X LAYER  
MESH FILTER



LED LIGHT

ELICA'S EXCLUSIVE  
PLUS FEATURES

Nemi sports a slender 5" height and soft curves, designed to modernize and perfectly fit kitchens where space is premium. Nemi features a 3-speed, 280 CFM internal blower, which provides sufficient ventilating power for most kitchens. The **Stainless Steel Push Button Controls** allow for easy adjustment of blower speeds and **2 LED Lamps**. A single dishwasher-safe anodized aluminum mesh filter is easy to clean. Nemi is designed for standard ducted installation, and can be installed as a recirculating system, using the Recirculating Kit, available as an accessory.

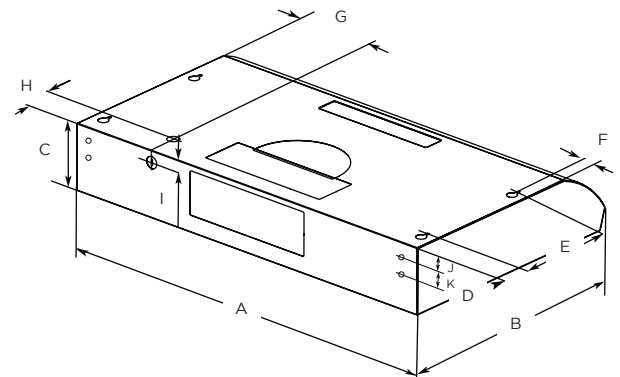

	Models	
	ENM230B1	ENM230W1
A	30" (76.2 cm)	
B	18 5/8" (47.3 cm)	
C	4 15/16" (12.5 cm)	
D	1 1/2" (3.8 cm)	
E	9" (22.9 cm)	
F	1" (2.5 cm)	
G	6 9/16" (16.7 cm)	
H	1 15/16" (5 cm)	
I	7/8" (2.2 cm)	
J	1 1/16" (2.6 cm)	
K	1 7/16" (3.6 cm)	

## SPECIFICATIONS



	30" UNIT	
Model:	ENM230B1	ENM230W1
Dimensions:	30"W x 18 3/4"D x 5"H	
Blower Type(internal):	280 CFM (3-speed)	
Blower Performance:		
Speed 1	110 CFMs	
Speed 2	200 CFMs	
Speed 3	280 CFMs	
Noise (sones):	Min: 1.5, Max: 4.7 Sones	
Woking Speed		
Finish:	Black	White
Controls:	Stainless Steel Push Button Controls	
Illumination:	2 LED Lights	
Filter Type:	1 Dishwasher- Safe, Aluminum Mesh Grease Filter	
Duct Transition:	10" by 3-1/4" top and clear or optional 7" Round	
Installation Type:	Ducted (Recirculating Kit sold separately)	
Electrical:	120 Volts, 60 Hertz, 115 Watts, 1 Amps	
KITS:		
Recirculating Kit	KIT0140997	
Optional Backdraft Damper/No Return Valve 7"	KIT02723	
Optional Duct Transition 7"	KIT02722	

\*The product images shown are for illustration purposes only and may not be an exact representation of the product.

## PLUS FEATURES



**3X LAYER GREASE FILTER** - Elica aluminum mesh filters are a step above competition, featuring triple layered, anodized aluminum that is woven into a highly dense mesh. The thick mesh captures more grease, anodization helps resist staining and provides durability to repeated cleanings in the dishwasher.



**LED LIGHT** - LED lighting is undoubtedly the smartest solution in terms of energy saving. Expected life time of over 20,000 hours, represents the most remarkable advantage of LED light bulbs.