



YOUR AMAZEMENT IS OUR *PASSION*

Every creative process begins with a vision.
A hood becomes a vertical and ergonomic object,
with an excellent design, it also elevates the kitchen
environment by reinventing itself as an element of
furniture, only to turn into a surprising and emotional
lightning point.

All Elica series are able to meet the needs related to the
different ways of living and cooking around the world.



- ° NIKOLATESLA ONE
- ° NIKOLATESLA SWITCH



- ° NIKOLATESLA ONE
- ° NIKOLATESLA SWITCH



- ° NIKOLATESLA ONE
- ° NIKOLATESLA SWITCH



- ° NIKOLATESLA ONE
- ° NIKOLATESLA SWITCH



- ° NIKOLATESLA ONE
- ° NIKOLATESLA SWITCH



- ° NIKOLATESLA ONE
- ° NIKOLATESLA SWITCH
- ° HAIKU COLOR ISLAND
- ° HAIKU COLOR
- ° HAIKU



- ° NIKOLATESLA ONE
- ° NIKOLATESLA SWITCH



- ° NIKOLATESLA ONE
- ° NIKOLATESLA SWITCH
- ° HAIKU COLOR ISLAND
- ° HAIKU COLOR
- ° HAIKU



- ° NIKOLATESLA ONE
- ° NIKOLATESLA SWITCH



- ° NIKOLATESLA ONE
- ° NIKOLATESLA SWITCH



- ° NIKOLATESLA ONE
- ° NIKOLATESLA SWITCH



- ° NIKOLATESLA ONE
- ° NIKOLATESLA SWITCH



- ° NIKOLATESLA ONE
- ° NIKOLATESLA SWITCH
- ° HAIKU COLOR ISLAND
- ° HAIKU COLOR
- ° HAIKU



- ° NIKOLATESLA ONE
- ° NIKOLATESLA SWITCH



- ° NIKOLATESLA ONE
- ° NIKOLATESLA SWITCH
- ° HAIKU COLOR ISLAND
- ° HAIKU COLOR
- ° HAIKU



- ° NIKOLATESLA ONE
- ° NIKOLATESLA SWITCH



- ° NIKOLATESLA ONE
- ° NIKOLATESLA SWITCH
- ° HAIKU COLOR ISLAND
- ° HAIKU COLOR
- ° HAIKU



- ° NIKOLATESLA ONE
- ° NIKOLATESLA SWITCH
- ° NIKOLATESLA ONE



- ° NIKOLATESLA SWITCH
- ° HAIKU COLOR ISLAND
- ° HAIKU COLOR
- ° HAIKU



- ° NIKOLATESLA ONE
- ° NIKOLATESLA SWITCH
- ° HAIKU COLOR ISLAND
- ° HAIKU COLOR



- ° HAIKU COLOR ISLAND
- ° HAIKU COLOR
- ° HAIKU



- ° HAIKU COLOR ISLAND
- ° HAIKU COLOR
- ° HAIKU

INDEX

PRODUCT FEATURES 8

AIR COOKING SERIES 12

NIKOLATESLA SWITCH 14

NIKOLA TESLA ONE 18

RISERVA SERIES 22

EBS52SS1 24

EBF52SS1 28

EBS51SS1 32

EWS52SS1 36

ICONIC SERIES 38

ILLUSION 41

HILIGHT 45

HAIKU ISLAND 49

HAIKU WALL 51

EASY 56

SEASHELL 57

CHROME 58

GLIDE 59

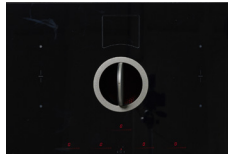

NIKOLATESLA SWITCH



NIKOLATESLA ONE



EBS52SS1



EBF52SS1



EBS51SS1



EWS52SS1



ILLUSION



HILIGHT



HAIKU ISLAND



HAIKU WALL



EASY



SEASHELL



CHROME



GLIDE

INDEX

ELICA PRO SERIES

60

CERVINA

62

CALABRIA

63

LEONE

64

LEONE ISLAND

65

VAVANO

68

VAVANO ISLAND

69

AREZZO

70

TRENTO

71

CAPRI

73

TECHNE SERIES

74

STONEY

76

STONEY ISLAND

77

COMO

80

CINGOLI

81

LUGANO

82

SALICE ISLAND

83

MEZZANO

86

MAGGIORE ISLAND

87

VARNA

88



CERVINA



STONEY



CALABRIA



STONEY ISLAND



LEONE



COMO



LEONE ISLAND



CINGOLI



VAVANO

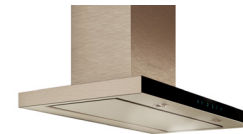

LUGANO



VAVANO ISLAND

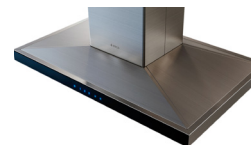

SALICE ISLAND



AREZZO



MEZZANO



TRENTO



MAGGIORE ISLAND



CAPRI



VARNA

INDEX

TECHNE SERIES

VARNA BLACK

FOGLIA

PILATO

ARIA

MODENA

PALERMO

RISE

BELLAGIO

COMFORT

ALLASIO

NEMI

TOBLINO

POTENZA

ASTI

ASTI 30"

SORA

TT

VOLTERRA

GUBBIO

CONTACT INFO

74

89

92

93

94

95

98

99

100

102

105

107

108

109

112

113

114

115

117

119

120



VARNA BLACK



FOGLIA



PILATO



ARIA



MODENA



PALERMO



RISE



BELLAGIO



ALLASIO



NEMI



TOBLINO



POTENZA



ASTI



ASTI 30"



SORA



TT



VOLTERRA



GUBBIO

VENTILATION



CFM REDUCTION SYSTEM

CFM Reduction system (CRS), is an exclusive feature to Elica hoods, which enables the user directly in the glass touch control the maximum blower CFM, to meet local code requirements.

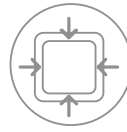

PERIMETER ASPIRATION

This technology draws air through a narrowed channel around a face plate, which increases suction, without increasing blower speed or energy consumption.



TUNE - WHITE

Makes possible to choose the preferred shade of white to match with the lighting in the kitchen, by adjusting the temperature of the LEDs, from a range that goes from yellow light (2700 K) to white light (6000 K).



LED LIGHT

LED lighting is undoubtedly the smartest solution in terms of energy saving. Expected life time of over 20.000 hours, represents the most remarkable advantage of LED light bulbs.



REMOTE CONTROL

Elica's ADA compliant Remote Control, provides added convenience to the typical user, as well as, full function access for those with limited mobility.



TOP PERFORMANCE

Excellent performance for models equipped with this plus. High fume capturing capacity with an average aspiration range of 600 CFM's. with low noise levels, 1.2 - 1.7 sones, at working speed.



TOUCH CONTROLS

Enjoy effortless cooking, and fully control the hood with the tip of a single finger.



HUSH SYSTEM

An exclusive sound deadening technology that effectively reduces sound levels up to 35%, compared to typical range hoods.



LONG LIFE FILTER

One of a kind odour filter, capable of regenerating itself and of lasting up to 3 years. To maintain these characteristics, the filter only requires simple maintenance: wash every 2 or 3 months with hot water and mild soap (also in dishwasher at 65 degrees) and dry in the oven for ten minutes at 100 degrees.



STAINLESS STEEL BAFFLE SLOT

A baffle shaped stainless steel filter with mesh backing allows air to pass but blocks grease, which drops into the high capacity baffle cavities. The design delivers large volume capacity, excellent capture efficiency at all blower speeds, silent operation, plus, durability that will last the life of the hood.



BLOWER KIT

Elica Blower KITS offers installation flexibility that will accommodate most construction requirements, plus provides options related to ventilation power and sound generation.

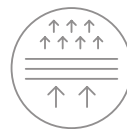

3X LAYER GREASE FILTER

Elica aluminum mesh filters are a step above competition, featuring triple layered, anodized aluminum that is woven into a highly dense mesh. The thick mesh captures more grease, anodization helps resist staining and provides durability to repeated cleanings in the dishwasher.



PROFESSIONAL PERFORMANCE

Special features and high performances for models with high aspiration capacity.



GREASE COLLECTORS

Enjoy effortless cooking, and fully control the hood with the tip of a single finger.



VENTILATION



TOTAL INTEGRATION

These products have been designed to be seamlessly integrated into the kitchen cabinetry whilst maintaining harmony with the surroundings.



UNIQUE MATERIALS

Products designed with unique materials and finishes with great aesthetic impact but also with practical and durable characteristics suitable for kitchen use.



DEEP SILENCE

A noise abatement system that allows you to achieve high silence at all speeds thanks to the elimination of vortices and noise peaks.



HEAT GUARD

Senses extreme temperatures (>158 degrees) and automatically adjusts the blower speed to HIGH



SEAMLESS LOOK

Heavy gauge stainless steel "Seamless" construction that delivers refined elegance.



LED CONSUMER REPLACEABLE BULB

High quality LED lighting usually requires a skilled technician to replace lamps. Avoid this expense with Elica's new LED lamps that enable homeowners to replace in seconds



SUPER EASY INSTALLATION

With the exclusive Elica system, installation can be done in total safety in just a few steps, safeguarding the look of the product and the space in which it is positioned.



REPLACE FILTER ALARM

When activated, your hood will emit a "beep" signal to let you know when is time to replace the carbon filters. See manual to activate feature.



CLEAN FILTER ALARM

When activated, your hood will emit a "beep" signal to let you know it is time to clean your filters. For some models, an intermittent light will remain active until cleaning filter action is completed. See manual to activate feature.

PRODUCT FEATURES

COOKING



POT DETECTOR

Automatically detects a pot on a cooking zones and sends a signal to the hood. Elica hoods with STREAM technology will turn on automatically.



TEMPERATURE MANAGER

For speed and convenience, pre-set cooking zones to automatically turn on to a desired temperature.



TOUCH CONTROL

Enjoy effortless cooking, and fully control each cooking zone with the tip of a single finger.



AIRMATIC

The auto aspiration adjusts automatically to the number and power of the used cooking zones.



BRIDGE ZONES

The special Bridge Zones can work both individually or combined for a more homogeneous cooking using both baking pans and large pots. Thanks to this technology it is the cooktop's surface that adapts itself to the type of pots being used.



STOP & GO

If you are interrupted while cooking, or you have to go into another room, or you just want a break, with just a single movement, pressing the Stop&Go button, you can switch off all the cooking zones and walk away with complete confidence and safety.



CERAMIC FILTERS

This recirculating filter is suitable for the most challenging cooking environment, given its superior ability to filter and purify the air. The new Elica Technology is able to achieve filtering threshold of 82% against the market average of 60% it can be regenerated up to 5 years if placed in oven at 390° F for 45 minutes every 2/3 months.



UNDERCABINET REFRIGERATION



EPC TECHNOLOGY

Elica Perfect Climate with double air duct cooling system. Meet Elica's Intelligent System with sensors that deliver precise and consistent temperature & humidity evenly throughout the entire compartment, so that all stored bottles are preserved under the same conditions.



ECO MODE

Sustainable and environmentally friendly: Eco-Mode will maintain optimum interior temperature, while saving energy consumption turning the lights OFF.



CONCEALED HINGE

Door hinges are hidden within the door and do not extend above the top of the door, allowing for a cleaner, more refined appearance, plus enabling the refrigerator to fit tighter within cabinetry.



QUIET OPERATION

Elica offers a Speed-controlled motor, reducing exterior sound levels, while offering high ventilation performance to keep constant interior temperature and dampening any possible vibration that could disturb the preservation of wine or beverages.



DOOR OPEN ALARM

To save energy and ensure proper preservation of your beverages, all Elica Undercabinet Refrigeration products come with a Door-Open Alarm, that will repeatedly beep when the door has been left ajar for longer than 5 minutes.



HIGH EFFICIENCY CARBON FILTERS

Elica's advanced Carbon Filters remove odors and other gaseous pollutants from the air, ensuring fresh and pure environment.



AIR COOKING

NIKOLATESLA SWITCH

DESIGN FABRIZIO CRISÀ



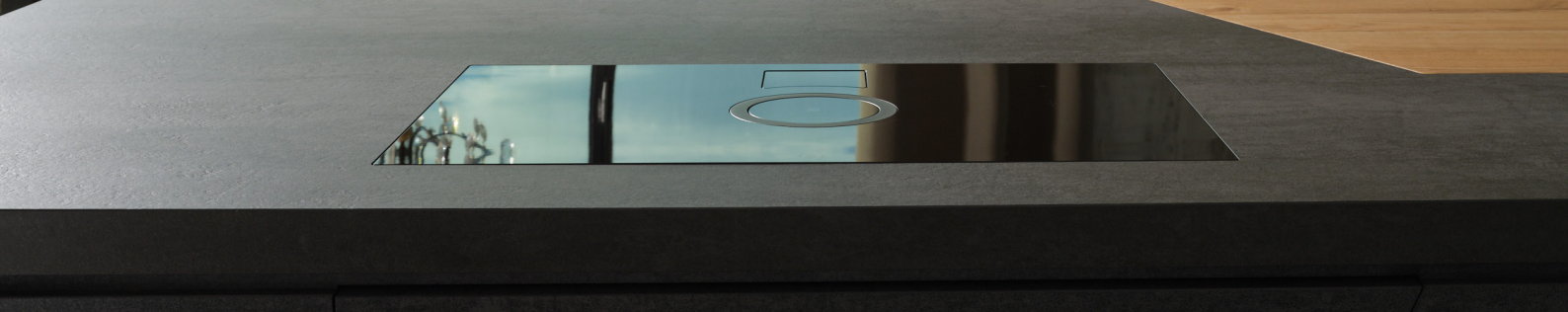



NIKOLATESLA SWITCH

DESIGN FABRIZIO CRISÀ

36" x 20 1/16" x 8 1/4"
 Duct Out or Recirculating
 Black Glass

Extremely clean lines give life to a truly exclusive appliance, NikolaTesla Switch, a concentrate of design and technology through which Elica has revolutionized the daily cooking experience.

A return to the origins with a simple induction cooktop, featuring continuous surfaces and a display that becomes completely invisible in stand-by mode. The extraction area is cleverly hidden by a black glass and steel disk, characterizing the product without clashing with the other elements.

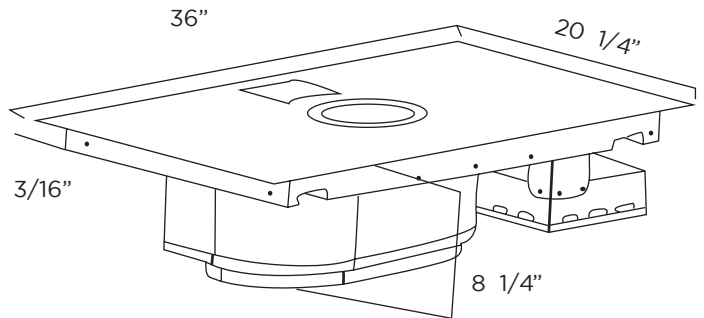

INDUCTION COOKTOP

Controls	Slider Touch Control 9 Speed + Booster Ventilation
Power Consumption	7.4 kW
Electrical Frequency	440 Watts aT 3.3 Amps
Voltage	240V - 7.8kW at 32.5 Amps 208V - 7.1kW at 34.1 Amps
Cooking Zones	1 7,1 x 7,9 inches - 2,1 - 3,7 kW 2 7,1 x 7,9 inches - 2,1 - 3,7kW 3 7,1 x 7,9 inches - 2,1 - 3,7kW 4 7,1 x 7,9 inches - 2,1 - 3,7kW

ASPIRATION SYSTEM

Controls	Slider Touch Control 3 Speed + Booster Ventilation
CFM	400 CFM
Suction speed	5,1 m/s
Noise (sones)	Min 2.2 , Max 5
Ventilation	160 W

FEATURES



*Anodized aluminum 6 layer grease filter included

NIKOLATESLA SWITCH ENS436BL

SPACE SAVING DESIGN

NikolaTesla not only integrates perfectly within the kitchen without obstructing your view, but also, thanks to its slim design optimizes the space under the unit allowing the addition of drawers or useful cabinet space.

AIRMATIC FUNCTION

NikolaTesla Smart Sensor Technology is able to detect heat and humidity levels and automatically adjusts the fan speed to fit your cooking needs.



EASY CLEANING

The completely smooth surface of the NikolaTesla simplifies cleaning. In addition, the dishwasher safe exclusively designed grease filter can be accessed from the top of the surface. Any spilled liquids during cooking will be captured in the cavity below the grease filter and can be easily removed by opening the drain valve and wiping out any residual with a cloth. In the recirculating version, the high performing new generation ceramic odor filters are accessible from the top part of the cooktop, making cleaning and maintenance a cinch.

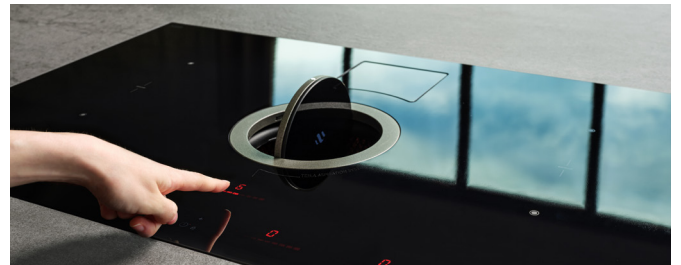

REVOLUTIONARY COOKING

INDUCTION TECHNOLOGY WITH BUILT-IN ASPIRATION THAT COMBINES ITALIAN DESIGN WITH FUNCTIONALITY

NikolaTesla Switch is the latest Induction Cooktop with built-in Aspiration by Elica, with innovative functions and unique performance, representing the highest expression of technology and design. Available in a sophisticated black ceramic glass finish and measures 36" in width. The central disk which allows 360°- degree rotation has two exterior finishes - on one side is black glass and on the other is steel. When closed on either side (black glass or steel), the central disk is completely flush with the cooktop surface, cleverly concealing the aspiration system. High CFM performance, approximately 5 times faster than the speed of rising fumes, ensures efficient fume and moisture extraction. Duct-out and recirculating versions.

INSTALLATION FLEXIBILITY

Nikolatesla SERIES cooktops have been designed to adapt to the most varied installation configurations. These are the main examples of the infinite range of possibilities that can be developed.

DUCT OUT

RECIRCULATING

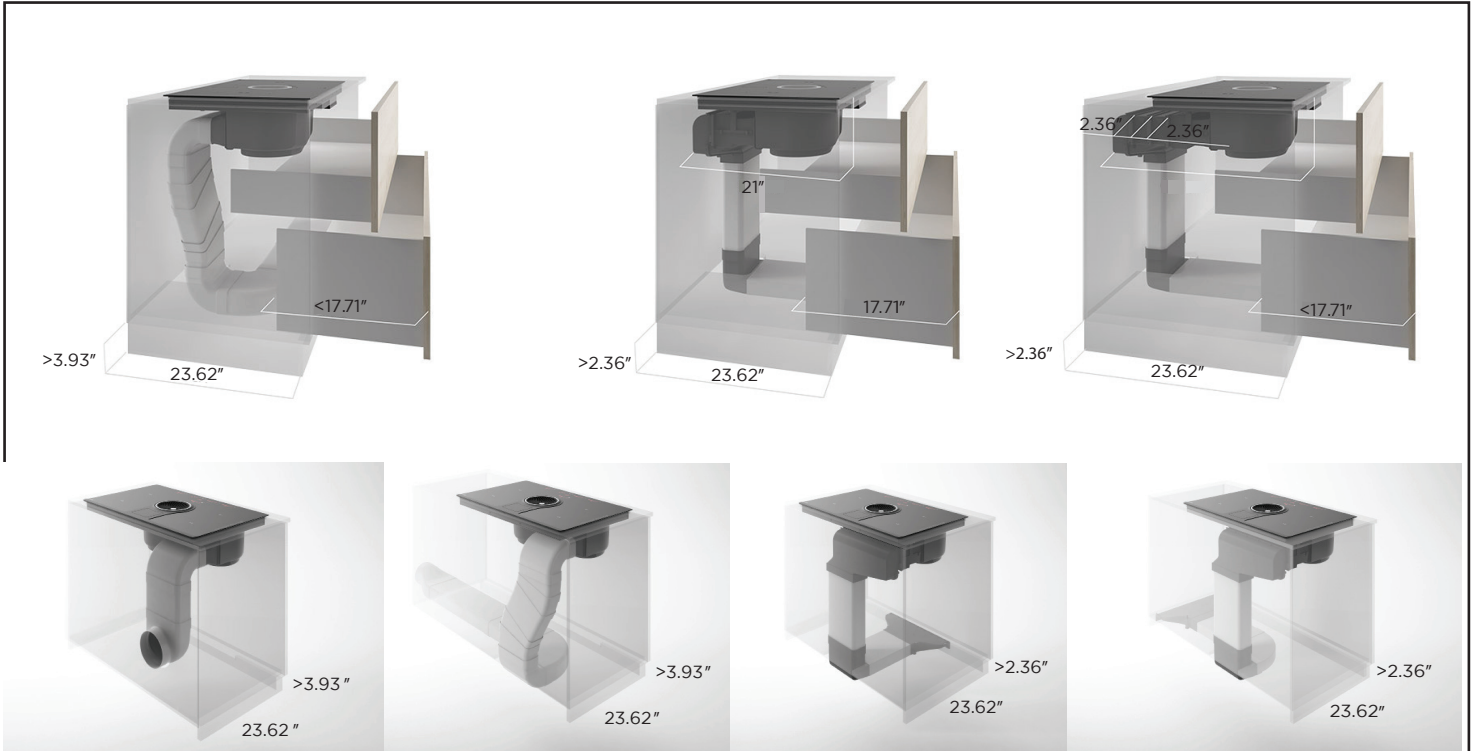

For the Duct-Out version installation, it will be necessary to leave a high stand of 3.93\"/>

Please note, most ducting insulation provided by the installer are rigid, images may vary from final installations results according to each user needs.

TRADITIONAL INSTALLATION

FLUSH MOUNTED INSTALLATION

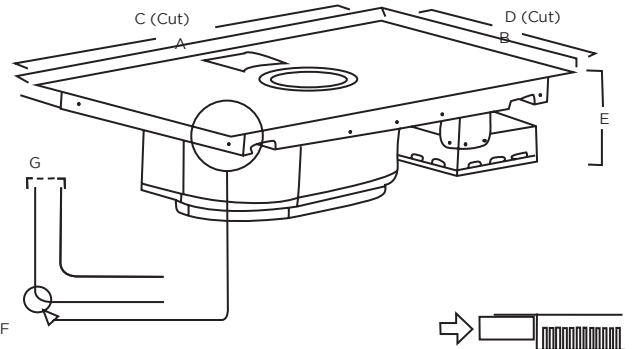
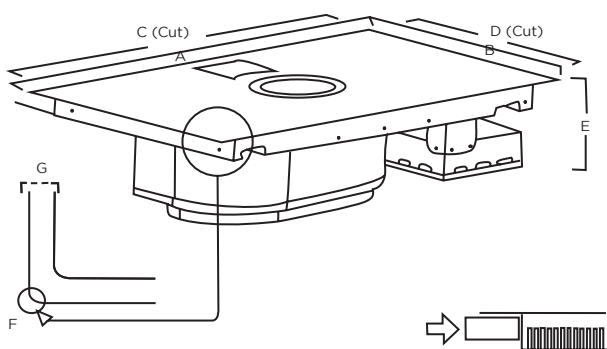

ONE	
A	32 11/16"
B	20 1/4"
C	31 49/64"
D	19 3/8"
E	8 1/4"
F	7/16"
G	Min 1 15/16"

SWITCH	
A	36 1/16"
B	20 1/4"
C	31 3/4"
D	19 3/8"
E	8 1/4"
F	7/16"
G	Min 1 15/16"

ONE	
A	32 15/16"
B	20 1/4"
C	31 49/64"
D	19 3/8"
E	8 1/4"
F	3/16"
G	7/16"

SWITCH	
A	36 1/16"
B	20 1/4"
C	31 1/16"
D	19 3/8"
E	8 1/4"
F	3/16"
G	1/2"



NIKOLATESLA ONE

DESIGN FABRIZIO CRISÀ







NIKOLATESLA ONE

DESIGN FABRIZIO CRISÀ

32 1/16" x 20 1/16" x 8 1/4"
 Duct Out or Recirculating
 Black Glass

With the advantages of cooking speed and easy maintenance common with induction cooktops, NIKOLATESLA ONE adds central ventilation for high performance capture of grease, smoke and odor. Completely invisible Aspiration system, that can be easily controlled with the touch of your finger. The aspirating system, positioned in the central zone, reaches high performance levels, in terms of fume extraction, noise level and energy efficiency.

Thanks to the direct communication with the cooktop, it is able to receive information from the cooking zones, and automatically calibrates the ideal aspiration level, so that the user only needs to worry about cooking, while at the same time reducing energy consumption. With filters included the NikolaTesla One can be installed as ducted or recirculated.

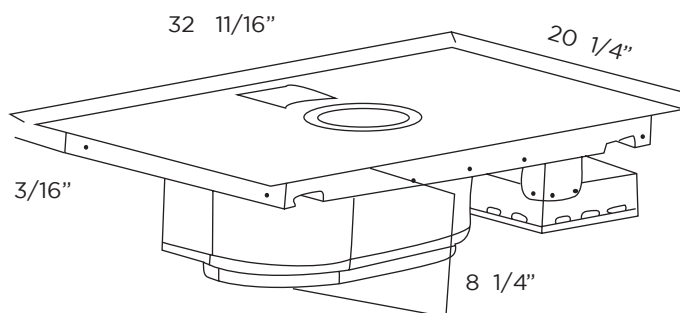

ASPIRATION SYSTEM

Controls	Slider Touch Control 3 Speed + Booster Ventilation
CFM	400 CFM
Suction speed	5,1 m/s
Noise (sones)	Min 2.2 , Max 5
Ventilation	160 W

INDUCTION COOKTOP

Controls	Slider Touch Control 9 Speed + Booster Ventilation
Power Consumption	7.4 kW
Electrical Frequency	440 Watts aT 3.3 Amps
Voltage	240V - 7.8kW at 32.5 Amps 208V - 7.1kW at 34.1 Amps
Cooking Zones	1 7,1 x 7,9 inches - 2,1 - 3,7 kW 2 7,1 x 7,9 inches - 2,1 - 3,7kW) 3 7,1 x 7,9 inches - 2,1 - 3,7kW) 4 7,1 x 7,9 inches - 2,1 - 3,7kW)

FEATURES



*Anodized aluminum 6 layer grease filter included

NIKOLATESLA ONE

ENT432BL

TRIM KIT 36"

KIT0155746

RISERVA

RISERVA - EBS52SS1

UNDERCABINET REFRIGERATION







EBS52SS1

24"
Beverage & Wine Center -
SINGLE DOOR SINGLE ZONE

A brilliant solution that meet all your needs, RISERVA - EBS52SS1 24", features two different cooling zones, adjustable to different temperatures to preserve a variety of beverages and wines to their optimum freshness.

Its UV double layered resistant Glass Door shields bottles from aging, while Elica's Perfect Climate technology (EPC) ensures a consistent air flow between bottles for optimum preservation.

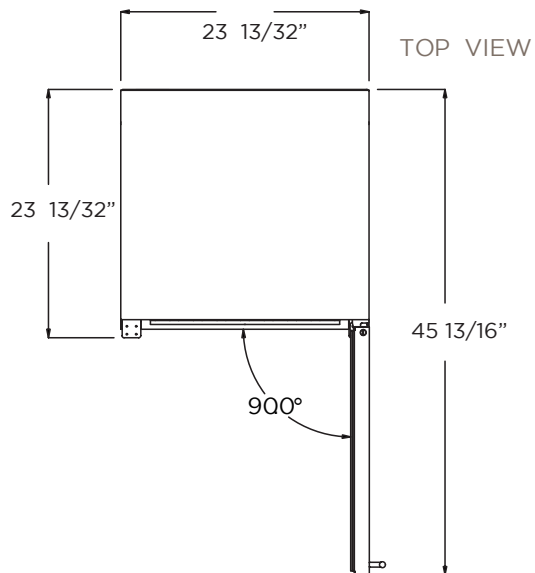
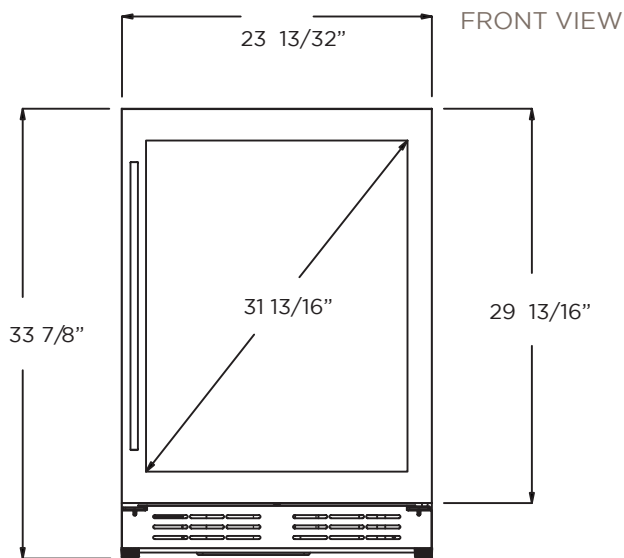

MODELS

24" Undercabinet Beverage and Wine Center - Single Door Single Zone	EBS52SS1
---	----------

PRODUCT DESCRIPTION EBS52SS1		DOOR	
Width	24"	Door Handle	Tubular
Dimensions	23 13/32" W x 33 13/16" H x 23 5/8"	Door Glass	Tinted Dual Pane, Low-e Argon-filled
Weight	128 lbs	Reversible Door	Yes
Installation Type	Built-in and Free Standing	ELECTRICAL SPECIFICATIONS	
Refrigerant Type	R600a	Compressor Brand	Embraco
Volume	4.8 cu ft (135L)	Min. Circuit Required	15 A
Sound Level	39 dBA	AC Power	110-120V/60HZ
Door Finish	304 Stainless Steel + Glass	Amperage	0.95 A
Cabinet Finish	Black	Plug Type	B
Interior Finish	Black	OTHERS	
Hinge Design	Concealed	Superior Full Extension Racks	
Lighting	3 Level White LED	Beverage Shelving made of Plexiglass	
Controls	Capacitive Touch with Display with white numbers	Premium Beachwood Wine Racks	
		White LED Lights with 3 level KELVIN shade adjustment	
COOLING ZONE 1 - BEVERAGES		Anti Damping System	
Total Capacity	72 cans (12 oz cans)	Double Panel Glass Door, UV coated	
Temperature Range	34 to 50°F	Sabbath Mode	
Shelving	2 Adjustable Slide-Out Tempered Glass Shelves	Stylish look with tubular handle	
COOLING ZONE 2 - WINES		KITS	
Total Capacity	14 Bottles of Wine (25 oz)	PRO Handle	KIT0175505
Temperature Range	40 to 64° F	WARRANTY	
Shelving	1 Full Extension Rack of Wood with Metal Front Trim	2+1 Year Parts and In-Home Labor Warranty. Third year awarded after product registration on www.elica.com	





RISERVA - EBF52SS1

UNDERCABINET REFRIGERATION





EBF52SS1

24"
Beverage & Wine Center -
FRENCH DOOR DUAL ZONE

A paradigm of sophisticated design and seamless construction, RISERVA is your best ally when preserving the freshness of your beverages. Dual Compartments and Dual Cooling zones, offer the elegance of a wine cellar, fused with the convenience of a beverage center.

It holds up to 60 cans (12oz) within the Beverage Zone and up to 21 bottles of wine (21oz) in the Wine Zone. Optimum preservation is ensured thanks to the natural Beechwood shelves, highest quality components that reduce vibration, plus Elica's Perfect Climate technology (EPC) that maintains consistent and even temperature distribution.

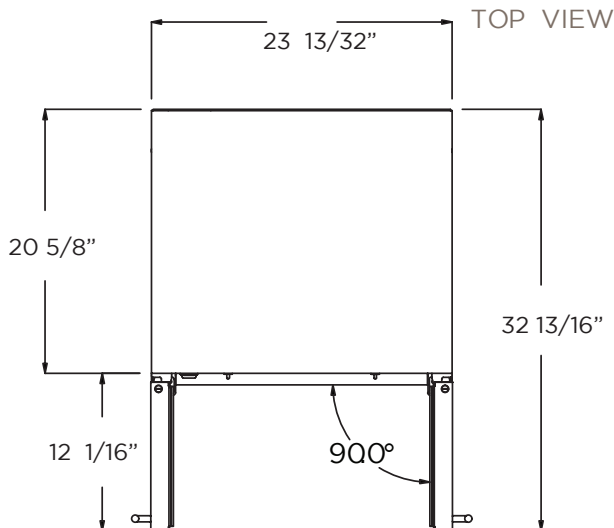
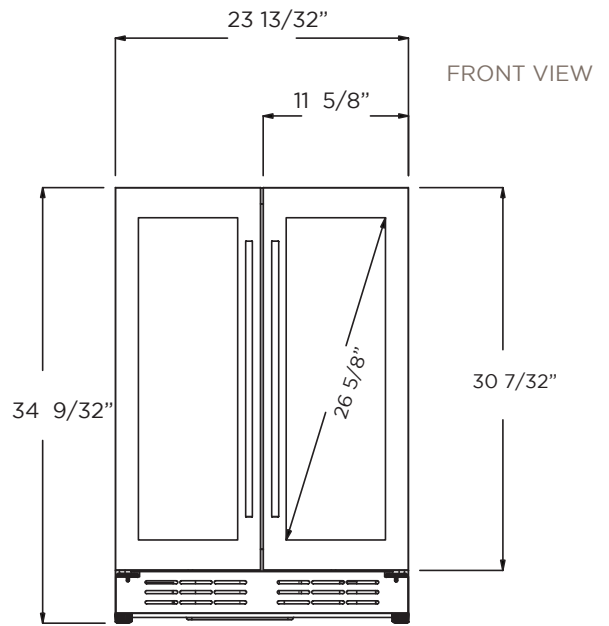

MODELS

24" Undercabinet Beverage and Wine Center - French Door Dual Zone

EBF52SS1

COMMERCIAL CODE - EBF52SS1		DOOR	
Width	24"	Door Handle	Tubular
Dimensions	23 13/32" W x 34 13/16" H x 22 13/32" D	Door Glass	Tinted Dual Pane, Low-e Argon-filled
Weight	117 lbs	Reversible Door	No
Installation Type	Built-in and Free Standing	ELECTRICAL SPECIFICATIONS	
Refrigerant Type	R600a	Compressor Brand	Embraco
Volume	4.8 cu ft (135L)	Min. Circuit Required	15 A
Sound Level	39 dBA	AC Power	110-120V/60HZ
Door Finish	304 Stainless Steel + Glass	Amperage	0.95 A
Cabinet Finish	Black	Plug Type	B
Interior Finish	Black	OTHERS	
Hinge Design	Concealed	Superior Full Extension Racks	
Lighting	3 Level White LED	Beverage Shelving made of Plexiglass	
Controls	Capacitive Touch with Display with white numbers	Premium Beachwood Wine Racks	
		White LED Lights with 3 level KELVIN shade adjustment	
COOLING ZONE 1 - BEVERAGES		Anti Damping System	
Total Capacity	> 60 Cans (12 oz)	Double Panel Glass Door, UV coated	
Temperature Range	34 to 68 °F	Sabbath Mode	
Shelving	3 Adjustable Slide-Out Glass Shelves with Plastic Front	Stylish look with tubular handle	
		KITS	
COOLING ZONE 2 - WINES		PRO Handle	KIT0175505
Total Capacity	21 Bottles of Wine (25 oz)	WARRANTY	
Temperature Range	34 to 68 ° F	2+1 Year Parts and In-Home Labor Warranty. Third year awarded after product registration on www.elica.com	
Shelving	6 Pieces Beachwood Shelves with Metal Front Trim		





RISERVA - EBS51SS1

UNDERCABINET REFRIGERATION





EBS51SS1

24"
Beverage Center
SINGLE DOOR SINGLE ZONE

RISERVA - EBS51SS1 creates the dream conditions for your favorite seltzer drinks. This 24" undercabinet refrigerator has the capacity to fit up to 100 cans (12oz).

Featuring 3 adjustable slide out Plexiglass shelves, 304 Stainless Steel frame with double layered UV resistant glass door and an exclusive concealed hinge design that delivers a more refined appear and tighter fit within cabinetry.

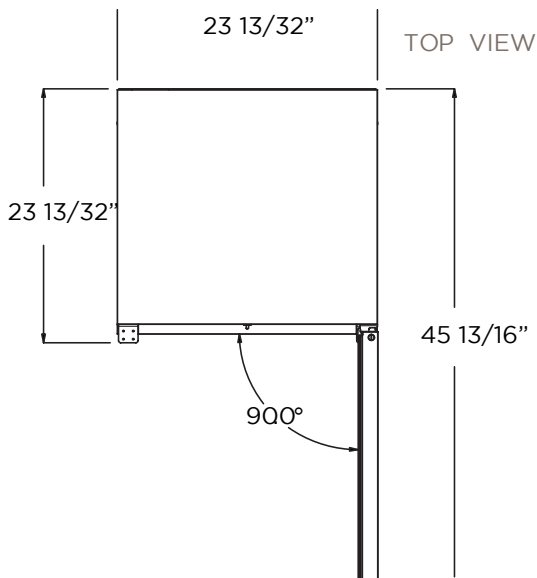
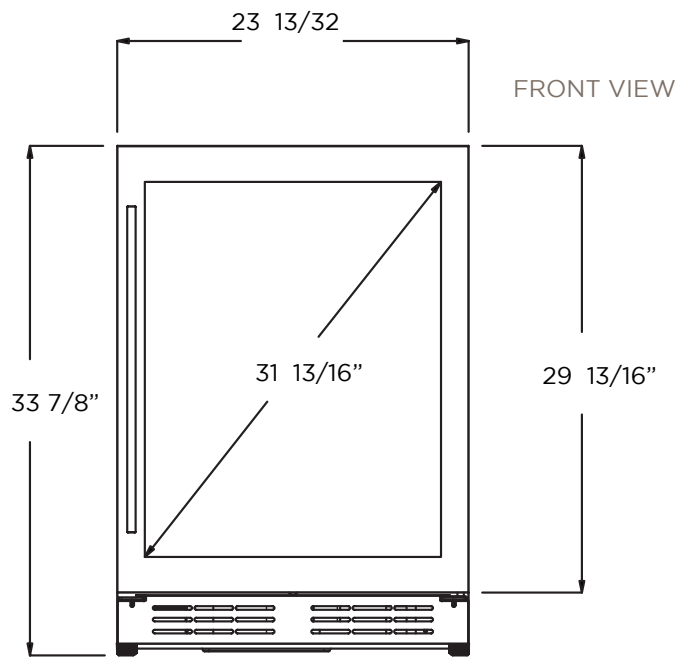

MODELS

24" Undercabinet Beverage Center - Single Door Single Zone EBS51SS1

PRODUCT DESCRIPTION EBS51SS1		ELECTRICAL SPECIFICATIONS	
Width	24"	Compressor Brand	Embraco
Dimensions	23 13/32" W x 33 13/16" H x 23 5/8" D	Min. Circuit Required	15A
Weight	128 lbs	AC Power	110-120V/60HZ
Installation Type	Built-in and Free Standing	Amperage	0.95A
Refrigerant Type	R600a	Plug Type	B
Volume	4.8 cu ft (135L)	OTHERS	
Total Capacity	> 120 cans (12 oz cans)	Superior Full Extension Racks	
Temperature Range	33 to 65°F	Beverage Shelving made of Plexiglass	
Sound Level	39 dBA	White LED Lights with 3 level KELVIN shade adjustment	
Door Finish	304 Stainless Steel + Glass	Anti Damping System	
Cabinet Finish	Black	Double Panel Glass Door, UV coated	
Interior Finish	Black	Sabbath Mode	
Hinge Design	Concealed	Stylish look with tubular handle	
Lighting	3 Level White LED		
Shelving	3 Adjustable - Slide Out-Tempered Glass Shelves with Wood and Metal front Trim (without rollers)	KITS	
		PRO Handle	KIT0175505
Controls	Capacitive Touch with Display with White Numbers		
DOOR		WARRANTY	
Door Handle	Tubular	2+1 Year Parts and In-Home Labor Warranty. Third year awarded after product registration on www.elica.com	
Door Glass	Tinted Dual Pane, Low-e Argon-filled		
Reversible Door	Yes		





RISERVA - EWS52SS1

UNDERCABINET REFRIGERATION





EWS52SS1

24"
Wine Cellar
SINGLE DOOR DUAL ZONE

RISERVA - EWS52SS1 with dual temperature zones is designed to store a variety of quality wines and preserve them under optimal conditions.

As the global ventilation leader, Elica understands in depth, the importance of maintaining the right temperature, humidity, light and low vibration to ensure the right environment for safe preservation and aging. RISERVA natural beechwood shelves are full extension for easy and safe access to each bottle.

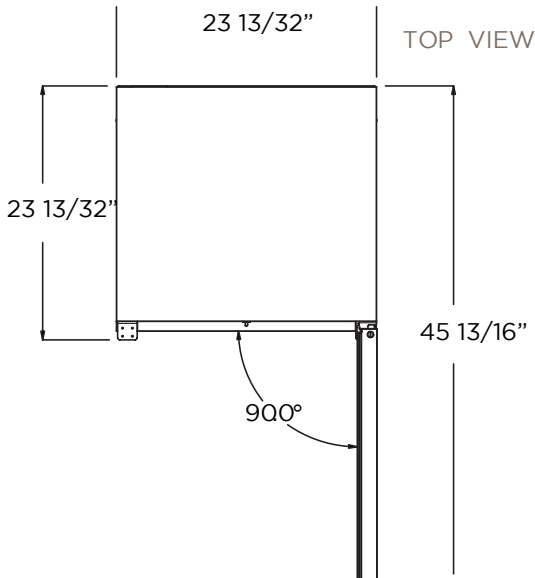
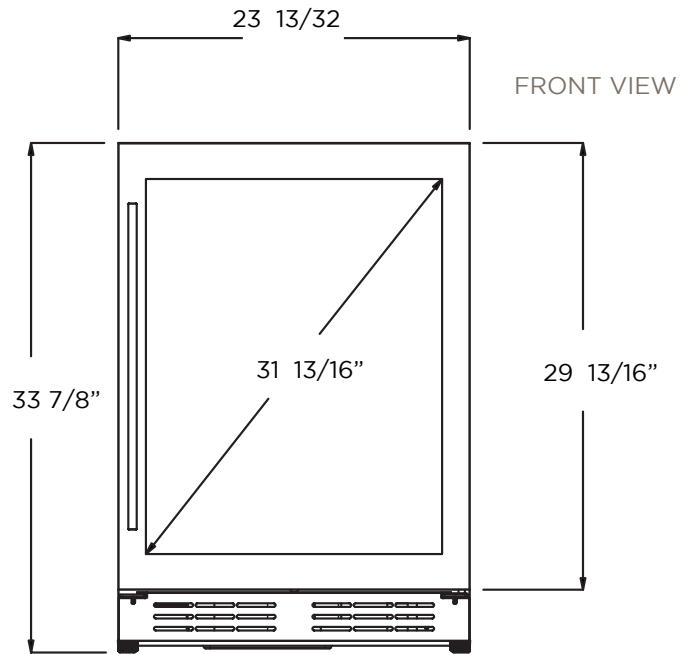

MODELS

24" Undercabinet Wine Cellar- Single EWS52SS1
Door Dual Zone

PRODUCT DESCRIPTION EWS52SS1		DOOR	
Width	24"	Door Handle	Tubular
Dimensions	23 13/32" W x 33 13/16" H x 23 5/8" D	Door Glass	Tinted Dual Pane, Low-e Argon-filled
Weight	128 lbs	Reversible Door	Yes
Installation Type	Built-in and Free Standing	ELECTRICAL SPECIFICATIONS	
Refrigerant Type	R600a	Compressor Brand	Embraco
Volume	4.8 cu ft (135L)	Min. Circuit Required	15A
Sound Level	39 dBA	AC Power	110-120V/60HZ
Door Finish	304 Stainless Steel + Glass	Amperage	0.95 A
Cabinet Finish	Black	Plug Type	B
Interior Finish	Black	OTHERS	
Hinge Design	Concealed	Superior Full Extension Racks	
Lighting	3 Level White LED	Premium Beachwood Wine Racks	
Controls	Capacitive Touch with Display with white numbers	White LED Lights with 3 level KELVIN shade adjustment	
		Anti Damping System	
COOLING ZONE 1 - WHITE WINES		Double Panel Glass Door, UV coated	
Total Capacity	16 Bottles of Wine (25 oz)	Sabbath Mode	
Temperature Range	40 to 50°F	Stylish look with tubular handle	
Shelving	2 Full Extension Racks of Wood with Metal Front Trim	KITS	
COOLING ZONE 2 - RED WINES		PRO Handle	KIT0175505
Total Capacity	36 Bottles of Wine (25 oz)		
Temperature Range	50 to 64° F	WARRANTY	
Shelving	3 Full Extension Racks of Wood with Metal Front Trim	2+1 Year Parts and In-Home Labor Warranty. Third year awarded after product registration on www.elica.com	



ICONIC

ILLUSION

DESIGN FABRIZIO CRIS







ILLUSION Metal White with white frame

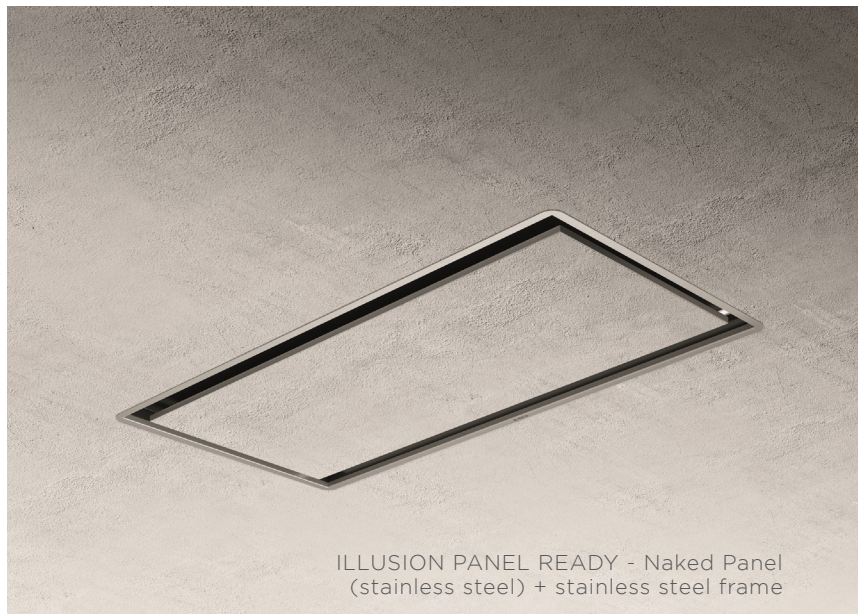

ILLUSION PANEL READY - Naked Panel (stainless steel) + stainless steel frame





ILLUSION

DESIGN FABRIZIO CRISÀ

40"
Duct Out with Recirculating Kit sold separately
Ceiling Hood

FIRST PANEL-READY CEILING HOOD IN THE MARKET, perfectly fitting the ceiling texture of the living space, disappearing like a true Illusion. Also naturally saves valuable kitchen space and frees the area of inconvenient obstructions cleverly hiding a powerful extraction system that guarantees always clean air in the living space. Combining discreet shapes and high performance, Illusion has been created for consumers who ask for an essential and bespoke style without compromises on functionality.

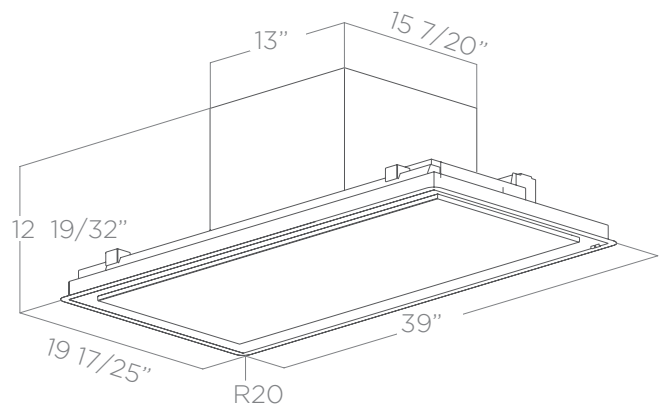

FALSE CEILING CUT: 18 57/64 X 38 37/64

SPECIFICATIONS

Dimensions	40" x 20"
Illumination	Strip LED 2 x 14 W
Electrical	120 V 60 Hz

WHITE

Controls 3 Speed + Booster Remote Control

CFM 600 CFM

NAKED / PANEL READY

3 Speed + Booster Remote Control

600 CFM

KITS

Recirculating Kit KIT0167875



MODELS

ILLUSION Metal White with White Frame EIL640WH

ILLUSION Naked Panel (Stainless Steel) PANEL READY EIL640DW

The lighting is entrusted to two LED strips: the dimmer allows you to change the intensity of the light, while the innovative Tune-White system guarantees the best shade of white by adjusting the light temperature

*FLEXIBLE INSTALL
Blower offers 5 possible exit directions, allowing you to decide on which side to attach the air outlet duct.

HILIGHT

DESIGN FABRIZIO CRISÀ





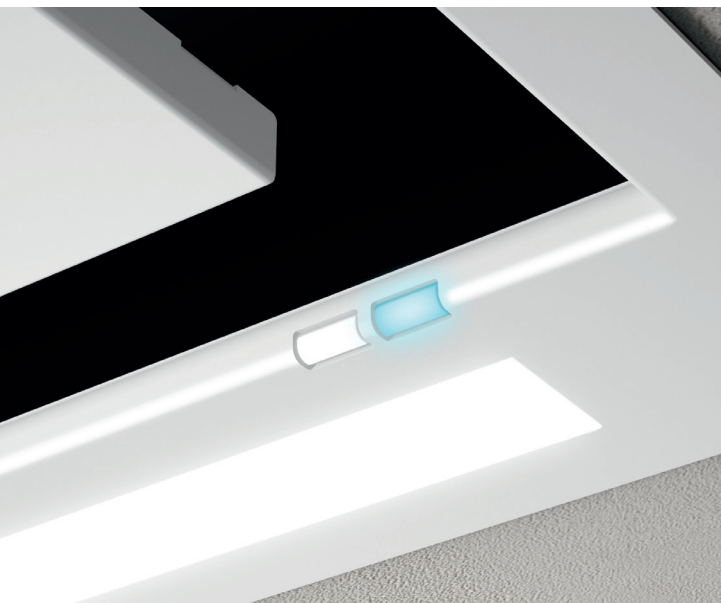



HILIGHT

DESIGN FABRIZIO CRISÀ

39"

Duct Out with Recirculating Kit sold separately
Ceiling Hood

Characterized by essential lines, Hilight totally fits the kitchen architectural style with a perfectly flush installation, leaving the space above the cooktop completely free and without view obstructions.

Comfort in the kitchen is guaranteed by the powerful and silent suction heart concealed in the ceiling combined with the adaptable light intensity that create the right environment in every moment. All maintenance operations can be carried on opening the side panel without any effort, and in this way, the hood can be easily preserved clean and fully functional.

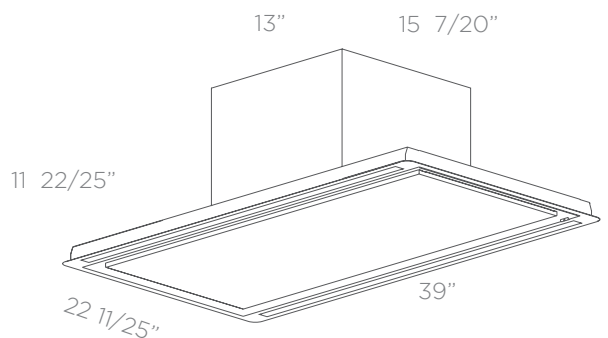

FALSE CEILING CUT: 21 13/20" X 38 1/2"

SPECIFICATIONS

Dimensions	39" x 22 4/9"
Illumination	Strip LED 2 x 14 W
Electrical	120 V 60 Hz

	WHITE	STAINLESS STEEL
Controls	3 Speed + Booster Remote Control	3 Speed + Booster Remote Control
CFM	600 CFM	600 CFM
Noise, sones at working speed	2.1 Sones	2.1 Sones

KITS

Recirculating Kit	KIT0167875
-------------------	------------



MODELS

White Glass with Metal White Frame	EHL640WH
Stainless Steel	EHL640SS

The lighting is entrusted to two LED strips: the dimmer allows you to change the intensity of the light, while the innovative Tune-White system guarantees the best shade of white by adjusting the light temperature

***FLEXIBLE INSTALL**
Blower offers 5 possible exit directions, allowing you to decide on which side to attach the air outlet duct.





elica

HAIKU

DESIGN FABRIZIO CRISÀ



12.5" STAINLESS



48" WHITE KRION



48" BLACK GLASS



HAIKU ISLAND

DESIGN FABRIZIO CRISÀ

12.5" , 48" , 70"

Duct Out Or Recirculating with Kit sold separately

Shapes, materials and solutions. At Elica, our strong belief in research means that even the choice of materials becomes an essential element in the innovation process. With sophisticated black iron grates, the grids are kept attached to the casting by means of magnets mounted on the hood. Therefore, the locking system prevents any accidental fall. Available in different sizes and different materials: full stainless steel, extra clear tempered glass with black screen printed and White Intense Krion.

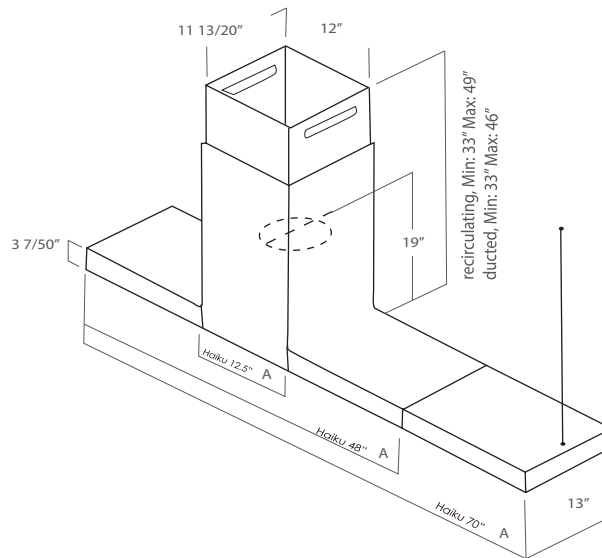

SPECIFICATIONS

Illumination Strip LED 1X7 W 3500 K
Duct Transition 5"

Controls 3 Speed + 2 Booster Touch Control

Filter 6 layer mesh filter + sophisticated black iron grates

CFM 600 CFM

Noise (sones) at working speed 1.8

KITS AND ACCESSORIES

Recirculating Kit CFC0141725AUL



MODELS

12.5" STAINLESS STEEL HAIKU ISLAND	EHI613SS
48" STAINLESS STEEL HAIKU ISLAND	EHI648SS
48" BLACK GLASS HAIKU ISLAND	EHI648BL
48" WHITE KRION HAIKU ISLAND	EHI648WH
70" STAINLESS STEEL HAIKU ISLAND	EHI670SS



36" WHITE KRION

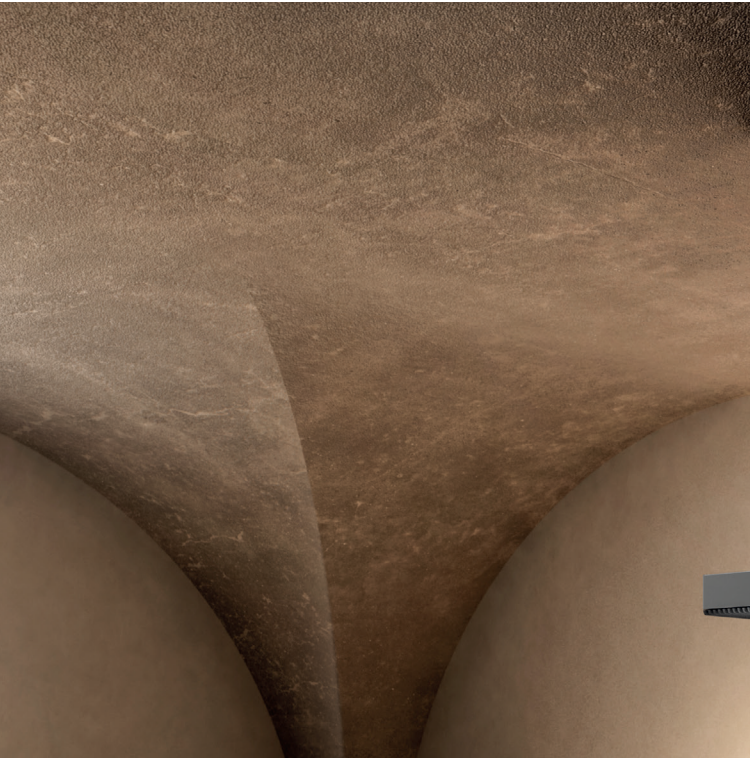

36" BLACK GLASS



36" BLACK GLASS



HAIKU WALL

DESIGN FABRIZIO CRISÀ

12.5" , 24" , 36" , 48"

Duct Out Or Recirculating with Kit sold separately

Elica is the first on the market to have created the innovative SHIFT 3238 SYSTEM, which allows millimetric adjustment of the depth of the product from 12.5" to 15", guaranteeing perfect alignment of the hood with the front edge of the cabinets.

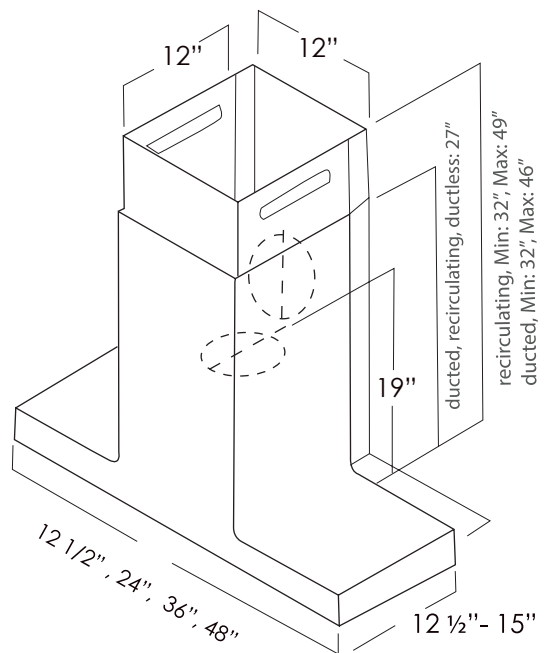

SPECIFICATIONS

Illumination	Strip LED 1X7 W 3500 K
Duct Transition	5"
Controls	3 Speed + 2 Booster Touch Control
Filter	6 layer mesh filter + sophisticated black iron grates
CFM	600 CFM
Noise (sones) at working speed	1.8

KITS AND ACCESORIES

Recirculating Kit CFC0141725AUL



MODELS

12.5" STAINLESS STEEL HAIKUWALL	EHK613SS
24" STAINLESS STEEL HAIKU WALL	EHK624SS
36" STAINLESS STEEL HAIKU WALL	EHK636SS
48" STAINLESS STEEL HAIKU WALL	EHK648SS
36" BLACK GLASS HAIKU WALL	EHK636BL
36" WHITE KRION HAIKU WALL	EHK636WH

UNIQUE MATERIALS

STAINLESS STEEL

Material par excellence for this category of products. Traditional with a professional appeal of the product.

ULTRA CLEAR BLACK TEMPERED GLASS

A glass with a very high strength and low iron content, which enhances its transparency properties.

BRIGHT WHITE KRION®

The composition - two-thirds natural minerals and a small percentage of resins - embedded with anti-bacterial properties and easy maintenance due to the super low porosity.



BRIGHT WHITE KRION®

100% RECYCLABLE

White KRION® is a new generation solid surface, a material that is warm to the touch, similar to natural stone. Also, it is ecological since it can be 100% recycled. It is composed of two-thirds of natural minerals and a small percentage of high-strength resins.

ANTIBACTERIAL

White KRION® has antibacterial properties related to the demonstrated photocatalytic capacity of the material: the KRION® surface, which prevents the bacteria formation. Also, its hardness, strength and durability makes possible to have a reduced maintenance, as well as easy repair and cleaning due to the super low porosity.



SOPHISTICATED BLACK IRON GRATES

SOPHISTICATED BLACK IRON GRATES FINISH HAIKU WITH UNIQUELY UNIFORMED DESIGN

Haiku's unique style is enhanced by the black iron grates attached to the casing by means of magnets mounted on the hood, which gives the product solidity and professionalism and creates a double barrier for filtering fats.

To remove the grids, just tilt them 45° and then unfasten them from the locking system that prevents their release at any other inclination. Once removed, it is possible to easily extract the grease filter and wash it in the dishwasher.

Haiku can easily be converted from Duct-Out to recycling version thanks to an odor filter accessory which guarantees the elimination of unwanted odors in the kitchen.

EASY TO CLEAN

Unlike all other T-Shape hoods, Haiku features no discontinuity between the body of the hood and the chimney. The monolithic front of the hood is completely linear, making Haiku especially easy to clean.



USER INTERFACE

CONTROLS

Back-lit and transparent controls emerge from the side of the product to ensure maximum ease of use and leave the front surface uncluttered.

LIGHTNING

Provided by a powerful, highly effective STRIP LED that runs the entire length of the hood, ensuring a uniform distribution of light (strip LED 1x7 W - natural light 3500°K)

SEASHELL

DESIGN FABRIZIO CRISÀ





elica



EASY

DESIGN FABRIZIO CRISÀ

20"
Recirculating

Easy brilliantly glossy finish reflects the world around it like a kaleidoscope, and provides a powerful visual impact, while the modern, clean-lined definition makes it easily adaptable to a variety of styles and environments.

Many are stunned by Easy 's pendent light appearance, touch control, LED lighting and perimeter aspiration are pleased to find its decorative qualities by a high functioning range hood hidden within.

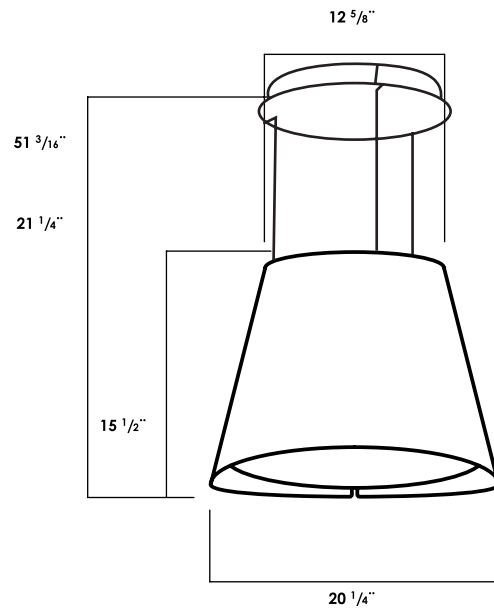

SPECIFICATIONS

Illumination 3x2 LED 5W 4000K
Electrical 220V - 60 Hz, Amps - 4

Controls Touch Control 3 Speed + Booster

Filter Aluminum Mesh Filter + Perimeter Aspiration

CFM 355 CFM

Noise (sones) at working speed 1.65-5

KITS AND ACCESSORIES

Optional Wall Mounting Bracket Kit KIT0121394
High Ceiling Extension Kit KIT01921



MODELS

20" EASY STAINLESS STEEL EES320SS
20" EASY WHITE EES320WT



SEASHELL

DESIGN FABRIZIO CRISÀ

20"
Recirculating

Seashell is a hood characterized by its large dimensions, making it perfect for spacious island kitchens. Made from exclusive materials, it perfectly combines the functions of a hood and lamp and its perimeter aspiration offers benefits for the highest performance. In addition, its round shape and bright lights give it the appearance of a stylish pendant lamp.

The ideal complement for a refined and contemporary kitchen is Seashell, which has a remote control and is available in black, white and stainless steel.

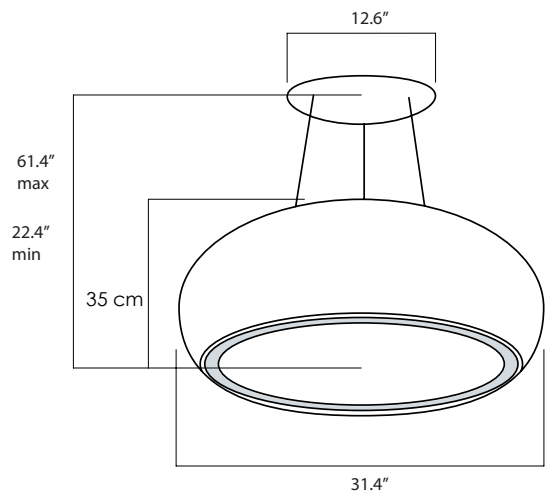

SPECIFICATIONS

Illumination	3x2 LED 5W 4000K
Electrical	220V - 60 Hz, Amps - 4

Controls Touch Control 3 Speed + Booster

Filter Aluminum Mesh Filter + Perimeter Aspiration

CFM 400 CFM*

Noise (sones) at working speed 1.8 working speed

KITS AND ACCESSORIES

Optional Wall Mounting Bracket Kit	KIT0121394
High Ceiling Extension Kit	KIT01921



MODELS

20" EASY STAINLESS STEEL	EES320SS
20" EASY WHITE	EES320WT

* FREE BLOWER TYPE
**HVI AIRFLOW TEST PROCEDURE, HVI PUBLICATION 916, 29/09/2015 FOR 230 MAX CFM,



CHROME

DESIGN FABRIZIO CRISÀ

23"
Duct Out or Recirculating with Recirculating
Kit sold separately

An island hood with an elegant vertical style, Chrome's design is simple yet sophisticated, with four separate panels of polished stainless steel, forming the sides of the chimney, which convey strength and timeless grace.

Chrome with the EDS3 (Elica Deep Silence) technology, delivers the golden pleasures of silence. With only 4.8 sones at top speed, the kitchen is truly a peaceful place to pass the time in perfect silence.

The powerful 600 CFM blower and LED lighting are operated by a touch sensitive steel rod control, aptly named the Magic Wand. A gentle touch of the finger to the rod is all it takes, or operate from anywhere in the room with the beautifully crafted Jet black remote control.

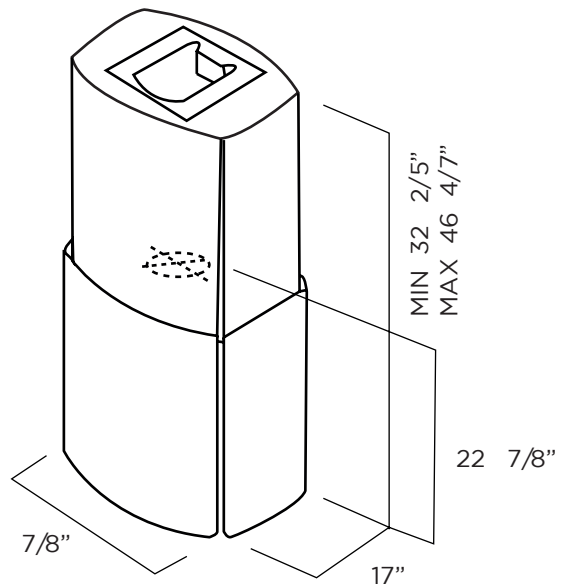

SPECIFICATIONS

Illumination	2 LED Lamps, 2.0 W
Electrical	120 V - 60 Hz 490 Wattage

Controls	Magic Wand
Filter	Dishwasher-Safe Anodized Aluminum Mesh Grease Filter
CFM	600 CFM
Noise (sones) at working speed	.7 - 4.8 sones

KITS AND ACCESSORIES

Optional Recirculating Kit	KIT01916/S
Optional Jet Black Remote Control	KIT02183/1



MODELS

23" CHROME STAINLESS STEEL	ECH623S1
----------------------------	----------



GLIDE

DESIGN FABRIZIO CRISÀ

30" , 36"

Duct Out Or Recirculating with Kit sold separately

The ultra-thin 23/4" Glide brings a sleek understated look to modern kitchens that desire minimalism. The crescent shape profile is uncommon and attractive, while the retractable, curved glass visor helps capture cooking vapors, and empowers the user to operate the blower and lights without reaching for the controls.

Glide comes equipped with a 400 CFM blower, plus reliable electronic push button controls operate 2 LED lights and the 4-speed blower. Easy maintenance and a cleaner kitchen are ensured by a dishwasher safe, stainless steel mesh filter. Glide is designed for standard ducted installations, but can also be installed as a recirculating system.

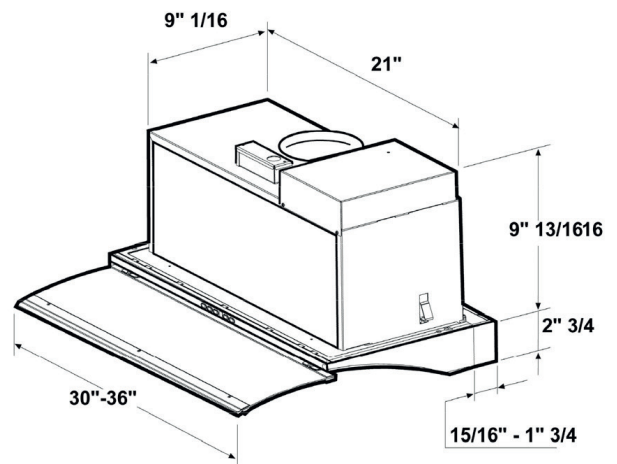

SPECIFICATIONS

Illumination	2 LED Lights
Duct Transition	
Controls	Electronic Push Button
Filter	1 Dishwasher-Safe, Stainless Steel Mesh
CFM	400 CFM
Noise (sones) at working speed	5.2

KITS AND ACCESORIES

Recirculating Kit

F00539



MODELS

GLIDE 30" SS LED	EGL430S1
GLIDE 36" SS LED	EGL436S1
GLIDE 30" SS Halogen	EGL430SS
GLIDE 36" SS Halogen	EGL436SS

ELICA PRO

CERVINIA

ELICA PRO







CERVINIA

ELICA PRO

30" , 36"
Duct Out Only

Available in 30" and 36" widths and only 11 1/32" high, the Cervinia is a streamlined version of the full-size Calabria model. This hood features professional styling, seamless welded corner craftsmanship, a powerful 600 CFM blower with high airflow, heavy duty stainless steel baffle grease filters,

Replaceable LED lighting, plus backlit hidden metallic in/out knobs for convenience and safety. Cervinia also delivers higher efficiency and easy maintenance for a cleaner kitchen.



SPECIFICATIONS

<p>Illumination Electrical</p>	<p>2 LED, 7.5 W 120V - 60 Hz</p>
<p>Controls</p>	<p>Fully retractable rotating knobs with blue backlighting</p>
<p>Filter</p>	<p>2 Dishwasher-Safe, 2 Professional Stainless Steel, Angled Baffle Filter</p>
<p>CFM</p>	<p>600 CFM</p>
<p>Noise (sones) at working speed</p>	<p>Min: 2.34, Max: 7</p>

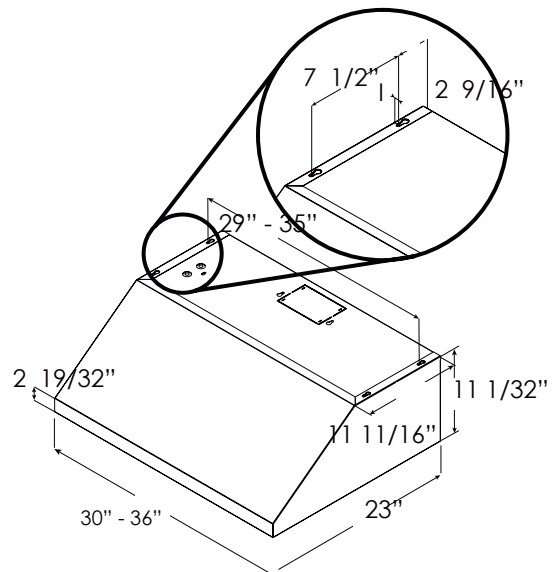

KITS AND ACCESSORIES

<p>Long Chimney Extension Kit 6" for CERVINIA 30"</p>	<p>KIT2159</p>
<p>Long Chimney Extension Kit 6" for CERVINIA 36"</p>	<p>KIT2158</p>
<p>Long Chimney Extension Kit 12" for CERVINIA 30"</p>	<p>KIT2160</p>
<p>Long Chimney Extension Kit 12" for CERVINIA 36"</p>	<p>KIT2161</p>
<p>Back Splash Kit for 30"</p>	<p>KIT0142864</p>
<p>Back Splash Kit for 36"</p>	<p>KIT0142867</p>

MODELS

<p>30" Cervinia Stainless Steel</p>	<p>ECV630S3</p>
<p>36" Cervinia Stainless Steel</p>	<p>ECV636S3</p>



CALABRIA

ELICA PRO

30" , 36" , 42" , 48"

Duct Out Only

For homeowners who are passionate about the culinary arts, the seamless welded corner craftsmanship, traditional styling and gleaming stainless steel of Calabria, provides the look and performance expected from a professional-grade range hood.

With the new backlit hidden knob controls and traditional baffle filters, Calabria is available in 30", 36", 42" and 48" widths and equipped with a 600 CFM (30" and 36") or 1200 CFM blower (36", 42", 48") to support all cooking needs. Designed for standard ducted ventilation only.



SPECIFICATIONS

Illumination
Duct Transition

2 LED Lights

Controls

Electronic Push Button

Filter

1 Dishwasher-Safe, Stainless Steel Mesh

CFM

400 CFM

Noise (sones) at working speed

5.2

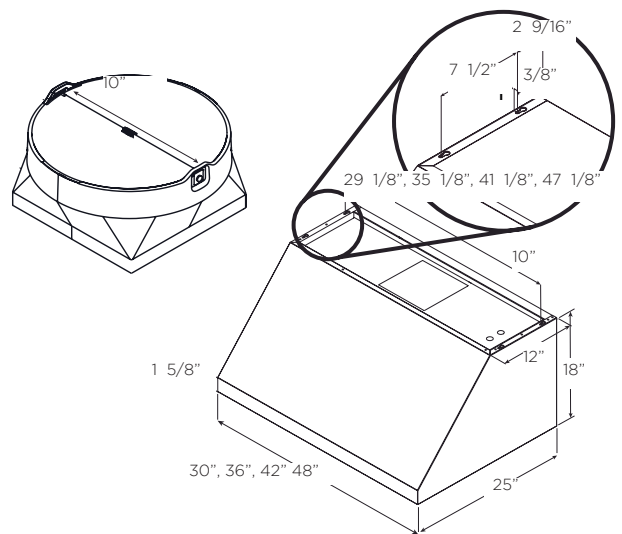

KITS AND ACCESSORIES

Recirculating Kit

F00539

MODELS

GLIDE 30" SS LED
GLIDE 36" SS LED
GLIDE 30" SS Halogen
GLIDE 36" SS Halogen

EGL430S1
EGL436S1
EGL430SS
EGL436SS



LEONE

ELICA PRO

30", 36", 42", 48"
Duct Out Only

Give a splash of Italian design to your professional kitchen with Leone's crisp lines, seamless welded corner craftsmanship, beveled rim and gleaming stainless steel. Leone has the extra depth (24") and power (1200 CFM on 36", 42" & 48" W) & 36" in 600 CFM needed to support professional ranges and cooktops. No ear plugs required with Leone's HUSH sound suppression system, which enables you to comfortably talk and entertain, even when cooking up a storm. Available in 30", 36" and 42" widths, Leone features backlit hidden knob controls, which operate the 4-speed blower and LED lighting. Designed for standard ducted ventilation only.



SPECIFICATIONS

Illumination	2 LED, 7.5 Watts
Electrical	120V - 60 Hz
Controls	Fully retractable rotating knobs with blue backlighting
Filter	Dishwasher-Safe, Professional Stainless Steel, Angled Baffled Filters
CFM	600/1200 CFM
Noise (sones) at working speed	Min: 3.21, Max: 7.7

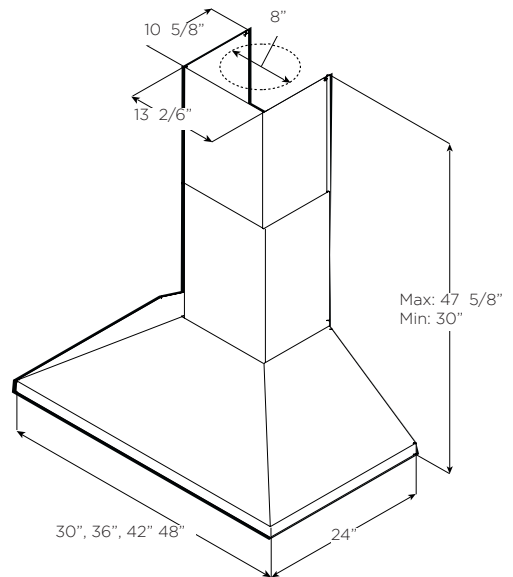

KITS AND ACCESSORIES

Long Chimney Extension Kit 13' for LEONE	KIT02785
Long Chimney Extension Kit 11' 4" for LEONE	KIT01935
1200 CFM External Blower	KIT0153054
1200 CFM In Line Blower	KIT0154387

MODELS

Leone 30" SS	ELN630S1 / ELN630S2
Leone 42" SS	ELN142S1 / ELN142S2



LEONE ISLAND

ELICA PRO

36" , 42"
Duct Out Only

Designed to be suspended above a kitchen island, Leone's crisp lines, beveled rim and gleaming stainless steel deliver professional cooking with a sense of style. Give your kitchen a splash of Italian design with a chimney style island hood that has the extra depth and power required to support professional ranges and cooktops. Available in 36" and 42" widths, Leone Island comes equipped with an extra powerful 1200 CFM internal blower and backlit hidden metallic in/out knobs, which operate the 4 speed blower and LED lighting



SPECIFICATIONS

Illumination 4 LED, 7.5 W LED light
Electrical 120V - 60 Hz

Controls Fully retractable rotating knobs with blue backlighting
Filter Dishwasher-Safe, Professional Stainless Steel, 2 Angled Baffle Filter
CFM 1200 CFM
Noise (sones) at working speed Min: 3.21, Max: 7.7

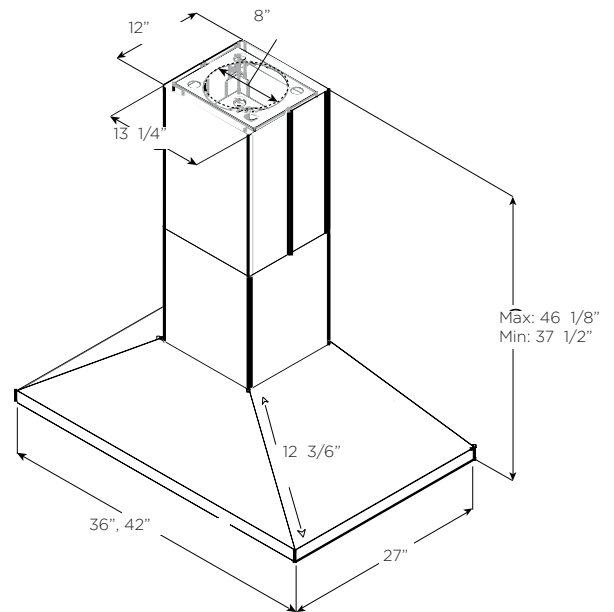

KITS AND ACCESSORIES

Long Chimney Extension Kit for LEONE ISLAND KIT0100317

MODELS

Leone Island 36" Unit ELI136S2
Leone Island 42" Unit ELI142S2

VAVANO

ELICA PRO







VAVANO

ELICA PRO

36", 48"
Duct Out Only

Give a splash of Italian design to your professional kitchen with Vavano's crisp lines, seamless welded corner craftsmanship, beveled rim and gleaming stainless steel. No ear plugs required with Vavano's HUSH sound suppression system, which enables you to comfortably talk and entertain, even when cooking up a storm. Available in 36" and 48" widths, Vavano features backlit hidden knob controls, which operate the 4-speed blower and LED lighting. Easy maintenance and cleaner kitchen are assured with professional stainless steel angled baffle filters.

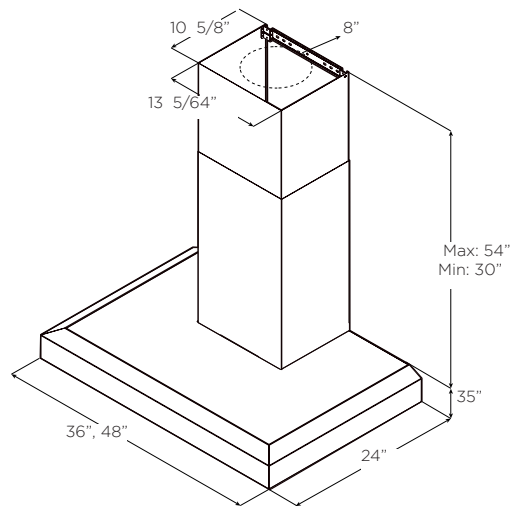

SPECIFICATIONS

Illumination	2 LED, 7.5 Watts
Electrical	120V - 60 Hz
Controls	Fully retractable rotating knobs with blue backlighting
Filter	Dishwasher-Safe, Professional Stainless Steel,
CFM	600/1200 CFM
Noise (sones) at working speed	Min: 3.21, Max: 7.7

KITS AND ACCESSORIES

Long Chimney Extension Kit 12"	KIT0146881
In-line Blower Kit (1200 CFM)	KIT0154387
External Blower Kit	KIT0153054

MODELS

Vavano 36" unit	EVV636S1
Vavano 48" unit	EVV648S1



VAVANO ISLAND

ELICA PRO

42", 48"
Duct Out Only

Designed to be suspended above a kitchen island, Vavano's crisp lines, beveled rim and gleaming stainless steel deliver professional cooking with a sense of style. Give your kitchen a splash of Italian design with a box style island hood that has the extra depth and power required to support professional ranges and cooktops. Available in 42" and 48" widths, Vavano Island comes equipped with a powerful 600 CFM internal blower and backlit hidden metallic in/out knobs, which operate the 4 speed blower and LED lighting.

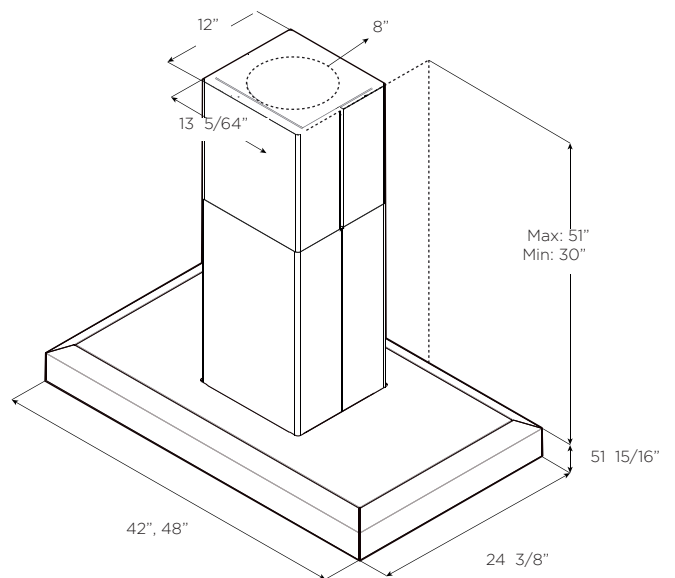

SPECIFICATIONS

<p>Illumination</p> <p>Electrical</p>	<p>4 LED, 7.5 Watts</p> <p>120V - 60 Hz</p>
<p>Controls</p>	<p>Fully retractable rotating knobs with blue backlighting</p>
<p>Filter</p>	<p>3 Dishwasher-Safe, Professional Stainless Steel, 3 Angled Baffle Filters</p>
<p>CFM</p>	<p>600/1200 CFM</p>
<p>Noise (sones) at working speed</p>	<p>Min: 3.21, Max: 7.7</p>

KITS AND ACCESSORIES

<p>Long Chimney Extension Kit 12"</p>	<p>KIT0145610</p>
<p>In-line Blower Kit (1200 CFM)</p>	<p>KIT0154387</p>
<p>External Blower Kit</p>	<p>KIT0153054</p>

MODELS

<p>Vavano 42" unit</p>	<p>EVI642S1</p>
<p>Vavano 48" unit</p>	<p>EVI648S1</p>



AREZZO

ELICA PRO

28", 34", 40", 46"
Duct Out Only

Arezzo provides professional grade performance, while being discreetly mounted inside the cabinetry. Available in 28 1/2" and 34" width with a 600 CFM blower, and equipped with a 1200 CFM blower for widths of 34 1/2", 40 1/2" and 46 1/2" for extraordinary ventilating power. The extra depth (22") is ideal for supporting powerful professional ranges. Plus the All-In-One design avoids the need to purchase a stainless liner. Hidden metallic in/out knob controls operate the 4-speed blower and LED lighting.

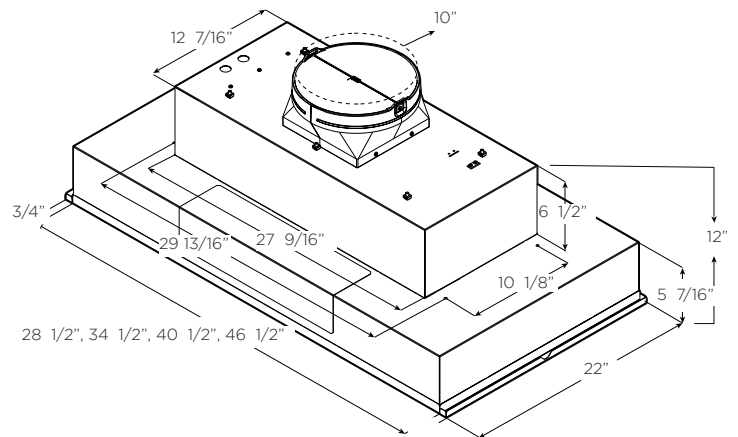

SPECIFICATIONS

Illumination	2 LED, 7.5 Watts
Electrical	120V - 60 Hz
Controls	Fully retractable rotating knobs with blue backlighting
Filter	Dishwasher-Safe, Professional Stainless Steel Baffle Filter
CFM	600/1200 CFM
Noise (sones) at working speed	Min: 2.05, Max: 7.5

KITS AND ACCESSORIES

In-line Blower Kit 1200	KIT0154387
External Blower Kit 1200	KIT0153054

MODELS

Arezzo 28" Unit	EAR628S4
Arezzo 34" Unit	EAR634SS (600 CFM) EAR134S4 (1200 CFM)
Arezzo 40" Unit	EAR140S4
Arezzo 46" Unit	EAR146S4



TRENTO

ELICA PRO

34" SS (600 or 1200) CFM
Duct Out Only

Trento provides professional grade performance, while being discreetly mounted inside the cabinetry. It is available with a 600 CFM or 1200 CFM blower for extraordinary ventilating power. Plus the All-In-One design avoids the need to purchase a stainless liner. Hidden metallic in/out knob controls operate the 4-speed blower and LED lighting. A cleaner kitchen is ensured by Elica's patented angled baffle filters, which capture a higher percentage of contaminants and hold larger volumes of grease than traditional baffle filters.

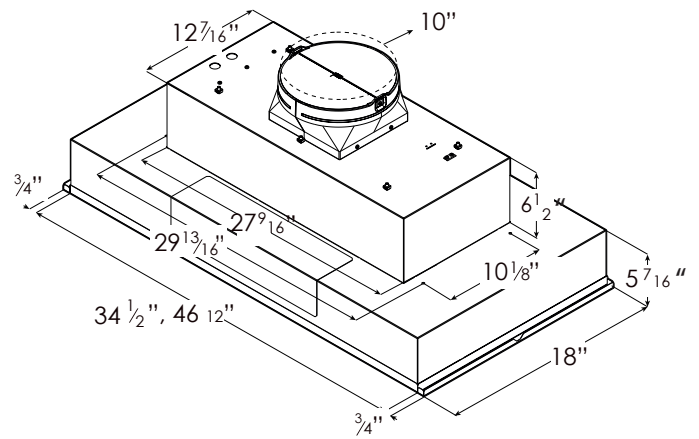

SPECIFICATIONS

Illumination	2 LED, 7.5 Watts
Electrical	120V - 60 Hz
Controls	Fully retractable rotating knobs with blue backlighting
Filter	Dishwasher-Safe, Professional Stainless Steel
CFM	1200 CFM
Noise (sones) at working speed	Min: 2.05, Max: 7.5

KITS AND ACCESORIES

In-line Blower Kit 1200	KIT0154387
External Blower Kit 1200	KIT0153054

MODELS

TRENTO 34" Unit (600 CFM)	ETR634SS
TRENTO 34" Unit (1200 CFM)	ETR134S1
TRENTO 46" Unit (1200 CFM)	ETR146SS



CAPRI
ELICA PRO



CAPRI

ELICA PRO

36" 48"
Duct Out Only

Tame the outdoors, without sacrificing style and luxury. Capri features a heavy gauge, corrosion resistant 302-grade stainless steel body, which will withstand the harshest environment. The extra deep 32" hood body is complimented with dual sets of angled stainless steel professional baffle filters, that provide exceptional air capture and a 1200 CFM blower has the power to do the job. Capri is available in 36" and 48" widths, an optional 3" spacer will extend the depth to 35" for added capture efficiency, plus optional 12" and 6" duct covers are available to reach any ceiling height.

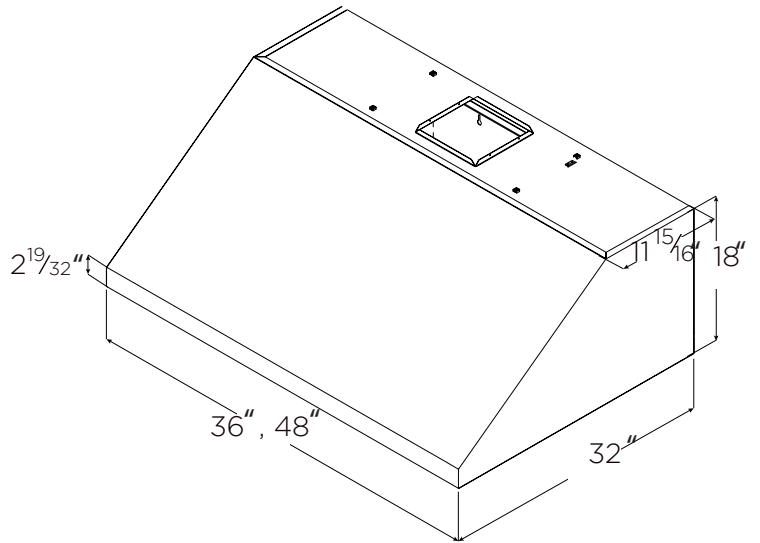

SPECIFICATIONS

Illumination	2 LED, 7.5 Watts
Electrical	120V - 60 Hz
Controls	Fully retractable rotating knobs with blue backlighting
Filter	Dishwasher-Safe, Professional Stainless Steel
CFM	1200 CFM
Noise (sones) at working speed	Min: 2.47, Max: 9.04

KITS AND ACCESORIES

External Blower Kit 1200 CFM	KIT0153054
In- Line Blower Kit 1200 CFM	KIT0154387
1200 CFM Internal Blower	KIT0156655

MODELS

CAPRI 34" Unit	ECP136SS
CAPRI 48" Unit (1200 CFM)	ECP148SS

TECHNE

STONE

TECHNE







STONEY

TECHNE

30", 36"

Ducted or Recirculating with Recirculating Kit (sold separately)

The pairing of glass and brilliant stainless steel, make it ideal for any kitchen. Perimeter Aspiration technology helps to achieve Top Performance by delivering more powerful and efficient fume extraction, plus it reduces noise. Available in 30" & 36" widths, Stoney includes a powerful 600 CFM blower, LED lighting with dimmable feature and glass capacitive touch controls. Stoney is meant for anyone who loves high- technological solutions, where Elica hoods and cooktops automatically communicate, recognizing quality and quantity of cooking vapors, thus accordingly adjusting performance levels.



SPECIFICATIONS

Illumination	2 LED Premium Dimmable Lights 2.5 WATTS
Electrical	120V - 60 Hz 460 Watt at 3.7 Amp
Controls	Touch Control 3 Speeds + Booster
Filter	Dishwasher safe, Aluminum Mesh Filter + Perimeter Aspiration
CFM	600 CFM
Noise (sones) at working speed	Min 1.53 Max 6

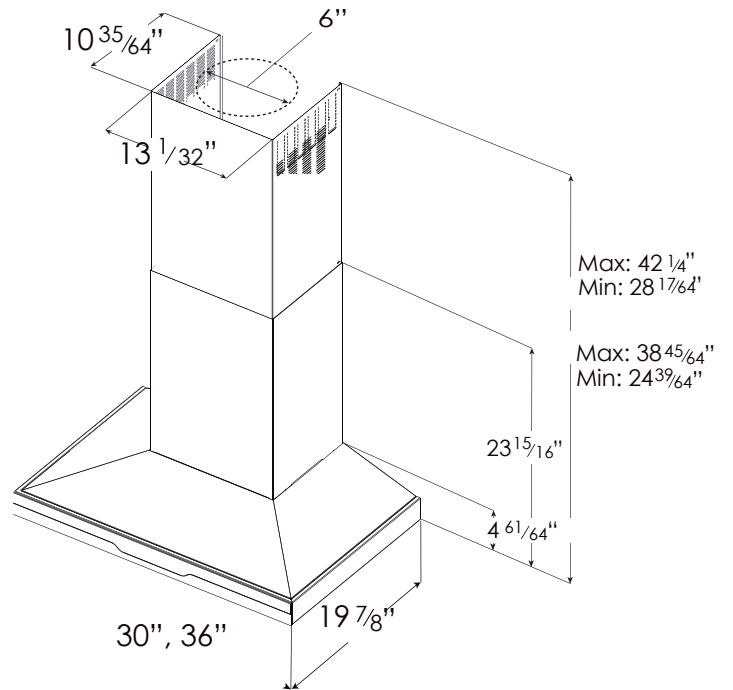

KITS AND ACCESORIES

Recirculating Kit	KIT0141925
Long Chimney Extension	KIT02785
Charcoal Filter Replacement:	KIT0141918

MODELS

STONEY 30" Unit	EST630SS
STONEY 36" Unit	EST636SS



STONEY ISLAND

TECHNE

36", 42"

Ducted or Recirculating with Recirculating Kit (sold separately)

The pairing of glass and brilliant stainless steel, make it ideal for any kitchen with island blending perfectly with other appliances. Perimeter Aspiration technology helps to achieve Top Performance by delivering more powerful and efficient fume extraction, plus it reduces noise.

Available in 36" & 42" widths, Stoney Island includes a powerful 600 CFM blower, LED lighting with dimmable feature and glass capacitive touch controls. Stoney Island is meant for anyone who loves high-technological solutions, where Elica hoods and cooktops automatically communicate, recognizing quality and quantity of cooking vapors, thus accordingly adjusting performance levels.



SPECIFICATIONS

Illumination	4 Premium LED Dimmable Lights 2.5 WATTS
Electrical	120 V - 60 Hz 460 Watt at 3.7 Amp
Controls	Touch Control 3 Speeds + Booster (sensor)
Filter	Dishwasher safe, Aluminum Mesh Filter + Perimeter Aspiration
CFM	600 CFM
Noise (sones) at working speed	Min 1.46 Max 6

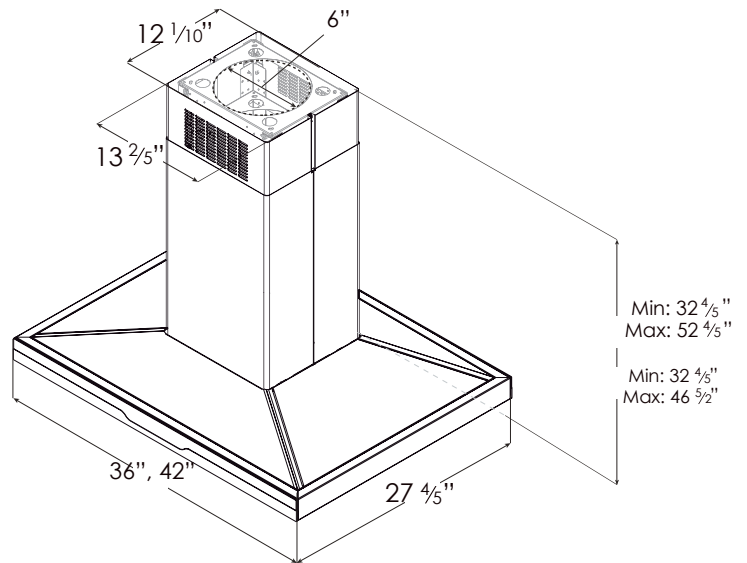

KITS AND ACCESSORIES

Recirculating Kit	KIT0141924
Long Chimney Extension	KIT0100317
Charcoal Filter Replacement:	KIT0141918

MODELS

STONEY 30" Unit	ESI636SS
STONEY 42" Unit	ESI642SS

COMO

TECHNE



ca





COMO

TECHNE

30", 36"

Ducted or Recirculating with Recirculating Kit (sold separately)

Como combines arched glass wings and stainless steel to create a light and airy environment... the perfect centerpiece for any contemporary kitchen.

This gently flowing design is powered by a 600 CFM blower that can handle the demands generated by today's cooktops. Como is equipped with glass touch controls, LED dimmable lighting and dishwasher-safe stainless steel microhole filter.

Designed for standard ducted installation, Como can also be installed as a recirculating system using the Recirculating Kit, available as an accessory



SPECIFICATIONS

Illumination	2 Premium LED Dimmable Lights
Electrical	120V - 60 Hz 394 Watt at 3.27 Amp
Controls	Touch Control 3 Speeds + Booster
Filter	Dishwasher- Safe, Stainless Steel Microhole Filter
CFM	600 CFM
Noise (sones) at working speed	Min 2.36 Max 6

KITS AND ACCESSORIES

Optional Recirculating Kit	KIT02721
Optional Long Chimney Extension	KIT0100315
Recirculating Long Life Filter	KIT02199
Charcoal Filter Replacement	KIT02667

MODELS

COMO 30" Unit	ECM630S3
COMO 36" Unit	ECM636S3

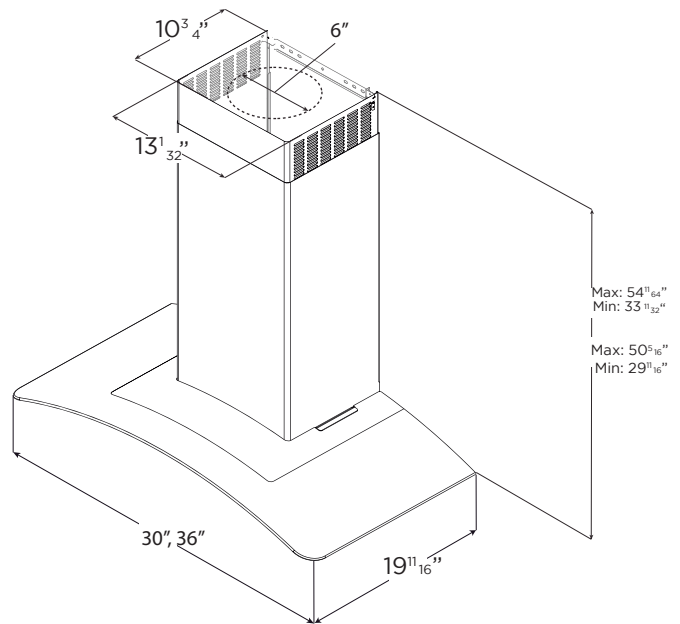



CINGOLI

TECHNE

36", 42"

Ducted or Recirculating with Recirculating Kit (sold separately)

Designed to be suspended above a kitchen island, Cingoli takes flight with graceful 36" or 42" arched glass wings, which allow natural light to illuminate the surface below. The expansive glass wings are complemented by reflective stainless steel. The beauty of Cingoli is combined with features such as a powerful 600 CFM blower, dishwasher-safe stainless steel microhole filter and glass touch controls that deliver convenience and safety.

Designed for standard ducted installation, Cingoli can also be installed as a recirculating system using the Recirculating Kit, available as an accessory



SPECIFICATIONS

Illumination	2 Premium LED Dimmable Lights
Electrical	120V - 60 Hz 394 Watt at 3.27 Amp
Controls	Touch Control 3 Speeds + Booster
Filter	2 Dishwasher-Safe, Stainless Steel Baffle Slot Filters
CFM	600 CFM
Noise (sones) at working speed	Min 2.36 Max 6

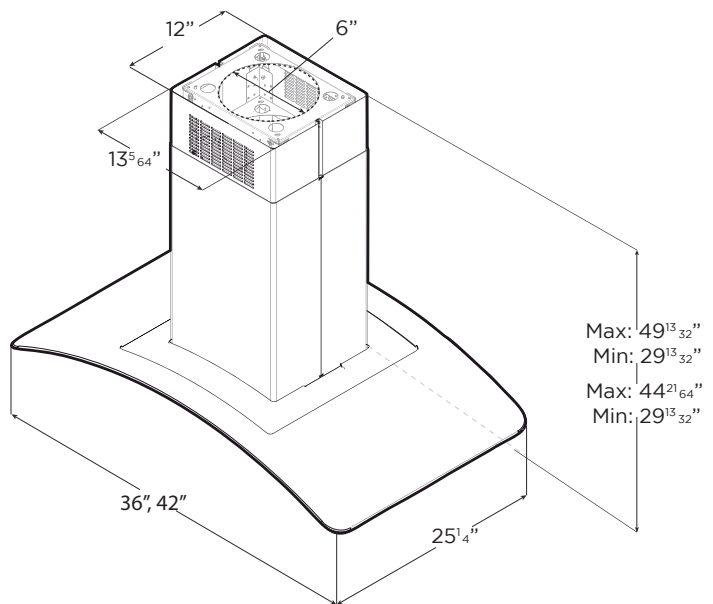

KITS AND ACCESSORIES

Optional Recirculating Kit	KIT02665
Optional Long Chimney Extension	KIT0100317
Recirculating Long Life Filter	KIT02198
Charcoal Filter Replacement	KIT02667

MODELS

CINGOLI 36" Unit	ECN636S3
CINGOLI 42" Unit	ECN642S3



LUGANO

TECHNE

30", 36"

Ducted or Recirculating with Recirculating Kit (sold separately)

The pairing of glass and brilliant stainless steel, make it ideal for any kitchen and will blend perfectly with other appliances. Perimeter Aspiration technology helps to achieve Top Performance by delivering more powerful and efficient fume extraction, plus it reduces noise. Available in 30" & 36" widths, Lugano includes a powerful 600 CFM blower, LED lighting with dimmable feature and glass capacitive touch controls.

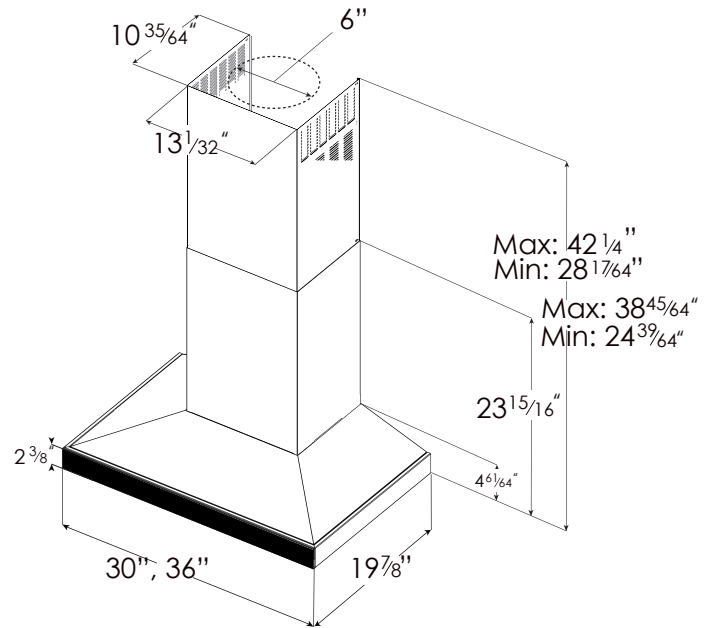

SPECIFICATIONS

Illumination	2 LED Premium Dimmable Lights, 2.5 w
Electrical	120V - 60 Hz 450 Watt at 3.7 Amp
Controls	Touch Control 3 Speeds + Booster
Filter	Aluminum Mesh Filter + Perimeter Aspiration
CFM	600 CFM
Noise (sones) at working speed	Min 2.03 Max 8

KITS AND ACCESSORIES

Recirculating Kit	KIT0141925
Long Chimney Extension	KIT02785
Recirculating Long Life Filter	KIT02199
Charcoal Filter Replacement	KIT0141918

MODELS

LUANO 30" Unit	ELG630S3
LUANO 36" Unit	ELG636S3



SALICE ISLAND

TECHNE

36", 42"

Ducted or Recirculating with Recirculating Kit (sold separately)

Salice conveys understated elegance with a gently tapered canopy that measures only 5" tall, which opens up the kitchen for entertainment and conversation. Available in 36" and 42" widths, Salice features a powerful 600 CFM blower, LED Dimmable lighting, perimeter aspiration and high-tech glass touch controls that deliver convenience and safety.

Designed for ducted installation, Salice can also be installed as a recirculating system using the Recirculating Kit, available as an accessory.

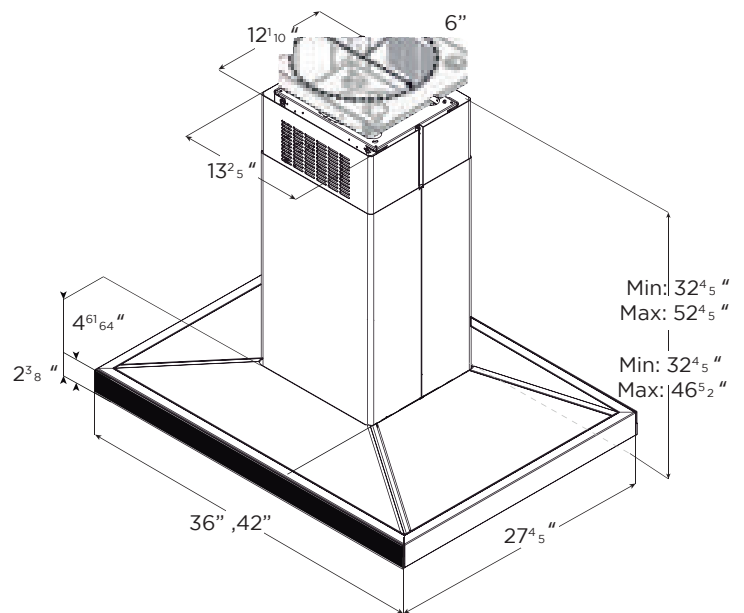

SPECIFICATIONS

Illumination	4 Premium LED Dimmable Lights
Electrical	120V - 60 Hz 460 Watt at 3.7 Amp
Controls	Touch Control 3 Speeds + Booster
Filter	Aluminum Mesh Filter + Perimeter Aspiration
CFM	600 CFM
Noise (sones) at working speed	Min 1.73 Max 6

KITS AND ACCESORIES

Recirculating Kit	KIT0141924
Long Chimney Extension	KIT0100317
Characoal Filter Replacement	KIT0141918

MODELS

SALICE 36" Unit	ESL636S3
SALICE 42" Unit	ESL642S3

MAGGIORE

TECHNE







MEZZANO

TECHNE

30", 36"

Ducted or Recirculating with Recirculating Kit (sold separately)

With a minimalist design but a strong stainless steel construction, Mezzano is in tune with avant-garde appliances where clear and architectural lines take precedence. Mezzano has a powerful 600 CFM blower, LED dimmable, stainless steel microhole filters and high-tech multi-function touch controls that deliver convenience and safety. Mezzano was designed for standard ducted installation, but with also can be installed using the Recirculating Kit, available as an accessory.

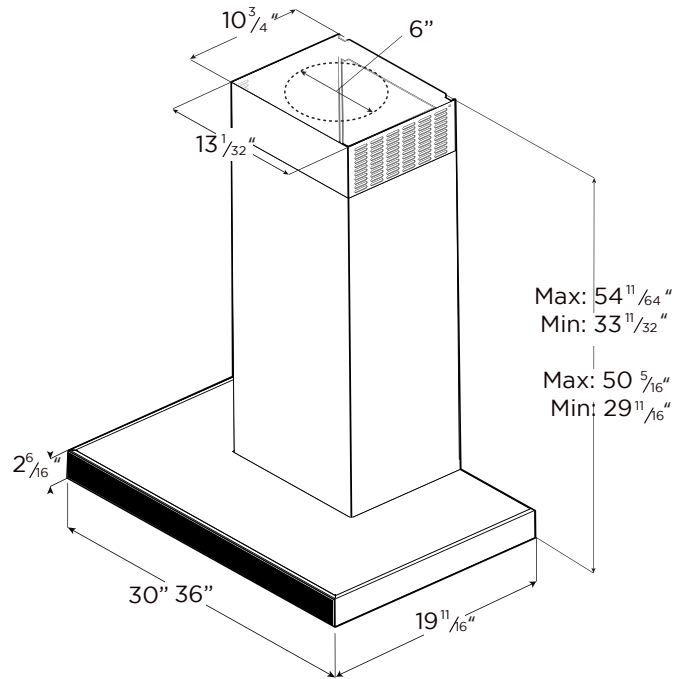

SPECIFICATIONS

Illumination	2 LED Premium Dimmable Lights, 2.5 w
Electrical	120V - 60 Hz 455 Watt at 3.8 Amp
Controls	Touch Control 3 Speeds + Booster
Filter	Dishwasher- Safe, Staineless Steel Microhole Filter (2 w/30", 3 w/36")
CFM	600 CFM
Noise (sones) at working speed	Min 1.73 Max 6

KITS AND ACCESSORIES

Recirculating Kit	KIT0102875
Long Chimney Extension	KIT02785
Recirculating Long Life Filter	KIT02199

MODELS

MEZZANO 30" Unit	EMZ630S3
MEZZANO 36" Unit	EMZ636S3



MAGGIORE ISLAND

TECHNE

36", 42"

Ducted or Recirculating with Recirculating Kit (sold separately)

With a minimalist design but a strong stainless steel construction, Maggiore is in tune with avant-garde appliances where clear and architectural lines take precedence. Maggiore has a powerful 600 CFM blower, LED dimmable lights, stainless steel microhole filters and high-tech glass touch controls that deliver convenience and safety.

Maggiore was designed for standard ducted installation, but with also can be installed using the Recirculating Kit, available as an accessory.

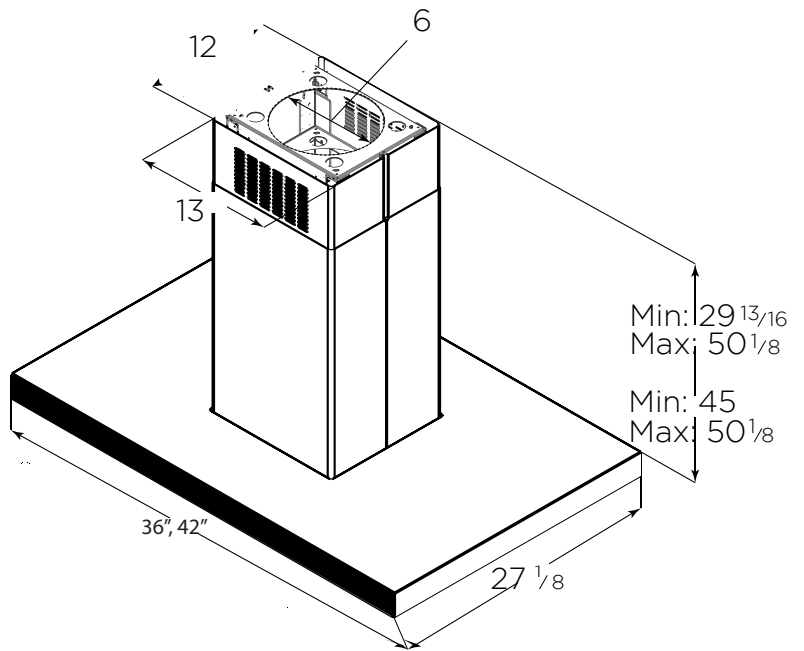

SPECIFICATIONS

Illumination	4 LED Premium Dimmable Lights, 2.5 w
Electrical	120V - 60 Hz 426.2 Watt at 3.55 Amp
Controls	Touch Control 3 Speeds + Booster
Filter	Dishwasher- Safe, Staineless Steel Microhole Filter
CFM	600 CFM
Noise (sones) at working speed	Min 1.73 Max 6

KITS AND ACCESSORIES

Recirculating Kit	KIT02665
Long Chimney Extension	KIT0100317
Charcoal Filter	KIT02667

MODELS

MAGGIORE 36" Unit	EMG636S1
MAGGIORE 42" Unit	EMG642S1



VARNA
TECHNE



VARNA

TECHNE

30", 36"

Ducted or Recirculating with Recirculating Kit (sold separately)

The clean lines, beautiful sloping angles and stainless steel finish of Varna make a striking visual statement. Available in 30" or 36" width, Varna features include a powerful 600 CFM blower, LED dimmable lighting, dishwasher-safe stainless steel microhole filter, and easy to use glass capacitive touch controls that deliver convenience and safety. Designed for standard ducted installation, Varna can also be installed with recirculating system using the kit available as an accessory.

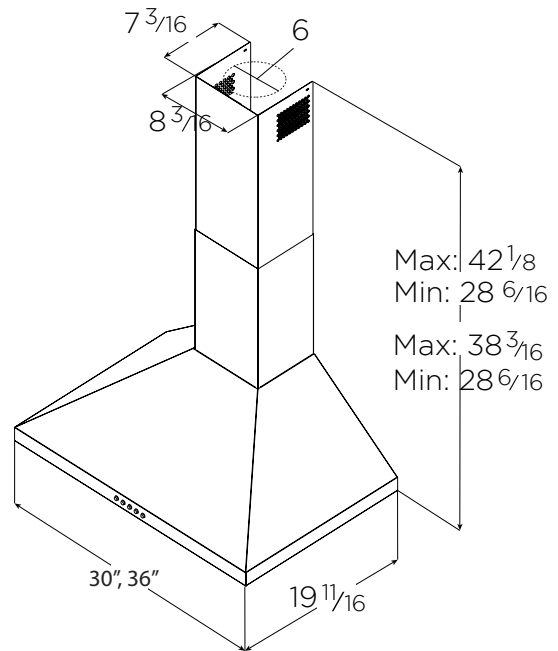

SPECIFICATIONS

Illumination	2 LED Premium Dimmable Lights, 2.5 w
Electrical	120V - 60 Hz 265 Watt at 2 Amp
Controls	Touch Control 3 Speeds + Booster
Filter	Dishwasher-Safe, Stainless Steel Microhole Filter
CFM	600 CFM
Noise (sones) at working speed	Min 1.93 Max 6

KITS AND ACCESORIES

Recirculating Kit	KIT02766
Long Chimney Extension	KIT02762

MODELS

VARNA 30" Unit	EVR630S2
VARNA 36" Unit	EVR636S2
VARNA BLACK 30" Unit	EVR630BL
VARNA BLACK 36" Unit	EVR630BL





FOGLIA
TECHNE



FOGLIA

TECHNE

30", 36"

Ducted or Recirculating with Recirculating Kit (sold separately)

Black panel and polished stainless steel, Foglia features a gently arched front that softens the units profile and provides an angled panel for easy access to the controls.

Available in 30" & 36" widths, Foglia includes a powerful 600 CFM blower, LED lighting with dimmable feature, stainless steel microhole filters and capacitive touch controls that deliver convenience and safety.

Designed for standard ducted installation, Foglia can also be installed as a recirculating system using the Recirculating Kit, available as an accessory



SPECIFICATIONS

Illumination	2 LED Premium Dimmable Lights, 2.5 w
Electrical	120V - 60 Hz 455 Watt at 3.8 Amp
Controls	Touch Control 3 Speeds + Booster
Filter	Dishwasher-Safe, Stainless Steel Microhole Filter
CFM	600 CFM
Noise (sones) at working speed	Min 1.71 Max 7.5

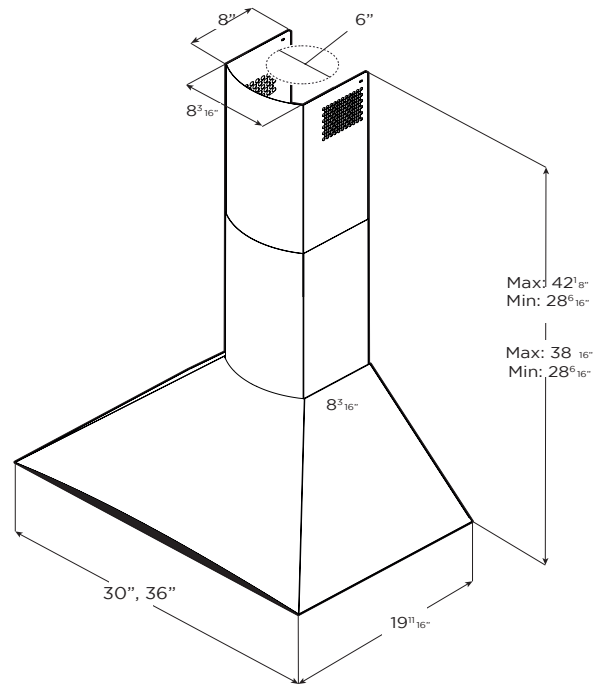

KITS AND ACCESSORIES

Optional Recirculating Kit	KIT02766
Chimney Extension	KIT02784

MODELS

FOGLIA 30" Unit	EFG630S1
FOGLIA 36" Unit	EFG636S1



PILATO

TECHNE

30", 36"

Ducted or Recirculating with Recirculating Kit (sold separately)

The rounded front, beautifully sloping angles and stainless steel finish of Pilato make a striking visual statement. Available in 30" or 36" widths, Pilato features include a powerful 600 CFM blower, 2 LED lights, dishwasher safe stainless steel microhole filters and multi-function electronic controls with LCD display that deliver convenience and safety. Designed for standard ducted installation, Pilato can also be installed as a recirculating system using the Recirculating Kit, available as an accessory

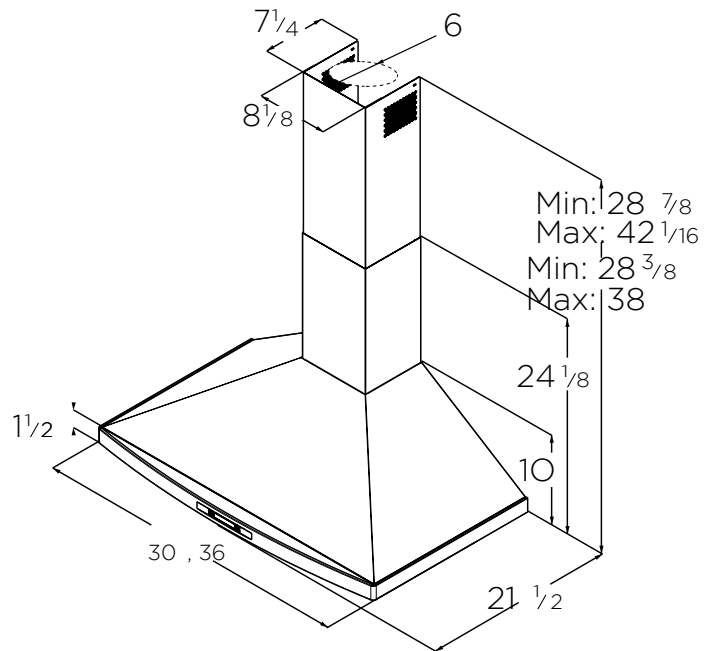

SPECIFICATIONS

Illumination	2 LED Lights, 2.5 w
Electrical	120V - 60 Hz 450 Watt at 3.7 Amp
Controls	Touch Control 3 Speeds + Booster
Filter	Dishwasher-Safe, Stainless Steel Microhole Filter
CFM	600 CFM
Noise (sones) at working speed	Min 1.7 Max 8.2

KITS AND ACCESSORIES

Recirculating Kit	KIT02766
Chimney Extension	KIT02762

MODELS

PILATO 30" Unit	EPL630S2
PILATO 36" Unit	EPL636S2



ARIA

TECHNE

30", 36"

Ducted or Recirculating with Recirculating Kit (sold separately)

With a compact 3/4" height, Aria is an ideal choice where under-cabinet space is limited. Its upgraded 430 CFM internal blower provides sufficient ventilating power for most kitchens. Aria also offers the luxury and convenience of LED dimmable lighting with 2 Baffle Slot filters and glass touch controls.

Available in 30" or 36" width, Aria is designed for standard ducted installation and can also be used as a recirculating system using the kit available as an accessory.

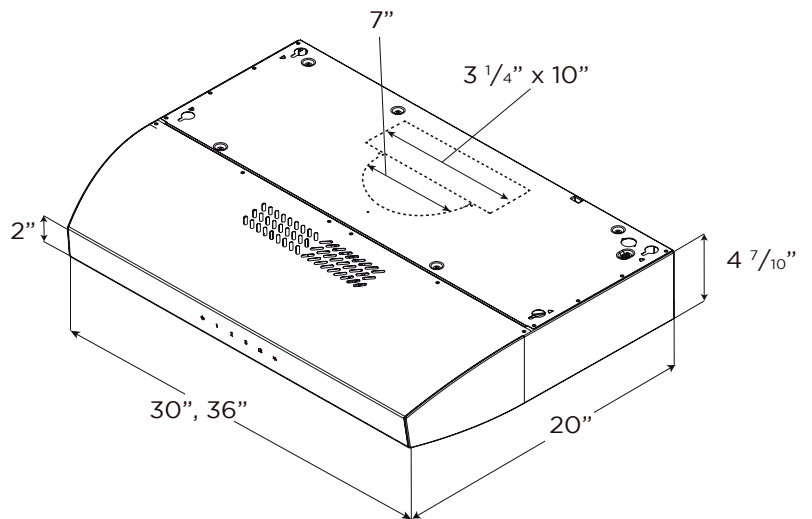

SPECIFICATIONS

Illumination	2 LED Premium Dimmable Lights, 2.5 w
Electrical	120V - 60 Hz 455 Watt at 3.6 Amp
Controls	Touch Control 3 Speeds + Booster
Filter	2 Dishwasher-Safe, Stainless Steel Baffle Slot Filters
CFM	400 CFM
Noise (sones) at working speed	Min 1 Max 4.7

KITS AND ACCESSORIES

Optional Recirculating Kit	KIT02178 / KIT02179
Optional Stainless Steel Mesh	KIT02591 / KIT02592
Optional Backdraft Damper	KIT02723

MODELS

ARIA 30" Unit	EAI430SS
ARIA 36" Unit	EAI436SS



MODENA

TECHNE

30", 36"

Ducted or Recirculating with Recirculating Kit (sold separately)

Modena offers a classic designer chimney appearance for under-cabinet installations, with a striking 9" high pyramid shape. Modena also provides high-end features not commonly found in under-cabinet hoods, including 520 CFM blower, LED dimmable lighting, stainless steel microhole filters and easy to use glass capacitive touch controls that deliver convenience and safety.

Available in 30" or 36" width, and designed for standard ducted installation, Modena can also be installed as a recirculating system using the kit available as an accessory. For design versatility to suit almost any kitchen.

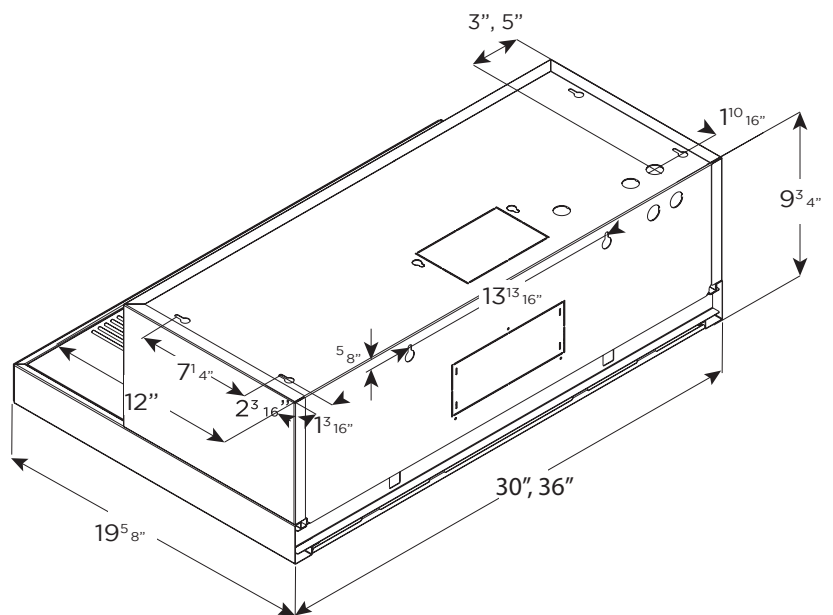

SPECIFICATIONS

Illumination	2 LED Premium Dimmable Lights, 2.5 w
Electrical	120V - 60 Hz 455 Watt at 3.8 Amp
Controls	Touch Control 3 Speeds + Booster
Filter	2 Dishwasher- Safe, Stainless Steel Microhole Filter
CFM	520 CFM
Noise (sones) at working speed	Min 1.73 Max 6

KITS AND ACCESSORIES

Optional Recirculating Kit	KIT02667
----------------------------	----------

MODELS

MODENA 30" Unit	EMD530S3
MODENA 36" Unit	EMD536S3

PALERMO

TECHNE







PALERMO

TECHNE

28"
Ducted or Recirculating with Recirculating Kit
(sold separately)

Palermo provides professional grade performance, while it's 28 1/4" width and 10 3/4" depth enables it to be discreetly installed within standard 12" deep cabinetry, making it ideal for smaller kitchens or where the range hood needs to be out of sight. Palermo has a powerful 600 CFM blower to support most cooking needs. Stylish stainless steel push button controls operate a 3-speed blower and LED lighting.

Easy maintenance, higher efficiency and a cleaner kitchen are ensured by Elica's Baffle Slot Filters, which capture a higher percentage of grease and hold larger volumes of grease than traditional baffle filters. Palermo is designed for standard ducted or recirculating installation.

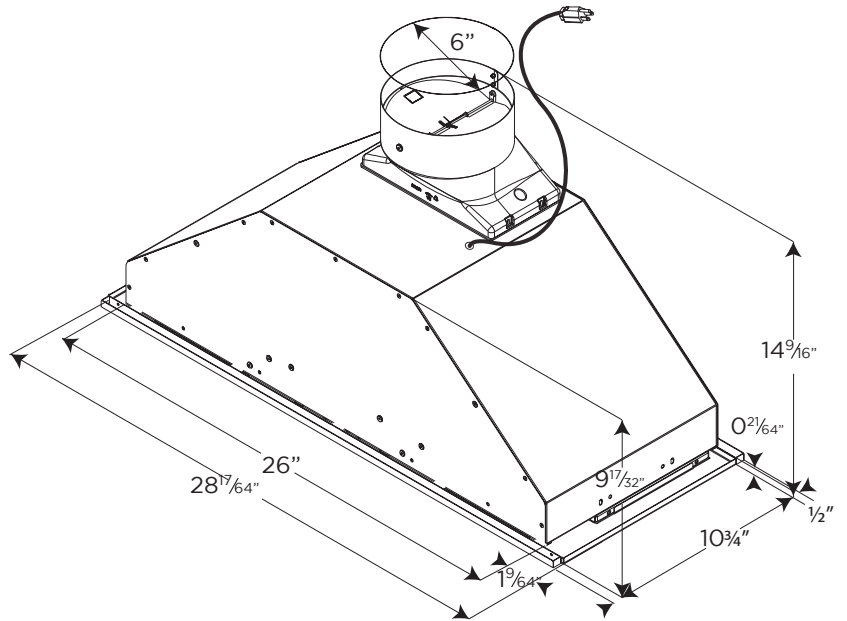

SPECIFICATIONS

Illumination	2 LED Premium Dimmable Lights, 2.5 w
Electrical	120V - 60 Hz 455 Watt at 3.8 Amp
Controls	Stainless Steel Push Button
Filter	2 Dishwasher-Safe, Stainless Steel Baffle Slot
CFM	600 CFM
Noise (sones) at working speed	Min 2.1 Max 6

KITS AND ACCESSORIES

Optional Recirculating Kit	KIT02770
Optional 30" Hood Liner	KIT02773
Optional 36" Hood Liner	KIT02774

MODELS

PALERMO 28" Unit	EPR628S1
------------------	----------



BELLAGIO

TECHNE

30", 36"

Ducted or Recirculating with Recirculating Kit (sold separately)

With a compact 4 3/4" height, Bellagio is an ideal choice where under-cabinet space is limited. An upgraded 4-speed, 430 CFM internal blower provides sufficient ventilation power for most kitchens. Bellagio also offers convenient LED Lights, dishwasher-safe, anodized aluminum mesh filters and multi-function electronic controls with LCD display.

Available in 30" or 36" width, Bellagio is designed for standard ducted installation, and can also be installed as a recirculating system using the Recirculating Kit, available as an accessory

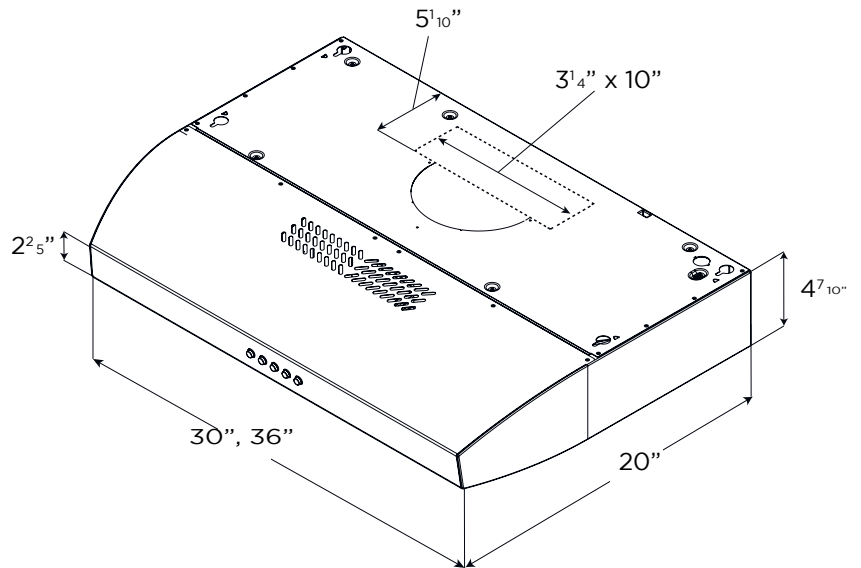

SPECIFICATIONS

Illumination	2 LED Lights
Electrical	120V - 60 Hz 455 Watt at 3.6 Amp
Controls	Multi-function electronic with LCD display
Filter	2, Dishwasher-Safe, Anodized Aluminum Mesh
CFM	400 CFM
Noise (sones) at working speed	Min 1.4 Max 7.1

KITS AND ACCESSORIES

Optional Recirculating Kit	KIT02178 / KIT02179
Optional Stainless Steel Mesh	GRI0131086A / GRI0131087A
Optional Backdraft Damper,	KIT02723

MODELS

BELLAGIO 30" Unit	EBL430S1
BELLAGIO 36" Unit	EBL436S1





RISE

TECHNE

30", 36"

Ducted Installation only

When the view out your kitchen window is too spectacular to disrupt with a range hood, Elica's Rise is the perfect solution.

Rise recesses completely out-of-sight into the countertop (when not in use), but when it's time to cook, Rise elevates a full 14" above the countertop (almost twice the height of competitors), for added ventilating efficiency. On top of that, Elica added Perimeter Aspiration Technology, which increases suction 35% and actually draws air from the front burner effectively, to create the best functioning downdraft on the market. Rise comes equipped with a powerful 600 CFM internal blower, which is operated by an electronic rotating control that's ush mounted into the countertop or cabinet face. For maximum flexibility, the blower can be rotated to the opposite side to make room for a floor mounted range.

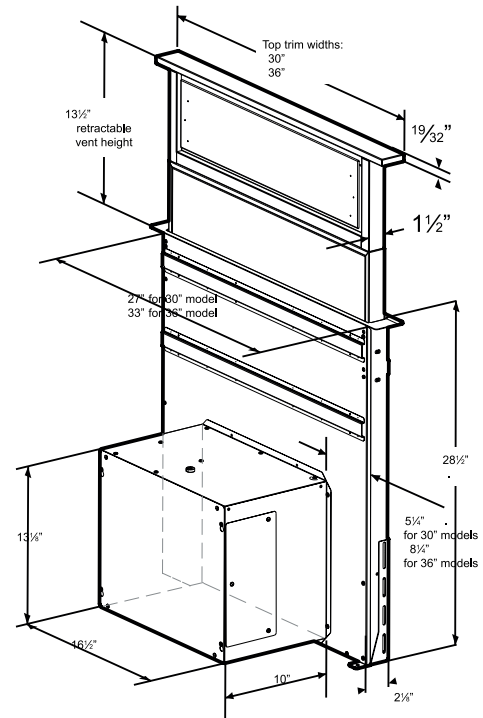

SPECIFICATIONS

Electrical 120V - 60 Hz | 410 Watt at 3.4 Amp

Controls Electronic Rotating Disc

Filter Perimeter Aspiration (Aluminium Mesh Filter Behind) Plus Perimeter Aspiration Plate

CFM 600 CFM

Noise (sones) at working speed Min 1.9 Max 8

KITS AND ACCESORIES

Replacement Grease Filter GRI0107245A

MODELS

RISE 30" Unit ERS630SS
RISE 36" Unit ERS636SS

COMFORT

TT

COMFORT







ALLASIO

COMFORT

30" 36"

Ducted or Recirculating with Recirculating Kit (sold separately)

The slim Allasio with 4 3/4" height is ideal where under-cabinet space is limited, plus the contemporary styling and gleaming colors will compliment other appliances and most cabinetry. Allasio features a 3-speed, 300 CFM internal blower, which provides sufficient ventilating power for most kitchens. The attractive, backlit push button controls illuminate an elegant blue glow when activated and allows the user to manage blower speeds and dual LED lamps.

Dishwasher-safe anodized aluminum mesh filters are easy to clean and a snap to remove and replace. Available in 30" or 36" widths, Allasio is designed for standard ducted installation, and can be installed as a recirculating system, using the Recirculating Kit.

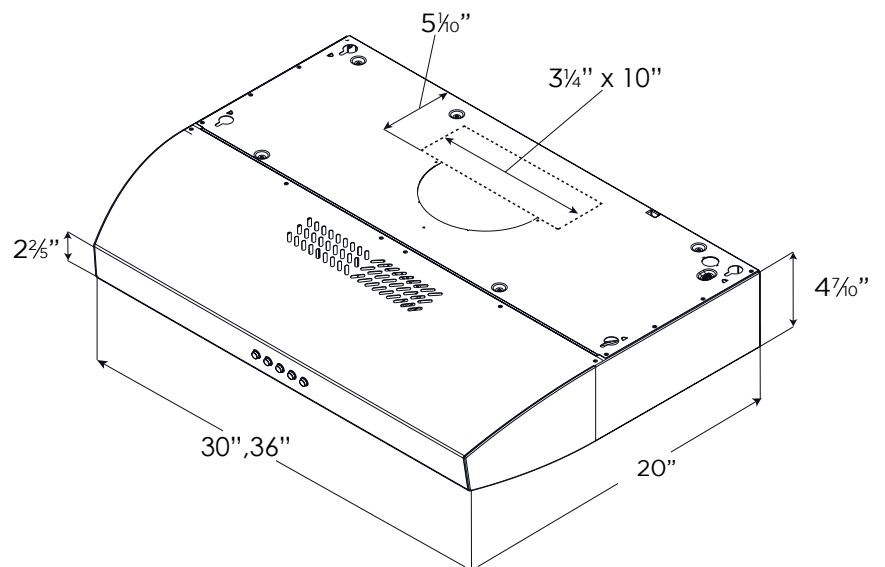

SPECIFICATIONS

Illumination	2 LED Premium Dimmable Lights, 2.5 w
Electrical	120V - 60 Hz 289 Watt at 2.43 Amp
Controls	Backlit Electronic Push Buttons
Filter	Dishwasher-Safe, Anodized Aluminum Mesh Filter
CFM	300 CFM
Noise (sones) at working speed	Min 1.93 Max 4.2

KITS AND ACCESSORIES

Recirculating Kit with 2 carbon filters:	KIT02178 / KIT02179
Non return valve/back draft damper 7" round:	KIT02723

MODELS

ALLASIO 30" Unit	EAL330S1
ALLASIO 36" Unit	EAL336S1
ALLASIO 30" WHITE	EAL330W1
ALLASIO 30" BLACK	EAL330B1



NEMI

COMFORT

30", 36"

Ducted or Recirculating with Recirculating Kit (sold separately)

Nemi sports a slender 5" height and soft curves, designed to modernize and perfectly fit kitchens where space is premium. Nemi features a 3-speed, 280 CFM internal blower, which provides sufficient ventilating power for most kitchens. The backlit push button controls allow for easy adjustment of blower speeds and dual LED lamps. A single dishwasher-safe anodized aluminum mesh filter is easy to clean. Available in 30" or 36" widths, Nemi is designed for standard ducted installation, and can be installed as a recirculating system, using the Recirculating Kit, available as an accessory. For design versatility, Nemi is available in a choice of stainless steel, black, white or biscuit finishes.

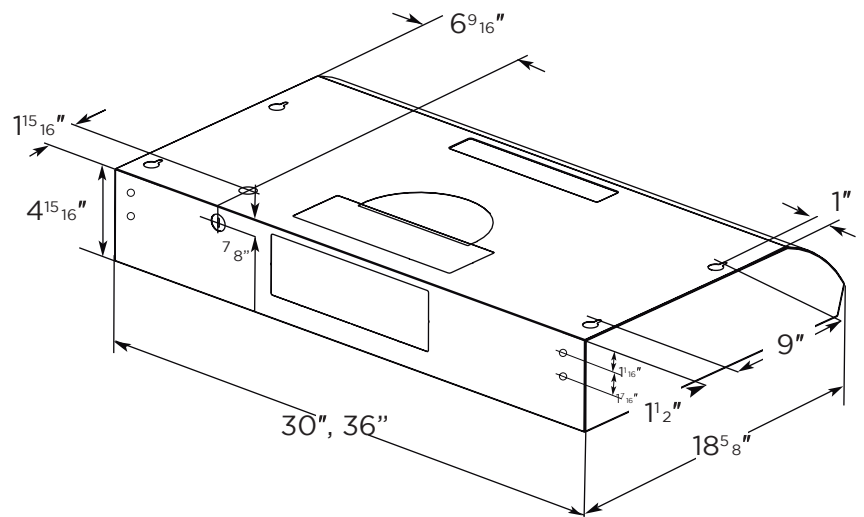

SPECIFICATIONS

Illumination	2 LED Lights
Electrical	120V - 60 Hz 115 Watt at 1 Amp
Controls	Hidden electronic touch controls
Filter	Dishwasher- Safe, Aluminum Mesh
CFM	280 CFM
Noise (sones) at working speed	Min 1.5 Max 4.7

KITS AND ACCESSORIES

No Return Valve 7"	KIT02723
Duct Transition 7"	KIT02722

MODELS

NEMI 30" Unit	ENM230S1
NEMI 36" Unit	ENM236S1
NEMI 30" White	ENM230W1
NEMI 30" Black	ENM230B1



TOBLINO

COMFORT

24", 30" 36"

Ducted or Recirculating with Recirculating Kit (sold separately)

Toblino, with its super sleek hood design that's only 2" high is the perfect complement for modern kitchen designs that feature futuristic sharp architectural lines. Available in 24", 30" or 36" widths, Toblino features backlit push button controls, LED lights and 3 speed blower.

Toblino features a telescopic chimney for up to 8'5" ceilings. Designed for standard ducted installation, Toblino can also be installed as recirculating system using the kit available as an accessory.

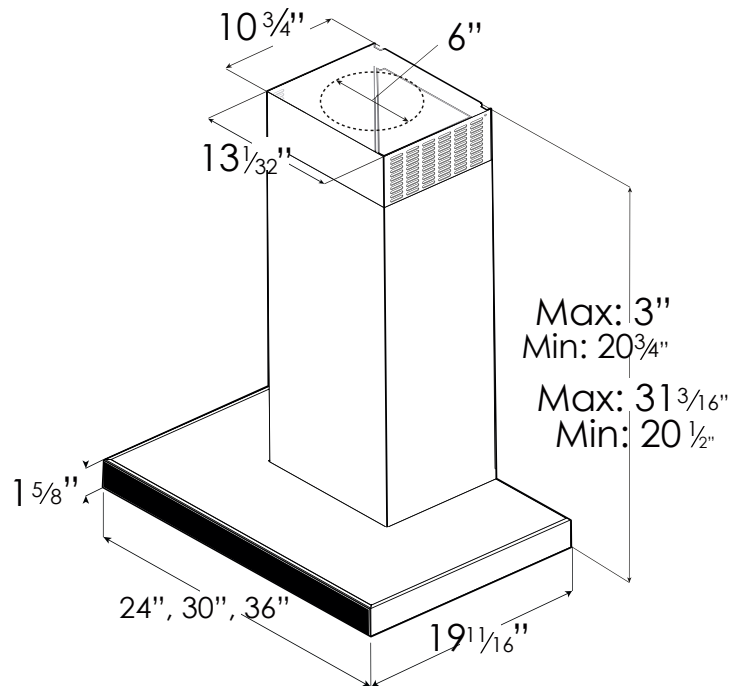

SPECIFICATIONS

Illumination	2 LED
Electrical	120V - 60 Hz 300 Watt at 2.5 Amp
Controls	Backlit Electronic Push Button
Filter	Dishwasher-Safe, Aluminum Mesh Filter
CFM	400 CFM
Noise (sones) at working speed	Min 0.78 Max 6

KITS AND ACCESSORIES

Long Chimney Extension Kit:	KIT02785
Recirculating Kit:	KIT0102875
CFM Reduction Kit	KIT02748

MODELS

TOBLINO 24" Unit	ETB424SS
TOBLINO 30" Unit	ETB430S2
TOBLINO 36" Unit	ETB436S2



POTENZA

COMFORT

30", 36"

Ducted or Recirculating with Recirculating Kit (sold separately)

Potenza combines curved glass and stainless steel to create a light and airy environment, which is perfect for any contemporary kitchen.

The flowing designs of 30" or 36" widths come with powerful 400 CFM blower that can support the cooking demands of most kitchens. Backlit push button controls manage multiple functions, including LED lighting and 3 speed blower. Potenza also features a telescopic chimney for up to 8' 5" ceilings.

Designed for standard ducted installation, Potenza can also be installed as a recirculating system using the kit available as an accessory.



SPECIFICATIONS

Illumination	2 LED
Electrical	120V - 60 Hz 300 Watt at 2.5 Amp
Controls	Backlit Push Button
Filter	Dishwasher-Safe, Aluminum Mesh Grease Filters
CFM	400 CFM
Noise (sones) at working speed	Min 0.91 Max 5.9

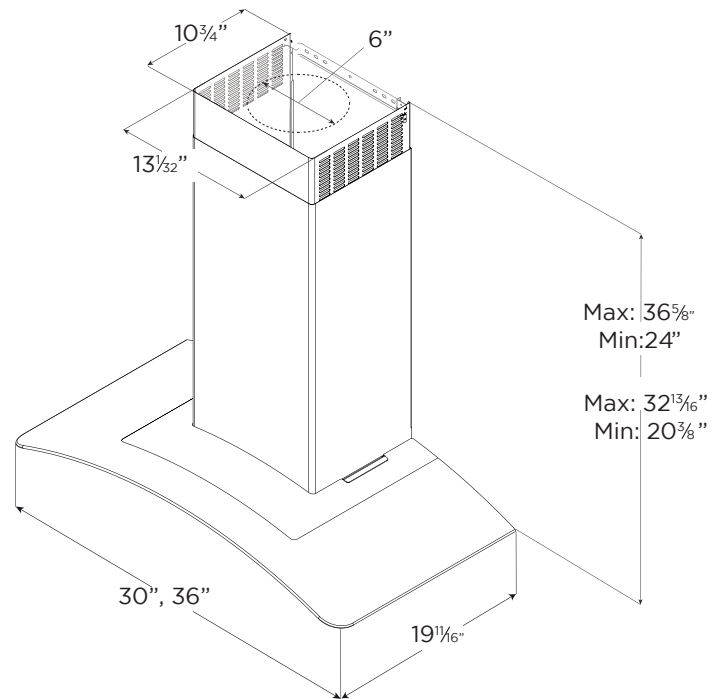

KITS AND ACCESSORIES

Optional Recirculating Kit	KIT0102875
Optional Long Chimney Extension	KIT0100315
Optional CFM Reduce Kit	KIT02748

MODELS

POTENZA 30" Unit	EPT430S2
POTENZA 36" Unit	EPT436S2

ASTI

COMFORT







ASTI

COMFORT

22", 28"

Ducted or Recirculating with Recirculating Kit (sold separately)

Asti is designed for discreet mounting inside cabinetry, fits perfectly into 12" deep cabinetry and is ideal for kitchens where space is limited or the range hood needs to be out of sight.

Asti comes equipped with a powerful 400 CFM blower that can handle most cooking needs.

Convenient Backlit Electronic Push Button Controls operate the 3 speed blower and LED lighting, while dishwasher safe anodized aluminum mesh filters offer easy maintenance. Asti is designed for standard ducted or recirculating installation.

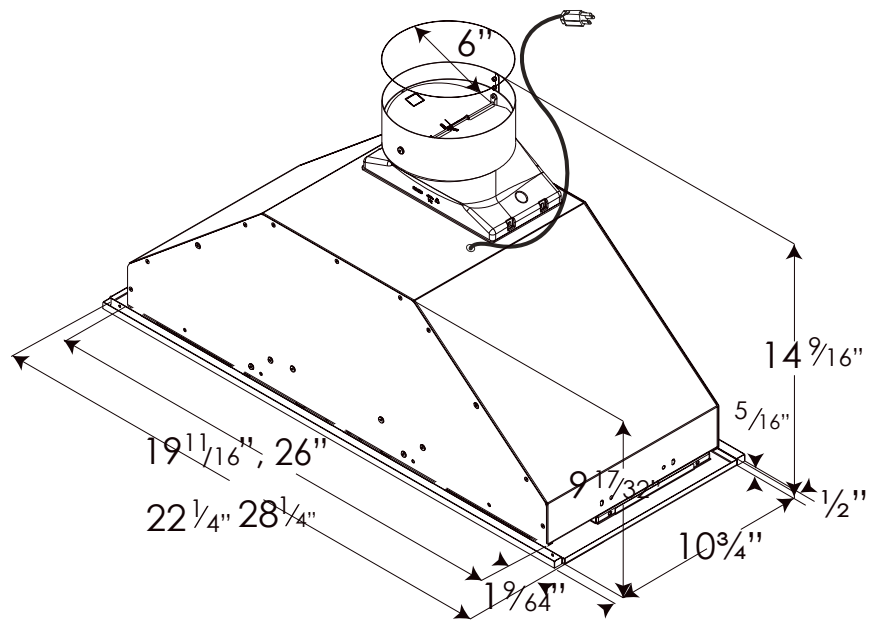

SPECIFICATIONS

Illumination	2 LED, 2.1 Watts
Electrical	120V - 60 Hz 340 Wattage
Controls	Backlit electronic Push Button 3-Speed
Filter	Dishwasher-Safe, Anodized Aluminum Mesh Filter
CFM	400 CFM
Noise (sones) at working speed	Min 1.5 Max 5.9

KITS AND ACCESSORIES

Recirculating Kit with 2 carbon filters:	KIT02770 / KIT02770
22" Hood Liner	KIT02773
28" Hood Liner	KIT02774

MODELS

ASTI 22" Unit	EAS422SS
ASTI 28" Unit	EAS428S1



ASTI 30"

COMFORT

30"
Ducted or Recirculating with Recirculating Kit
(sold separately)

Asti is designed for discreet mounting inside cabinetry, fits perfectly into 12" deep cabinetry and is ideal for kitchens where space is limited or the range hood needs to be out of sight.

Asti comes equipped with a powerful 400 CFM blower that can handle most cooking needs.

Convenient Backlit Electronic Push Button Controls operate the 3 speed blower and LED lighting, while dishwasher safe anodized aluminum mesh filters offer easy maintenance. Asti is designed for standard ducted or recirculating installation.

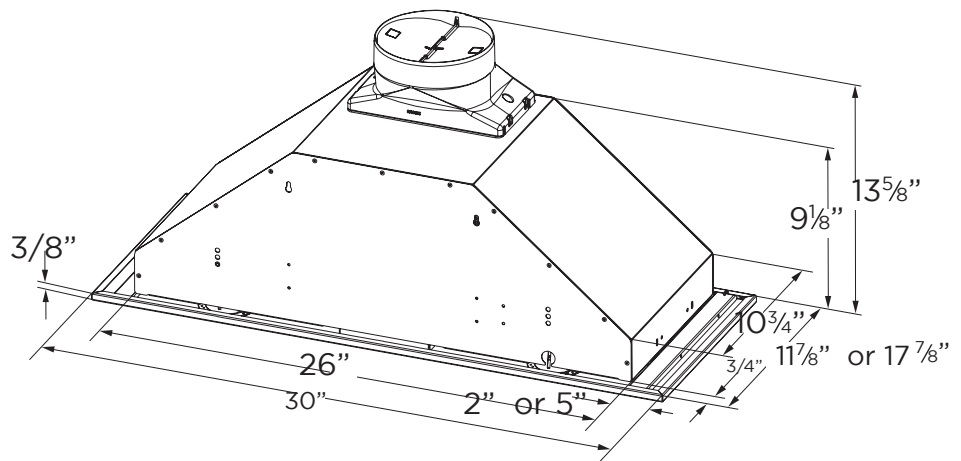

SPECIFICATIONS

Illumination	2 LED, 2.1 Watts
Electrical	120V - 60 Hz 340 Wattage
Controls	Mechanical Push Button
Filter	Aluminum mesh + Stainless Steel layer
CFM	400 CFM
Noise (sones) at working speed	Min 1.5 Max 5.9

KITS AND ACCESORIES

Recirculating Kit with 2 carbon filters:	KIT02770
CFM Reduction Kit:	KIT02748

MODELS

ASTI 30" Unit	EAS430SS
---------------	----------



SORA

COMFORT

30", 36"

Ducted or Recirculating with Recirculating Kit (sold separately)

Available in 30" and 36" widths and only 10" high, the Sora offers professional styling and adequate power for most cooking needs. Sora features a 400 CFM blower with dishwasher safe anodized aluminum mesh filters, halogen lighting and rocker switch controls for convenience and safety. Sora is sure to deliver easy maintenance, higher efficiency and a cleaner kitchen.

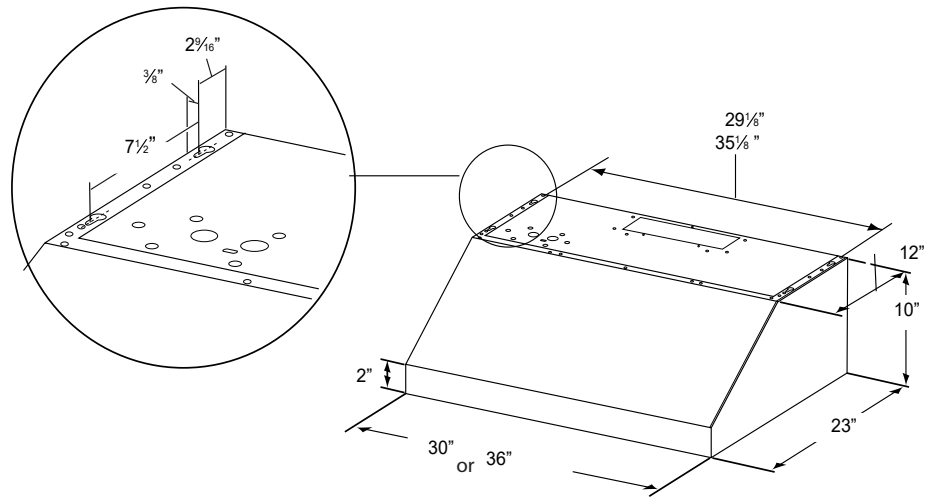

SPECIFICATIONS

Illumination	2, 2.1 W LED Lamps
Electrical	120V - 60 Hz 340 Wattage at 2.8 Amps
Controls	Rocker Controls
Filter	2, Baffle Slot Grease Filters
CFM	400 CFM
Noise (sones) at working speed	Min 1.5 Max 5.9

KITS AND ACCESSORIES

Recirculating Kit	KIT02770
CFM Reduction Kit	KIT02748

MODELS

SORA 30" Unit	ESR430SS
SORA 36" Unit	ESR436SS



TT

COMFORT

24", 30" 36"

Ducted or Recirculating with Recirculating Kit (sold separately)

The ultra slim design of TT hides quietly within cabinetry and extends less than 2" below the edge. When called to action, the horizontal visor effortlessly pulls out to provide added air capture during cooking. TT design is ideal for smaller kitchens or where under-cabinet space is limited. The 400 CFM blower provides more than adequate power for everyday cooking. The 3 speed blower and LED lighting are operated with modern electronic push button controls, which are out of sight and behind the visor when idle.

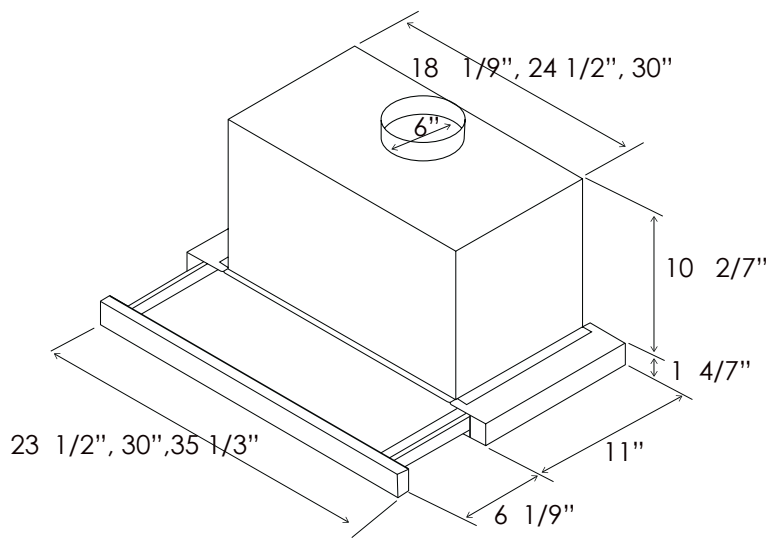

SPECIFICATIONS

Illumination	2 LED , 2.1 W
Electrical	120V - 60 Hz
Controls	Hidden electronic push controls
Filter	1 Anodized Dishwasher Safe Aluminum Mesh Filters
CFM	400 CFM
Noise (sones) at working speed	Min 1.5 Max 5.9

KITS AND ACCESSORIES

CFM Reduction Kit:	KIT02748
Recirculating Kit:	CFC0038668
6" round plastic deflector	DF01EA

MODELS

TT 24" Unit	ETT424S1
TT 30" Unit	ETT430SS
TT 36" Unit	ETT430SS



VOLTERRA

COMFORT

24", 30", 36"

Ducted or Recirculating with Recirculating Kit
(sold separately)

Volterra, with its pyramid shaped angles and stainless steel finish, makes a striking visual statement to any kitchen. Available in 24", 30" or 36" widths, Volterra features backlit push button controls, LED lighting and 3-speed blower. It also features a telescopic chimney for up to 9'2" ceilings.

Designed for standard ducted installation Volterra can also be installed as a recirculating system using the kit available as an accessory.

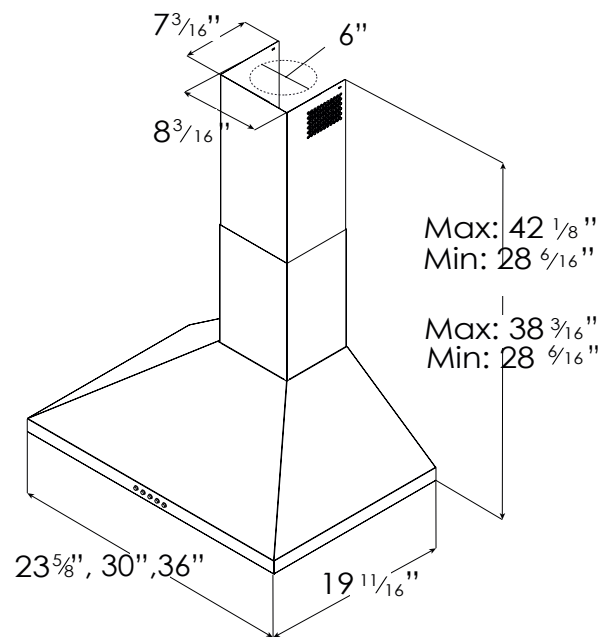

SPECIFICATIONS

Illumination	2 LED Lights
Electrical	120V - 60 Hz 265 Watt at 2.2 Amp
Controls	Backlit Push Button
Filter	Dishwasher-Safe, Aluminum Mesh Filter
CFM	400 CFM
Noise (sones) at working speed	Min 0.83 Max 6

KITS AND ACCESORIES

Long Chimney Extension Kit:	KIT02762
Recirculating Kit:	KIT02766
CFM Reduction Kit:	KIT02748

MODELS

VOLTERRA 24" Unit	EVL424SS
VOLTERRA 30" Unit	EVL430S2
VOLTERRA 36" Unit	EVL436S2



GUBBIO

COMFORT

24"
Ducted or Recirculating with Recirculating Kit
(sold separately)

GUBBIO is the perfect option for a functional kitchen with reduced spaces. With a powerful aspiration of 250 CFM, three speeds and LED lights, this undercabinet Hood is ideal for builder projects.

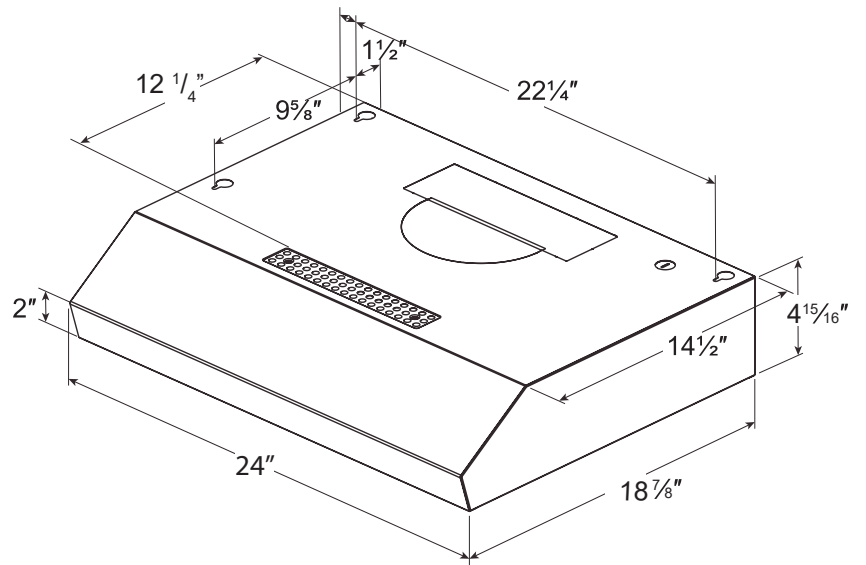

SPECIFICATIONS

Illumination	2 LED, 2.1 Watts
Electrical	120V - 60 Hz
Controls	Slider control
Filter	2 Aluminum mesh
CFM	280 CFM
Noise (sones) at working speed	Min 1.5 Max 5.9

KITS AND ACCESSORIES

Recirculating Kit	KIT0140997
No return valve 7"	KIT02723
Duct Transition 7"	KIT02722

MODELS

GUBBIO 24" Unit	EGB224SS
-----------------	----------

CONTACT INFO

TECHNICAL SUPPORT & WARRANTY SERVICE

USA & CANADA - WESTERN PROVINCES

888 732 8018

elica@servicepower.com

CANADA - ONTARIO PROVINCE

888 651 2534

service@agintl.qc.ca

CANADA - QUEBEC & ATLANTIC PROVINCES

888 463 0119

service@ateliersgpaquette.com

PARTS, KITS AND ACCESSORIES

FOR USA AND CANADA

Contact: Encompass

800 432 8542

encompass.com/brands/eli/Elica

or

Repair Clinic

800 269 2609

Repairclinic.com



*The product images shown are for illustration purposes only and may not be an exact representation of the product.

