



## CERVINIA UNDER-CABINET

ELICA PRO SERIES



LED light



IN/OUT Backlit Knob

Available in 30" and 36" widths and only 10" high, the Cervinia is a streamlined version of the full-size Calabria model. This hood features professional styling, seamless welded corner craftsmanship, a powerful 600 CFM blower with high airflow, heavy duty stainless steel baffle grease filters, Replaceable LED lighting, plus backlit hidden metallic in/out knobs for convenience and safety. Cervinia also delivers higher efficiency and easy maintenance for a cleaner kitchen.

### Dimensions | Models

30" W x 23" D x 10" H | ECV630S3  
CERVINIA 30"

36" W x 23" D x 10" H | ECV636S3  
CERVINIA 36"



HUSH



LED LIGHT



PROFESSIONAL PERFORMANCE



HEAT GUARD

FE ATURES

Size (in) & Type	30" or 36" wide Under-cabinet Chimney
Finish	Stainless Steel
Controls	IN/OUT Backlit Knob
Illumination	2 LED 7.5 watts LED light, replaceable lamps (1 intensity)
Installation Type	Ducted Installation Only
Blower Type	Speed 1, 170 CFMs Speed 2, 280 CFMs Speed 3, 440 CFMs Speed 4, 600 CFMs
Filter Type	2, Dishwasher-Safe, Professional Stainless Steel, Angled Baffle Filters
Noise (sones):	Min: 2.34, Max: 7 Sones
Duct Transition	Rectangular 3" x 1/4" x 10" (Top and rear)
Electrical	120 Volts, 60 Hertz

Line Drawing

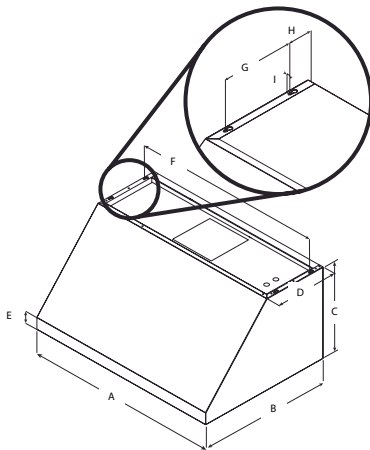

	Models	
	ECV 630S3	ECV636S3
A	30" ( 76 cm)	36" (91 .1 cm)
B	25" ( 63.5 cm)	
C	18" (45 .7 cm)	
D	12" (3 0.3 cm)	
E	1 1/2" (5 .7 cm)	
F	29 1/8" ( 74 cm)	35 1/8" ( 89.2 cm)
G	7 1/2" (19 cm)	
H	2 9/16" (6.5 cm)	
I	3/8" (1 cm)	

PLUS



**HUSH SYSTEM**  
An exclusive sound deadening technology that effectively reduces sound levels by over 35%, compared to typical range hoods.



**LED LIGHT**  
LED lighting is undoubtedly the smartest solution in terms of energy saving. Expected life time of over 20.000 hours, represents the most remarkable advantage of LED light bulbs.



**PROFESSIONAL PERFORMANCE**  
Special features and very high performances for models with aspiration capacity between 600 and 1200 CFM's, and noise level between 65 and 75 db(A) at maximum speed. The ideal complement of PRO ranges.



**HEAT GUARD**  
A safety feature that protects the hood and cabinetry from excessive heat, by sensing extreme temperatures (>158 degrees) and will automatically adjust the blower speed to HIGH. Blower speed will automatically adjust back once temperatures drop to a safe level.



**LED CONSUMER REPLACEABLE BULB**  
High quality LED lighting usually requires a skilled technician to replace lamps. Avoid this expense with Elica's new LED lamps that enable typical homeowners to replace in seconds.



**GREASE COLLECTOR**  
Professional grade, heavy gauge stainless steel baffle filters are the perfect choice for those with top chef dreams. Designed for high airflow cooking, the "S" shape design traps volumes of grease (for a cleaner kitchen), which is collected in trays for easy removal and cleaning.

Accessories

**6" Chimney Kit**  
CODE: KITO2159 / (30")  
CODE: KITO2158 / (36")

**12" Chimney Kit**  
CODE: KITO2160 / (30")  
CODE: KITO2161 / (36")

**Backsplash Kit**  
CODE: KITO2162 / (30")  
CODE: KITO2163 / (36")