

STAR HANGING



Exclusive materials



Ambient light



≥ 20"



≥ 28"



COLLECTION



"...I saw a small and shifting sphere, its radiance almost sublime. At first I thought it was rolling; but then I realized that this movement was an illusion produced by the dizzying sights that it enclosed" Borges: The Aleph. Fragments of dreams - or reality? - that are found in the everyday world, remind us that order and the evident do not always mean certainty, because objects can assume an infinity of new identities. Even, simultaneously, contain them.

evolution



Halogen Lamps & Incandescent Ambient Lamps

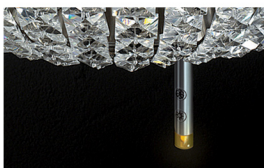

Magic Wand Controls



Aluminium Mesh Grease Filter & Long Life Carbon Filter

MODELS

EST319GL Star 19" Glass

DIMENSIONS

(18 5/16" W x 18 5/16" D x 13 1/2" H)

FEATURES

Size (in) & Type Finish	19" Wide, Island Mounted Hood Stainless Steel & Glass
Controls	Magic Wand
Illumination	1, 20W Halogen Flood lamp, 1 Intensity (Bulbs Included) 3, 40W Incandescent Ambient lamps, 2 Intensities
Installation Type	Recirculating Installation
Blower Type	300 CFM, 4-Speed Internal
Blower Performance	Speed 1, 100 CFM, 0.3 Sones Speed 2, 175 CFM, 2.1 Sones Speed 3, 250 CFM, 3.8 Sones Booster, 300 CFM, 4.1 Sones
Filter Type	1, Dishwasher-Grease Aluminium Filter 1, Long Life Carbon Filter (Included)
Standard Ceiling Height	Range 6' 10" - 10' 1"
Electrical	120V - 60 Hz 320 Watt at 2.7 Amps

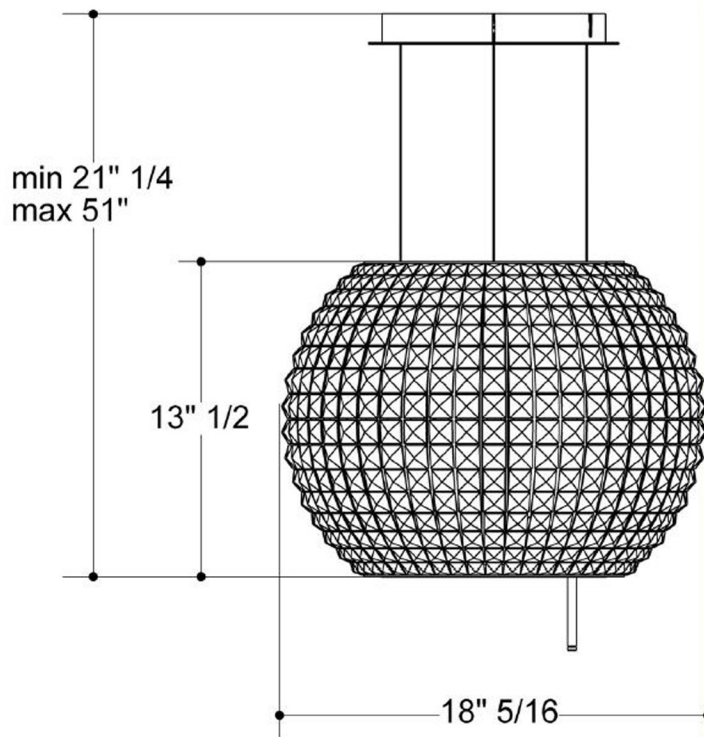

ACCESSORIES



Optional
Jet Remote
Control

CODE: KIT02183/1
MODEL: EXXRCDBL



Optional
Ceiling Heights
Range 6' 10" - 23' 3"

CODE: KIT01921
MODEL: EXXEKSS



Optional
Long Life Carbon
Filter

CODE: RG006A
MODEL: EXXRCKEC