

TECHNE PLUS SERIES

METEORITE

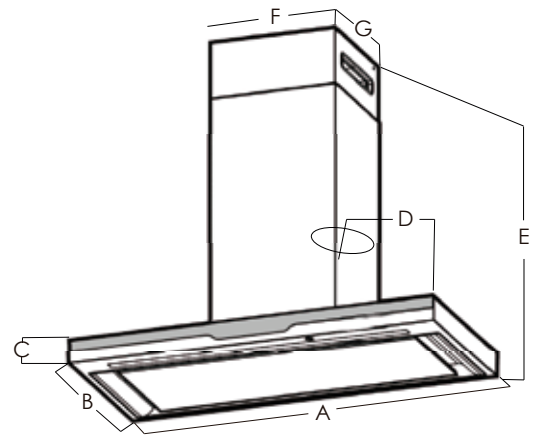

Black glass and polished stainless steel. Like all of the hoods in the Elica Stream line, also Meteorite is meant for anyone who loves high-technological solutions, where Elica hoods and cooktops, automatically communicate with one another, recognizing quality and quantity of cooking vapors, thus accordingly adjusting performance levels. With Perimeter Aspiration technology helps achieve Top Performance by delivering more powerful and efficient fume extraction plus it reduces noise. Meteorite includes a powerful 550 CFM blower, Strip LED lighting and a tunable white with glass capacitive touch controls



	EMT636SS
A	Min: 35 ²³ / ₆₄ " (89.8 cm) Max: 47 ¹¹ / ₆₄ " (119.8 cm)
B	17 ¹ / ₈ " (43.5 cm)
C	2 ²³ / ₆₄ " (6 cm)
D	13 ³ / ₁₆ " (33.5 cm)
E	Min: 27 ²³ / ₃₂ " (70.4 cm) Max: 50 ²⁵ / ₃₂ " (129 cm)
F	12 ¹ / ₆₄ " (30.8 cm)
G	11 ²⁷ / ₆₄ " (33.5 cm)

TECHNE PLUS SERIES

METEORITE





SPECIFICATIONS

	36" Unit
Model:	EMT636SS
Dimensions:	36" W x 17 1/8" D x 28" H
Blower Type(internal):	550 CFM(4-speed)
Blower Performance:	
Speed 1	192 CFM
Speed 2	310 CFM
Speed 3	450 CFM
Speed 4	550 CFM
Noise (sones):	Min:1.7, Max:7
Woking Speed	
Finish:	Stainless Steel with black glass
Controls:	Touch Control 3 Speeds + Booster (sensor)
Illumination:	Strip LED 7 Watts 2700 - 6000K
(replaceable lamps 1 intensity)	
Filter Type:	Aluminim Mesh Filter + Perimeter Aspiration
Duct Transition:	Top Round 6"
Installation Type:	Ducted
Electrical:	120V - 60 Hz 460 Watt at 3.8 Amp
KITS:	
Recirculating Kit	KIT0102875
Long Chimney Extension:	KIT02785
CONSUMABLE PARTS:	
Charcoal Filter Replacement:	KIT0141918
Grease Filter Replacement:	GF04YB

Consumable parts are sold in units of one (1). Order accordingly

PLUS FEATURES

 **WIRELESS CONNECTIVITY** - Wireless technology allows the transmission of real time information about cooking (active zones, pots, temperature), to your hood. Elica hoods with STREAM technology will process data and function totally automatically.

 **TOUCH CONTROL** - Enjoy effortless cooking, and fully control each cooking zone with the tip of a single finger.

 **PERIMETER ASPIRATION** - This technology draws air through a narrowed channel around a face plate, which increases suction, without increasing blower speed or energy consumption.

 **LONG LIFE FILTER** - One of a kind odour filter, capable of regenerating itself and of lasting up to 3 years. To maintain these characteristics, the filter only requires simple maintenance: wash every 2 or 3 months with hot water and mild soap (also in dishwasher at 65 degrees) and dry in the oven for ten minutes at 100 degrees

 **TOP PERFORMANCE** - Excellent performance for models equipped with this plus. High fume capturing capacity with an average aspiration range of 600 CFM's and a noise level be tween 60-65 db(A)at maximum speed (reference point varies based on the hood category).

 **AMBIENT LIGHT** - Transforms a kitchen appliance into a true lighting element.