

LUMINA NRS

Version

FNLUM36I5SS / Island – 36" (90 cm) Steel – 500 CFM

Collection

Silence - NRS

EAN code

8034122347226

FEATURES

- Scotch brite stainless steel (AISI 304)**
- Tempered glass with steel look finish**
- NRS technology for a quieter kitchen**
- Touch control + 24 h function**
- Fluorescent ambient light**
- Metallic grease filter, removable and washable**
- Optional charcoal filter**

OPTIONAL ACCESSORIES

KACL.572#1

Extension H1200 - Island

KACL.815

Protective cleaning cloths for stainless steel (box 10 pcs)

KACL.400

Silent / Conveyor NRS

101078900

High performance filter

TECHNICAL FEATURES

Installation type

Island

Dimensions

36 " / 90 "

Finish

Scotch brite stainless steel (AISI 304)

Tempered glass with white finish

Motor

500 CFM

Type of control

Touch control

Speed settings

4

Filter

Metallic filter "Base" - 274x274 mm - 2 pz

Minimum distance

Gas hob: 26 in

Electric hob: 21 in

PACKAGING:WEIGHTS AND VOLUMES

Gross weight

115 lbs

Net weight

100 lbs

Volume

22 ft³

Packaging size

Length

43 in

Height

35 in

Depth

26 in

CONSUMPTION AND CONNECTION FEATURES

Maximum consumption

340 W

Voltage / Frequency

120V 60Hz

Plug type

Standard

MOTOR TECHNICAL SHEET

Maximum capacity

610 m³/h

I.E.C. 61591

Maximum noise level

54,5 dB(A)re1pW

I.E.C.60704-2-13

Maximum pressure (Pa)

510 Pa

Max. motor power

224 W

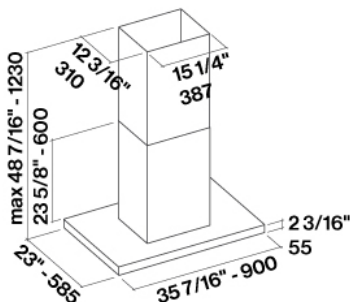

LUMINA NRS

Version

FNLUM36I5SS / Island – 36" (90 cm) Steel – 500 CFM

Collection

Silence - NRS

EAN code

8034122347226

MOTOR TECHNICAL SHEET

Motor Speed	1	2	3	4
Noise level dB(A)re1pW-I.E.C.60704-2-13	37	41	46	54,5
Capacity (m3/h) I.E.C.61591 Normalized Pipes	220	290	375	610
Maximum pressure (Pa)	390	440	490	510
Motor Power (W)	130	150	178	224
Air outlet	150	150	150	150