

MIRA

Version

FDMIR16I5SS-R Island 16" (40 cm) - 500 CFM

Collection

Design

EAN code

8034122205953



Photograph is for information purposes only
May not correspond to the selected version

FEATURES

Perimeter suction
Electronic control
LED lighting
Metallic grease filter, removable and washable
Optional charcoal filter
SRS Speed reduction system

Recommended mounting height from cooking surface to hood bottom: 24" - 35"

OPTIONAL ACCESSORIES

FDNUMTR600

FDNUMTR600 - Motor 600 CFM for North America

FFCHAR3C0BL

FFCHAR3C0BL - Round charcoal filter Ø 6" - Type 6

KACL.815

Protective cleaning cloths for stainless steel (box 10 pcs)

101080244

Metallic filter "Base" - 277x294 mm

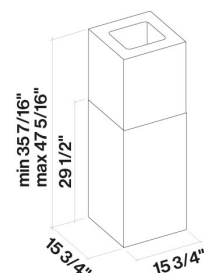

TECHNICAL FEATURES

Installation type

Island

Dimensions

16 / 40 cm

Finish

Scotch brite stainless steel (AISI 304)

Motor

500 CFM

Type of control

Electronic control

Speed settings

4

Lighting

Led 4x1,2 W - 3200 K

Filter

Metallic filter "Base" - 277x294 mm

Charcoal filter

FFCHAR3C0BL - Round charcoal filter Ø 6" - Type 6 (optional)

Minimum distance

Gas hob: 24 in

Electric hob: 21 in

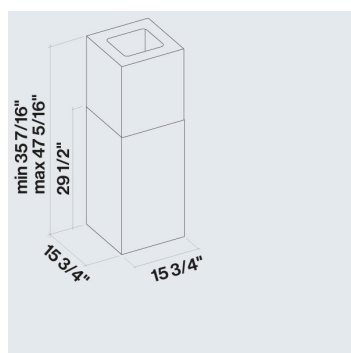

PACKAGING:WEIGHTS AND VOLUMES

Gross weight

80 lbs

Net weight

71 lbs

Volumes

10 ft³

Packaging size

Length

40 in

Height

19 in

Depth

24 in

CONSUMPTION AND CONNECTION FEATURES

Maximum consumption

280 W

Plug type

Hood comes standard with Nema 5-15P power cord