

MOVE

Version

FDMOV36W5SW / Built-in - 36"
(90 cm) White - 500 CFM

Collection

Design

EAN code

8034122356310



Photograph is for information purposes only
May not correspond to the selected version

FEATURES

- Scotch brite stainless steel (AISI 304)**
- White tempered glass**
- Electronic control**
- LED lighting**
- Metallic grease filter, removable and washable**
- Optional combined regenerable Carbon.Zeo filter**
- Possible to duct wall mounted from rear**
- Optional Chimney**
- Optional glass shelf**
- Opening frontal**

OPTIONAL ACCESSORIES

KACL.815

Protective cleaning cloths for stainless steel (box 10 pcs)

KACL.798#21F

Motor 600 CFM

TECHNICAL FEATURES

- Installation type**
Built-in
- Dimensions**
36 " / 90 "
- Finish**
Scotch brite stainless steel (AISI 304)
- Lower part in white tempered glass**
- Motor**
500 CFM
- Type of control**
Electronic control
- Speed settings**
4
- Lighting**
Led 3x1,2 W - 3200 K
- Filter**
Metallic filter "Base" - 198x161 mm - 2 pz
- Charcoal filter**
Carbon.Zeo filters
- Minimum distance**
Gas hob: 21 in
Electric hob: 21 in

PACKAGING:WEIGHTS AND VOLUMES

- Gross weight**
45 lbs
- Net weight**
38 lbs
- Volume**
7 ft³
- Packaging size**
Length
40 in
Height
19 in
Depth
16 in

CONSUMPTION AND CONNECTION FEATURES

- Maximum consumption**
280 W
- Voltage / Frequency**
120V 60Hz

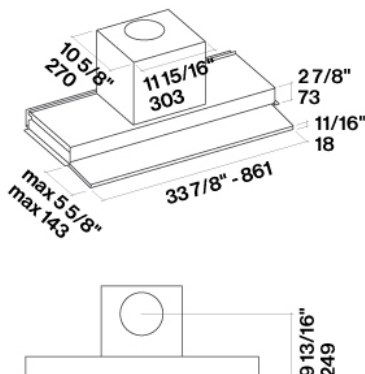

Optional chimney

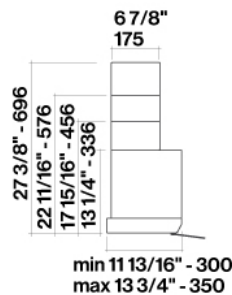

Optional shelf

