

# DISHWASHER

## *use & care*

Introduction.....	2	Operating Instructions.....	8
Important Safety information.....	3	Care and Cleaning .....	11
Features.....	5	Troubleshooting.....	19
Controls and settings .....	6	Limited Warranty .....	22

# 2

## INTRODUCTION

### Welcome to our family

Thank you for bringing Frigidaire into your home! We see your purchase as the beginning of a long relationship together.

This manual is your resource for the use and care of your product. Please read it before using your appliance. Keep it handy for quick reference. If something doesn't seem right, the troubleshooting section will help you with common issues.

FAQs, helpful tips and videos, cleaning products, and kitchen and home accessories are available at [www.frigidaire.com](http://www.frigidaire.com).

We are here for you! Visit our website, chat with an agent, or call us if you need help. We may be able to help you avoid a service visit. If you do need service, we can get that started for you.

Let's make it official! Be sure to register your product.

Keep your product info here so it's easy to find.

Model Number \_\_\_\_\_

Serial Number \_\_\_\_\_

Purchase Date \_\_\_\_\_



#### NOTE

The dishwasher is programmed to remember your last cycle so you do not have to reset each time. To start the dishwasher using the same cycle and options selected on the previous wash, just press the START pad.



#### NOTE

Not all cycles and options available on all models.



#### NOTE

The filters will need to be cleaned to maximize wash performance during the life of your dishwasher. See "Recommended Frequency to Clean Your Filters" for a cleaning schedule.



#### NOTE

**Very Important Information - Read Before Operating Your Dishwasher!**

**Normal Operating Sounds**

This dishwasher does not sound like most dishwashers - IT'S QUIETER.

Your Direct Feed Wash System dishwasher uses energy efficient motors for the wash and drain portions of the cycle you select. Each cycle has a series of water fills and drains for washing and rinsing dishes. As each cycle begins, you may-or may not- hear the drain motor. The next sound you will hear is the splashing water as it enters the tub.

**PLEASE BE ADVISED:** If you compare this dishwasher to previous models, you may be surprised at what you DON'T hear.



#### NOTE

**Why Energy Efficient Units run long cycles:** Several factors are important to washing dishware. The energy use of the dishwasher was reduced by applying more of the factors that don't use so much energy and less of the ones that use more. As a result, you will see that the wash cycles take longer.

## IMPORTANT SAFETY INFORMATION



### WARNING

Please read all instructions before using this dishwasher.

### For your Safety

- Use your dishwasher only as instructed in this User Manual.
- This Manual does not cover every possible condition and situation that may occur. Use common sense and caution when installing, operating and maintaining any appliance.
- NSF certified residential dishwashers are not intended for licensed food establishments.
- **DISHWASHER MUST BE ELECTRICALLY GROUNDED.** Read the Installation Instructions for details.
- This dishwasher is designed to operate on regular house current (120V, 60Hz). Use a circuit equipped with a 15 ampere fuse or circuit breaker. Use a 20 ampere fuse if dishwasher is connected with a food disposer.
- Do not operate dishwasher unless all enclosure panels are in their proper place.
- To avoid entrapment and/or suffocation, remove door or door latch mechanism from any dishwasher that is discarded or not in use.
- Keep young children and infants away from dishwasher when it is operating.
- Do not let children abuse, sit, stand or play on door or racks of a dishwasher.
- Use only detergents and rinse agents recommended for use in a dishwasher.
- Store dishwasher detergent and rinse agents out of the reach of children.
- Do not wash plastic items unless marked: "Dishwasher Safe" or equivalent. Check with manufacturer for recommendations, if not marked. Items that are not marked dishwasher safe may melt and create a potential fire hazard.
- Disconnect electrical power to dishwasher before servicing.
- If the dishwasher drains into a food disposer, make sure disposer is completely empty before running dishwasher.
- Repairs should be done by a qualified technician.
- Do not tamper with controls.
- Do not touch the heating element during or immediately after
- Use care unloading the dishwasher when the Sanitize option has been selected. Contents may be hot to the touch immediately after the end of cycle.
- Water vapor in the tub may be hot when Sanitize or other high temperature programs has been selected. Use care and do not let small children play around or touch the hot vapor area when open the door during washing cycle.
- When loading items to be washed:
  - Locate sharp items and knives so that they are not likely to damage the door seal or tub.
  - Load sharp items and knives with the handles up to reduce the risk of cut-type injuries.
- Under certain conditions, hydrogen gas may be produced in a hot water, system that has not been used for 2 weeks or more. **HYDROGEN GAS IS EXPLOSIVE.** If hot water system has not been used for such a period, before using dishwasher, turn on for several minutes This will release any accumulated hydrogen gas. **HYDROGEN GAS IS FLAMMABLE.** Do no smoke or use an open flame during this time.
- Do not store or use combustible materials, gasoline or other flammable vapors and liquids in the vicinity of this or any other appliance.



### WARNING

To reduce the risk of fire, electrical shock or injury when using your dishwasher, follow the above basic precautions.



### WARNING

This symbol will help alert you to such dangers as personal injury, burns, fire and electrical shock.

# 4

## IMPORTANT SAFETY INFORMATION



### WARNING

To reduce the risk of fire, electrical shock or injury when using your dishwasher, follow the previous basic precautions .



### WARNING

Please read all instructions before using this appliance.

### Safety Definitions

 This is the safety alert symbol. It is used to alert of potential personal injury hazards. Obey all safety messages that follow this symbol to avoid possible injury or death.



### DANGER

DANGER indicates an imminently hazardous situation which, if not avoided, will result in death or serious injury.



### WARNING

WARNING indicates a potentially hazardous situation which, if not avoided, could result in death or serious injury.



### CAUTION

CAUTION indicates a potentially hazardous situation which, if not avoided, may result in minor or moderate injury.



### IMPORTANT

IMPORTANT indicates installation, operation or maintenance information which is important but not hazard-related.

### Child Safety

Destroy or recycle the carton, plastic bags, and any exterior wrapping material immediately after the dishwasher is unpacked. Children should **NEVER** use these items to play. Cartons covered with rugs, bedspreads, plastic sheets or stretch wrap may become airtight chambers, and can quickly cause suffocation.

### Safety Instructions

- DO NOT store or use gasoline, or other flammable liquids in the vicinity of this or any other appliance. Read product labels for warnings regarding flammability and other hazards.
- Remove all staples from the carton. Staples can cause severe cuts, and also destroy finishes if they come in contact with other appliances or furniture.

### SAVE THESE INSTRUCTIONS

Your dishwasher cleans by spraying a mixture of hot water and detergent through the spray arms against soiled surfaces. First, the dishwasher drains for a few seconds to remove soils dropped while loading, then fills with water covering the filter area. Water is then pumped through the spray arms. Soil particles go through and across the filter and down the drain as the water is pumped out. This series of steps are repeated as needed. The number of water fills varies with the cycle being used.

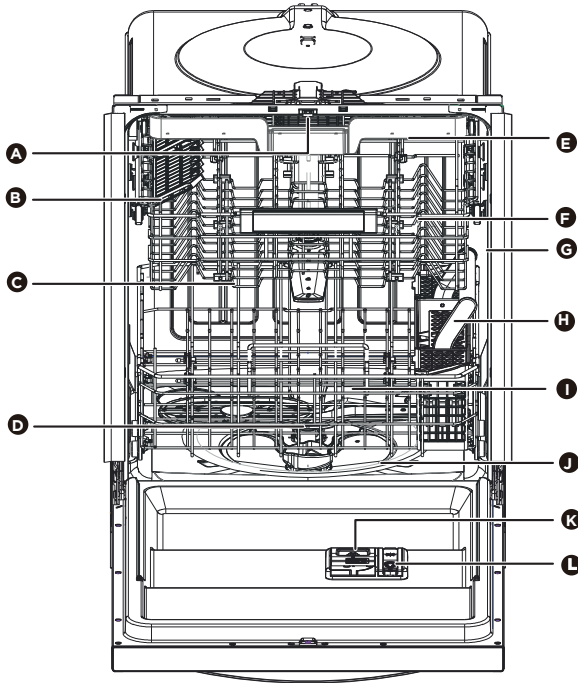

**Features may vary according to model**

<b>A</b>	Upper spray arm
<b>B</b>	Cup shelf
<b>C</b>	Middle Spray Arm
<b>D</b>	Lower spray arm
<b>E</b>	Top rack
<b>F</b>	upper rack
<b>G</b>	Tub gasket

<b>H</b>	Silverware basket
<b>I</b>	Bottom rack
<b>J</b>	Heating element
<b>K</b>	Detergent dispenser
<b>L</b>	Rinse aid dispenser



## IMPORTANT

Accessories are available for your appliance and may be purchased at [Frigidaire.com](http://Frigidaire.com) or by calling 1-800-374-4432 (Frigidaire.ca or 1-800-265-8352 in Canada) or from an authorized seller.

# 6

## CONTROLS AND SETTINGS

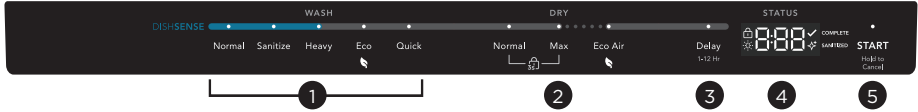

### NOTE

Your dishwasher uses a DishSense™ Technology to understand how much food is on the dishes and then adjusts the cycle accordingly.



### CAUTION

#### Property Damage Hazard

Before starting dishwasher be sure that the water is connected and turned on. Failure to do so may cause damage to the pump seal and result in water leakage.

Cycle times are approximate and will vary with options selected. Hot water is necessary to activate dishwasher detergent and melt fatty food soils. An automatic sensor will check the incoming water temperature and, if it is not hot enough, the cycle will be lengthened for automatic water heating in the main wash and final rinse of all cycles.



### NOTE

Lights on the console will remain on once the door is shut and wash cycle begins. If it is preferred to have the lights turn off while cycle is running see Console Lights section for instructions.

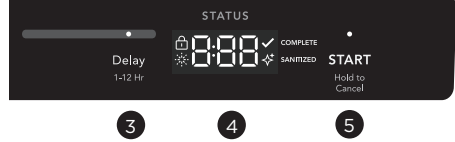

### Recommended Cycle for typical use:

The **Normal Wash** cycle with its factory default options of normal temperature and heated dry together provide the best all around performance. This cycle selection is recommended for everyday use and is suitable for a large range of both dish load sizes and food quantities remaining on those dishes.

### Wash Cycle Selections

- 1 Press button to select corresponding washing cycle and the cycle indicator will illuminate. **Normal, Sanitize, Heavy, ECO, Quick** can be selected.

#### Normal

Normal cycle is to completely wash and dry a full load of normally soiled dishes. The energy usage label is based on this cycle and option combination with the upper rack in the raised position. This cycle uses a DishSense.

#### Sanitize

The sanitize option sanitizes dishes and glassware in accordance with NSF International NSF/ANSI Standard 184 for Residential Dishwashers. Certified residential dishwashers are not intended for use in licensed food establishments. This cycle uses a DishSense

#### Heavy

Heavy cycle is for pots, pans, casseroles and dinnerware with dried-on or baked on soil. This cycle uses a DishSense

#### ECO

This cycle is selected for an energy saving performance. NormalDry and MaxDry are not optional with this cycle.

#### Quick

Quick cycle is for lightly soiled or well-rinsed dish loads.

## 2 Dry Options

The programmed cycles default to the MaxDry option, except Sanitize and Quick cycle.

### NormalDry

When **NormalDry** option is selected, the heater will work during the drying process.

**NormalDry** option can be used with all cycles. (Not recommended for daily use.)

### MaxDry

When the **MaxDry** option is selected, the heater operation time will be extended to further improve drying performance.

**MaxDry** option can be used with all cycles except **Sanitize and Quick**. (Not recommended for daily use.)

### Eco Air

When **Eco Air** option is selected, the door will open automatically at the end of cycle to achieve better drying performance. **Eco Air** option can be used with all cycles.

### Air Dry

When **NormalDry**, **MaxDry** and **Eco Air** are not selected, the heater will be de-activated during the drying phase of the selected wash cycle. **Air Dry** means drying with residual air heat.

### Child Lock Controls

Lock the dishwasher controls by pressing and holding the **NormalDry** button and **MaxDry** button simultaneously until the lock icon comes on to prevent children from starting the dishwasher or accidentally changing the wash cycle. To unlock the controls, press and hold the **NormalDry** button and **MaxDry** button until the lock icon goes off.

### Automatic Door Opener (ADO)

To get a better drying performance, the door will open automatically at the end of washing cycle. To protect the cabinet from corroding by the steam, please paste the protective tape which is provided as accessory before secure the dishwasher.

Refer to the installation instructions for more information.

# 8

## OPERATING INSTRUCTIONS

### 3 Delay

The **Delay** option allows you to automatically delay starting your dishwasher 1-12 hours.

To start the **Delay** option, press **Delay** until the desired delay time shows in the **Status** window. Press the **START/Cancel** button to start the delay option. If the delay option is interrupted, the **START/Cancel** button will have to be pressed again to return to delay option.

### 4 Status Window

The Status Window indicates the number of delay start hours, the number of minutes left in a cycle, and the CLOSE message.

When full cycle is complete, **✓COMPLETE** is illuminated.

When Sanitize is selected and achieved, **☼SANITIZED** is illuminated.

When Child Lock is activated, **🔒** is illuminated.

When rinse aid is insufficient, **☼** is illuminated.

This indicator is OFF as default, press and hold **Normal+Quick** to activate it.

### 5 START/Cancel Button

When cycle and options are selected, LEDs of selected cycle and options are illuminated. The status window displays the cycle time.

To start the cycle, press the **START/Cancel** button and immediately close the dishwasher door.

You can cancel a cycle anytime during the cycle. Press and hold the **START/Cancel** pad for 3 seconds.

The light above the cycle and option selected will go out, and the **START/Cancel** light will remain illuminated, the dishwasher will start a 60 second drain. At the end of the drain, select the next desired cycle. Press and hold the **Start/Cancel** pad for another 3 seconds to cancel the drain phase.

## Getting Started

1. Load Dishwasher (See Preparing and Loading Dishes).
2. Add detergent (See Dishwasher Dispenser & Detergents).
3. Add Rinse Aid, if needed (See Rinse Aid).
4. Run hot water faucet nearest dishwasher until water is hot. Turn water off.
5. Select desired **Cycle** (See Cycle Chart).
6. Select desired **Dry Option** (See Dry Option Selections).
7. To start, press **START/Cancel** pad and close door immediately.

## To Start a Cycle

When cycle and options are selected, LEDs of selected cycle and options are illuminated. The status window displays the cycle time and the LED above the **START/Cancel** button illuminates.

To start the cycle, press **START/Cancel** button and immediately close the dishwasher door.

The status window displays "CLOSE" after the **START/Cancel** button is pressed.

## To Cancel a Cycle and Delay Cycle

Both a running cycle and a delay cycle can be canceled at any time.

Open the dishwasher door and press the **START/Cancel** button until the cycle and option LEDs turn off. The running cycle or delay countdown is canceled.

Then the status window will display "60". If close the door immediately, the dishwasher will go into a 60-second draining phase.

Press and hold the **Start/Cancel** pad for another 3 seconds to cancel the drain phase.

## Opening the door during cycle

If you open the door while a cycle is running or delay is counting down, the dishwasher will stop running.

The LEDs of selected cycle and options are illuminated, the status window displays the remaining cycle time. The LED above **START/Cancel** button will blink to press start.

To resume, press **START/Cancel** button and close the dishwasher door immediately.

The status window displays "CLOSE " after the **START/Cancel** button is pressed.

## Status Window

The STATUS window, available on some models, indicates the following activity:

1h-12h.....	Number of delay start hours. The last hour will count down in minutes.
TIME .....	Number of time left in cycle .
CLOSE ....	Close door will scroll one time in the status window.

In the unlikely event that the dishwasher malfunctions, displays the error code "E1"(E2/E3/E4/Ed), or gives poor performance you can call the Frigidaire Customer Care Center at **1-800-944-9044**. They will be able to provide assistance in troubleshooting the problem and/or locating an authorized service technician, if needed.

## Status Indicator Lights

The console lights provide information about the cycle selection and current status. During operation, while the door is closed, these lights will remain on. At the completion of the cycle, the clean light will come on. The **Sanitized** light will also come on if that option was selected and sanitization was achieved during the wash cycle.

### White Light

The WHITE LIGHT in front of the console illuminates when the wash is complete.

### Blue Light

The BLUE LIGHT in front of the console illuminates to indicate that the wash cycle is operating.

# 10 OPERATING INSTRUCTIONS

The DishSense™ Technology checks the soil level on your dishes in the **Normal, Sanitize, Heavy cycles**. In response, automatic cycle adjustments are made to assure the dishware gets clean - with less food the cycle gets shorter. Cycle time will also vary based on the options selected and the incoming water temperature. **Not all cycles available on all models.**

## Cycle and Option Chart

Cycle	Available Options	Water (approx.)	Time *(Hours)
<b>Normal*</b> Recommended for lightly to heavily soiled loads.	<b>Drying:</b> NormalDry, MaxDry, Eco Air	2.7 - 5.6 gal. 10.1 - 21.1 L.	1½ - 2
<b>Sanitize*</b> Recommended for lightly to heavily soiled loads.	<b>Drying:</b> NormalDry, Eco Air	2.9-5.6 gal. 11-21.5 L.	1½ - 4/5
<b>Heavy*</b> Recommended for pots,pans, casseroles and dinnerware having light to heavily soiled loads.	<b>Drying:</b> NormalDry, MaxDry, Eco Air	2.9-5.6 gal. 11-18.2 L.	1½ -2¼
<b>Eco</b> Recommended for lightly soiled loads.	<b>Drying:</b> NormalDry, MaxDry, Eco Air	4.0 gal. 17.8 L.	1½
<b>Quick</b> Recommended for lightly soiled loads only.	<b>Drying:</b> NormalDry, Eco Air	15.3 L.	1

\* Cycle uses Soil Sensing feature to determine best Wash performance.

## Dish Preparation

Scrape away large pieces of food, bones, pits, toothpicks, etc. The continuously filtered wash fluid will remove remaining food particles. Burned-on foods should be loosened before loading. Empty liquids from glasses and cups.

Foods such as mustard, mayonnaise, vinegar, lemon juice and tomato based products may cause discoloration of stainless steel and plastics if allowed to sit for a long period of time. Unless the dishwasher is to be operated at once, it is best to pre-rinse to rinse off these food soils.

- Load racks so that large items do not prevent the detergent dispenser from opening.
- Check manufacturer's recommendations before washing items in question.
- If the dishwasher drains into a Food Disposer, **be sure disposer is completely empty before starting dishwasher.**

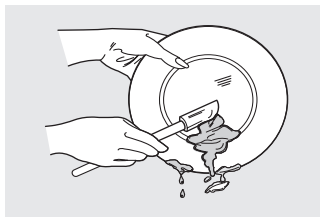

## Loading the Top Rack

**Features and appearance of racks and silverware basket as shown may vary from your model.**

The upper rack is designed for flexibility in loading a wide variety of items including cups, glasses, stemware, small plates, bowls, etc.

Load glasses in top rack only. Damage may occur if placed in bottom rack.

Load plastic items in top rack only. Melting may occur if placed in bottom rack.

Load items with open ends facing down for better cleaning and draining.

Damage may occur if delicate items touch each other during dishwasher operation.

Long-handled knives and utensils can be placed in top rack.

Be sure nothing protrudes through the bottom of the rack to block rotation of middle spray arm.

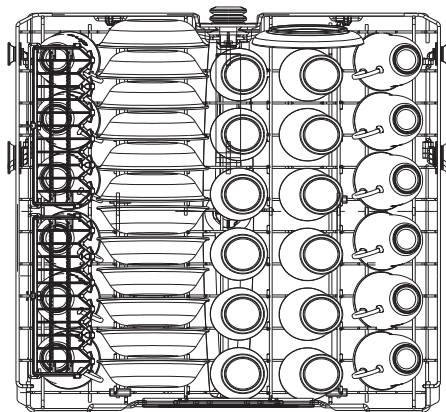

12 place settings standard loading pattern

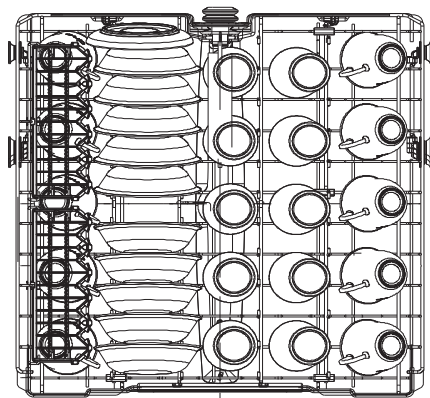

10 place settings standard loading pattern

Some models have a fold-down cup shelf or a cup shelf/stemware holder. They can be used to load two levels of cups, juice glasses, and other short items. Stagger items on upper level so that water can reach all inside surfaces. Fold up to load tall glasses.

# 12 CARE AND CLEANING

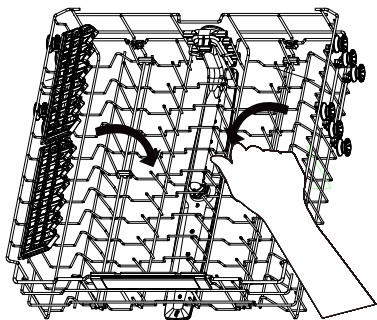

## Cup Shelves

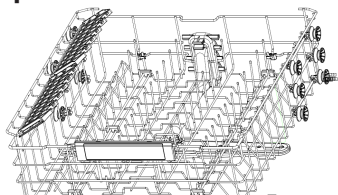

Cup shelves are used to load extra cups. Fold them down if not needed.

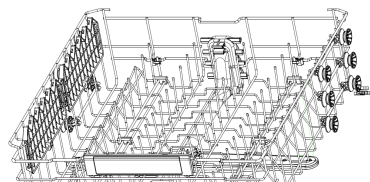

1. Lift the shelves up.

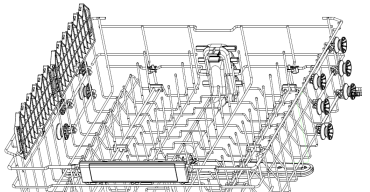

2. Flip the shelves to the right position.

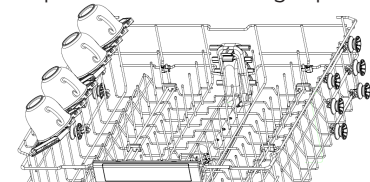

3. Load cups on the shelves.

## Adjustable Upper Rack

**IMPORTANT:**  
Remove all items before adjusting the rack. The rack must be empty.  
To adjust the height of the upper rack, follow these steps:

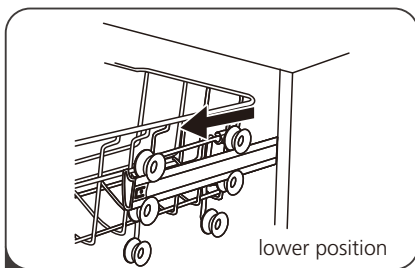

1 Pull out the upper basket.

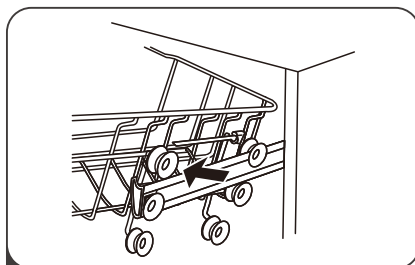

2 Remove the upper basket.

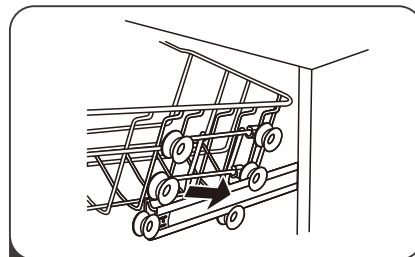

3 Re-attach the upper basket to upper or lower rollers.

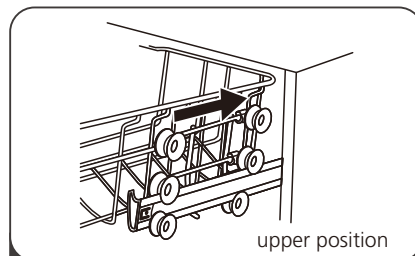

4 Push in the upper basket.

## Loading the Bottom Rack

**Features and appearance of racks and silverware basket as shown may vary from your model.**

The lower rack is best for plates, saucers, bowls, and cookware. Large items should be placed along the edge so they do not block the spray arm rotation. For best results, place bowls, casseroles, and sauce pans with soiled surface facing down and toward the center. Tilt slightly for better drainage.

Spin the middle spray arm to make sure that tall items do not block the rotation

Be sure pan handles do not protrude through the bottom of the rack and block the lower spray arm rotation.

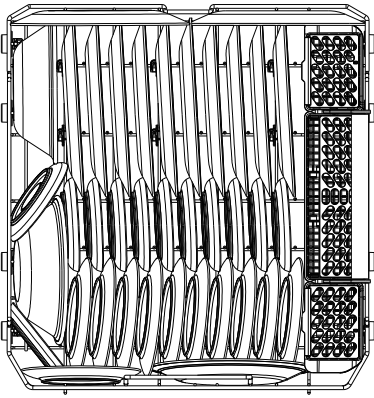

12 place settings standard loading pattern.

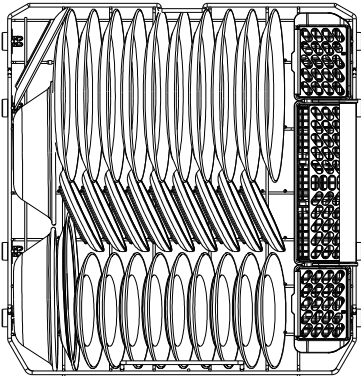

10 place settings standard loading pattern

## Fold-down Tines

The fold-down tines in the lower rack make easy loading for those extra large and hard-to-fit items. The tines may be left up for normal use or folded down for more flexible loading. Fold down for more space to load large pots or pans.

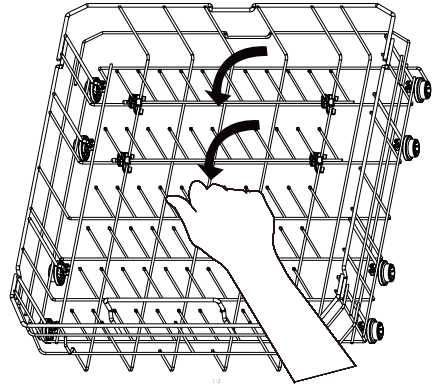

# 14 CARE AND CLEANING

## Loading the Silverware Basket



### CAUTION

Load sharp items (knives, skewers, etc.) pointing down.

Failure to do so may result in injury.

### Features and appearance of racks and silverware basket as shown may vary from your model.

Load the silverware basket while it is in the bottom rack or take the basket out for loading on a counter or table.

For baskets with lids, small items like baby bottle caps, jar lids, corn cob holders, etc., can be placed in a covered section to hold them in place.

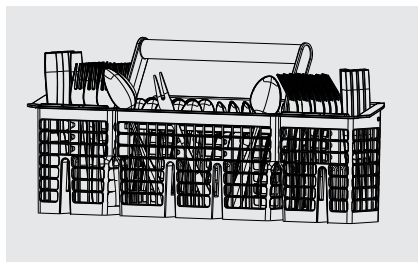

Use suggested loading patterns, as shown, to increase washability of the silverware.

### NOTE

Make sure the loaded items do not interfere with the rotation of the spray arm. Check this by rotating the spray arm by hand.

To avoid damaging the silver finish do not mix silver and stainless.

When covers are up, mix items in each section of the basket with some pointing up and some down to avoid nesting. Water spray cannot reach nested items.

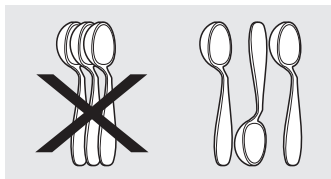

## THREE-PIECE SILVERWARE BASKET

The silverware basket consists of three separate sections. For optimum loading flexibility, the center section of the basket can be used individually, joined with one or both side sections or removed.

- Lift handle to remove the silverware basket and set the basket on a counter or table top.
- Lift up on each side section to disengage the center section from the keyhole slots in the side sections.
- Either replace the section(s) in the bottom rack and load the silverware, OR load the silverware while the section(s) are on the countertop and then replace the basket in the bottom rack.

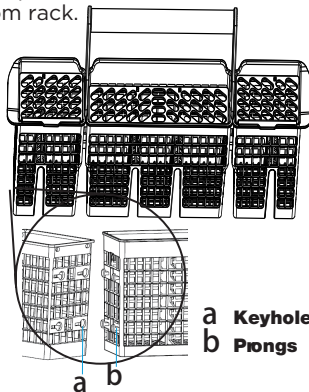

**a** Keyhole Slots  
**b** Prongs

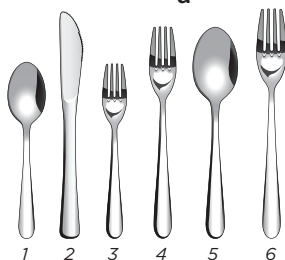

1. Cucharas
2. Cuchillos
3. Tenedores de ensalada
4. Tenedores
5. Cucharas de mesa
6. Tenedores de mesa

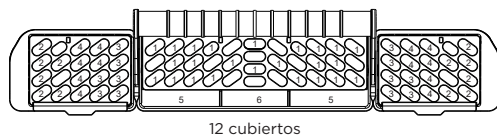
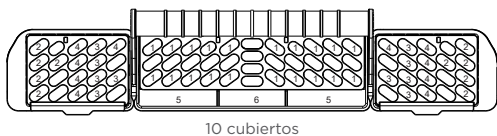

# CARE AND CLEANING 15

## Adding a Dish

To add or remove items after wash cycle starts:

- Unlatch door and wait a few seconds until wash action stops before opening.
- Add the item, move the door to a near-closed position, and wait a few seconds while the cold air slowly expands inside the dishwasher.
- Press the **START/Cancel** button then immediately close the door firmly to



## WARNING

Open the door very slowly & carefully if the dishwasher is operating. There is a risk of hot water squirting out.

## Filing the Detergent Dispenser

The detergent dispenser has two detergent cups. The smaller one is for addition to the pre-wash and the larger is for release to the main wash.

- Use only fresh automatic dishwashing detergent. Other detergents may cause oversudsing.
- When using automatic dishwashing detergent tablets or packets, use only one tablet or packet, place in the main wash cup and close.
- Add detergent just before starting cycle.
- Store detergent in a cool, dry location and discard any that becomes moist or caked.

1. Push the dispenser cover release catch to open the main wash detergent compartment.

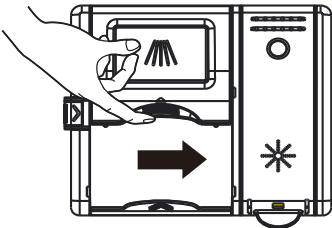

## NOTE:

The flap is always open at the end of a dishwashing cycle.

2. Add the recommended amount of detergent to the detergent compartment.

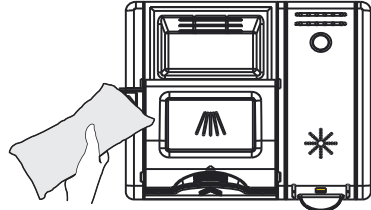

3. Press down on the top of the cover to secure.

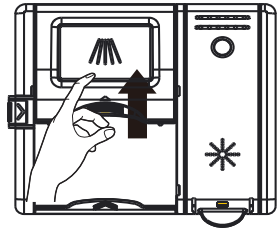

## How much Detergent to use

The amount of detergent to use depends on the soil level of your load, the type of detergent used and the hardness of your water.

- If you use too little detergent, dishes won't be clean.
- If you have soft water and use too much detergent, glassware will etch.

## Water Hardness

Water hardness varies depending on your water source. For the best results, your dishwasher is designed to operate with water that has a hardness of no more than 7 grains per gallon. Test kits are available from all major appliance parts retail outlets. If your water has a hardness over 8 grains per gallon, you may consider installing a water softener or regularly use an additive to enhance the performance of your detergent.



## CAUTION

The use of industrial grade detergent can damage the heating coil and other parts of the dishwasher leading to damage to the unit and surrounding property. Use only household grade automatic dishwasher detergents.

# 16 CARE AND CLEANING

## Rinse Aid

**Rinse aid greatly improves drying and reduces water spots.** With it water “sheets” off dishes rather than forming water droplets that cling and leave spots.

A dispenser, located next to the detergent cup, automatically releases a measured amount of rinse aid during the last

rinse. If spotting and poor drying are problems, increase the amount of rinse aid dispensed by below steps:

1. Open the door when dishwasher is in standby mode.
2. Within 60 seconds after opening the door, press and hold **Quick** button for more than 5 seconds to enter the set mode. The rinse aid indicator blinks.
3. Press **Quick** button again to select the proper set according to your using habits, the setting will change in the following sequence: 3→4→5→1→2→3. The higher the number, the more rinse aid the dishwasher uses.

4. Without operation in 5 seconds to complete the setup and exit the setting mode.

Under normal conditions, you will need to fill the rinse aid dispenser approximately once a month. Rinse aid is released through an opening in the dispenser. You do not need to wait until the dispenser is empty to refill it. Try to keep it full, but be careful not to overfill it.

## To refill the rinse aid dispenser

1. Lift up the end tab of rinse aid cover to open.

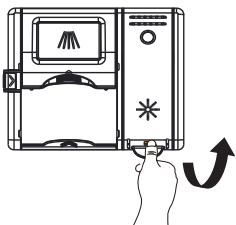

2. Fill the rinse aid dispenser with liquid rinse aid until full. DO NOT overfill.

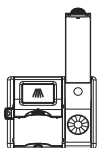

## NOTE:

Use the viewing port when filling the rinse aid reservoir.

## WARNING

Do not fill the reservoir above the full level indicator. Excess rinse aid can overflow during the wash cycle.

3. Press the rinse aid cover down firmly to close.

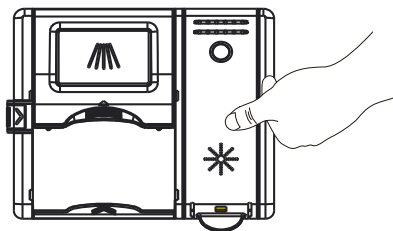

## Water Pressure

The hot water line to dishwasher must provide water pressure between 20 and 80 psi.

Low Water pressure may occur when laundry or showers are in operation. If you experience poor wash performance you may need to wait until water use is reduced before starting dishwasher.

## Water Temperature

Hot water is needed for best dishwashing and drying results. Water entering dishwasher should be at least 120°F to 150°F (49°C to 66°C) to give satisfactory results.

To check water temperature entering dishwasher:

- Turn on hot water faucet nearest dishwasher for several minutes to clear cool water from pipes.
- Hold a candy or meat thermometer in the water stream to check the temperature.
- If temperature is below 120° F (49° C), have a qualified person raise the hot water heater thermostat setting.



## IMPORTANT

Before starting a cycle, run hot water to clear cool water from pipe.

## CLEANING THE FILTERS

Check and clean the filters regularly for best performance.

1. Remove the lower dishwasher rack.
2. Rotate the Cylinder filter counterclockwise a quarter turn and lift up to remove.

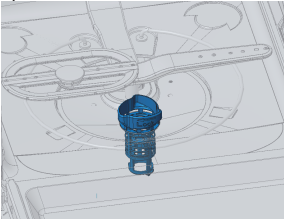

**(A) Cylinder Filter**

3. Empty the Cylinder filter and rinse it under running water.
4. Remove the Fine filter.

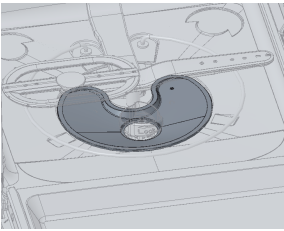

**(A) Fine Filter**

5. Remove the Micro filter from the bottom of the tub.

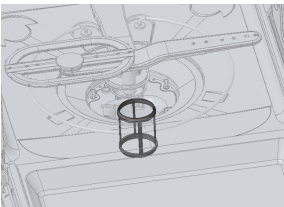

**(A) Micro Filter**

6. Inspect both the Fine filter and the Micro filter for debris, and then clean them by holding the filters under slow running water.

NOTE: A stiff, plastic bristle brush may be needed to remove some debris.

7. Reinstall the filters in reverse order making sure the Cylinder filter locks into place.



## WARNING



### Burn Hazard

Allow heating element to cool before cleaning the interior.

Failure to do so can result in burns.

**Outer Door** - Clean outer door with warm soapy water and a dishcloth or sponge. Rinse with clean water and a dry cloth. Do not use harsh cleaners.

**Inside** - The inside of the dishwasher and filter are self-cleaning with normal use. If needed, clean around the tub gasket area with a damp cloth. A glass trap located in the center of the filter is designed to collect pieces of broken glass, straws, bones and pits.



## NOTE

Hard water may cause lime deposit buildup on the interior of the dishwasher. For cleaning instructions see "Removing Spots and film" section.

# 18 CARE AND CLEANING

## Care of Drain Air Gap

If a drain air gap was installed for your built-in dishwasher, check to make sure it is clean so the dishwasher will drain properly. A drain air gap is usually mounted on countertop and can be inspected by removing the cover. This is not part of your dishwasher and is not covered by warranty.



### CAUTION

#### Property Damage Hazard

Freezing temperatures may cause water lines to rupture. Be sure all supply lines to and circulating lines within dishwasher are protected.

Failure to do so could result in property damage.



### NOTE

See Installation Instructions for more details on disconnecting and restoring service to your dishwasher.

## Winterizing

A dishwasher left in an unheated place should be protected from freezing. Have a qualified person do the following:

### To Disconnect Service:

1. Turn off electrical power to the dishwasher at the supply source by removing fuses or tripping circuit breaker.
2. Shut off water supply
3. Place a pan under the inlet valve. Disconnect water line from inlet valve and drain into pan.
4. Disconnect drain line from pump and drain water into pan.

### To Restore Service:

1. Direct water line discharge into a pan and open the valve to flush the line.
2. Reconnect the water, drain, and electrical power supply.
3. Turn on water and electrical power supply.
4. Fill both detergent cups and run dishwasher through a **Heavy Wash** cycle.
5. Check connections to make sure they do not leak.

Before calling for service, review this list. It may save you both time and expense. This list includes common experiences that are not the result of defective workmanship or material in your dishwasher.

## Food Soils Left on Dishes

- Choose another cycle for longer washing time.
- Check rack loading section for proper loading-avoid nesting items.
- Home water pressure may be too low-should be 20 to 80 pounds per square inch (psi).
- Check incoming water temperature. It should be about 120° F (49° C). (See Factors Affecting Performance.)
- Check water hardness. For extremely hard water, it may be necessary to install a water softener. (See Detergent Chart).
- Use Fresh Detergent.
- Make sure items are not blocking the spray arms, preventing them from rotating.
- Do not overload the dishwasher (See Preparing and Loading Dishes).
- Check to verify that the glass trap is maintained and installed properly (See Care and Cleaning).

## Dishes not Dry

- Select MaxDry or Eco Air dry option.
- Make sure the rinse aid dispenser is filled.
- Increase the discharge setting of rinse aid. (See Rinse Aid).
- Check the incoming water temperature. Be sure it is at least 120° F (49° C).
- Check for proper loading-avoid nesting items.
- Cups with a concave bottom will collect water. Load them at the far left and right of the upper rack so they will be held in a tilted position.

- Containers, bowls, pots/pans, and any dishware with concave surfaces that can collect water should be placed in the rack facing or angled down so that water is able to drain even from the lowest point.
- Plastic items may need to be towel dried.

## Glassware/Flatware Spotted or Cloudy

- Check water hardness. For extremely hard water, it may be necessary to install a water softener. (See Detergent Chart).
- Water temperature may be low. Avoid extremely low or high temperatures. (See Factors Affecting Performance).
- Avoid overloading and improper loading. (See Preparing and Loading Dishes).
- Use fresh detergent. Old detergent is ineffective.
- Make sure rinse aid dispenser is filled.
- Check to see that proper amount of detergent is being used for cycle selected. (See Detergent Dispenser).
- Home water pressure may be too low-it should be 20 to 80 pounds per square inch (psi).

## Dishware Chipped

- Load with care and do not overload. (See Preparing and Loading Dishes).
- Place delicate items in top rack.
- Place glasses securely against pins and not over pins.
- Load items so they are secure and don't jar loose when moving racks in and out. Move racks in and out slowly.
- Make sure tall glasses and stemware will clear top of tub when rack is pushed in.
- Fine antique china and crystal should be hand-washed.

# 20 TROUBLESHOOTING

## Dishware Stained or Discolored

- Tea and coffee can stain cups. Remove the stains by hand washing in a solution of 1/2 cup (120 ml) bleach and one quart (1L) of warm water. Rinse thoroughly.
- Iron deposits in water can cause a yellow or brown film. A special filter installed in the water supply line will correct this problem. **(See Removing Spots and Film).**
- Aluminum utensils can leave gray/black marks when they rub against other items. Load Properly.
- Certain high acid foods can cause discoloration of stainless steel and plastics if allowed to sit for a long period. Use the Rinse Only cycle or rinse by hand if not operating dishwasher at once.
- Mixing stainless steel and silver utensils in silverware basket can cause pitting of the stainless steel blades. Avoid mixing stainless steel and silver.

## Water in Bottom of Tub

- Water left in the tub bottom after the cycle is complete is not normal. If water remains in the bottom of the tub, the dishwasher may not be draining properly. **(See Dishwasher Does not Drain Properly).**

## Cycle Takes a Long Time

- The cycle may have been automatically lengthened to reach key temperatures due to some factor such as a cool water supply or a large load of dishes.
- Delay Start option may have been selected.
- Choose lower temperature options to shorten the cycle.
- Cycles that are soil-sensing adjust automatically to assure a good wash - heavier soils will elicit a longer cycle response.

## Etching

- Using too much detergent especially in soft or softened water causes damage that looks like a film but cannot be removed.
- Adjust the amount of detergent based on the water hardness. **(Check Detergent Chart).**
- Lower the water temperature by selecting one of the lower temperature options.

## Detergent Left in Cups

- Detergent may be old. Discard and use fresh detergent.
- Be sure the dish load doesn't block spray from entering the detergent cup.
- Check to see if cycle has been completed.
- Make sure items do not prevent the detergent dispenser from opening.

## Dishwasher Leaks

- Check that the door gasket is pressed into its mounting channel, reaches to the bottom of the tub and does not extend beyond the end rib so as to interfere with door closure.
- Spilled rinse aide can cause foam and lead to overflowing. Wipe up any spills with a damp cloth.
- Check to see that the dishwasher is level. **(See Installation Instructions).**
- Avoid oversudsing by using the correct amount of detergent designed for automatic dishwashers.
- Check to see that dishwasher is level. **(See Installation Instructions).**

## Normal Sounds You Will Hear

- Normal sounds include water fill, water spray, draining and motor sounds.
- There is a noticeable change in sound when the wash action switches between the lower and middle spray arm. This is normal since each spray arm has its own sound.
- It is normal for the dishwasher to pause (no sound) when the wash action is switching between the lower and middle spray arms.

### Dishwasher Won't Run

- Check to see if circuit breaker is tripped or if a fuse is blown.
- Make sure water supply is turned on.
- Check to see if cycle is set correctly. (See Operating Instructions).
- Is dishwasher set for Delay Start Option?
- Make sure **START/Cancel button** is pressed after cycle has been selected.
- Make sure door is closed and latched immediately after pressing the **START/Cancel button**

### Dishwasher Won't Fill

- Assure the water supply is turned on.
- Check that the overflow protector moves up and down freely. (**See Overflow Protector section**).

### Dishwasher Does Not Drain Properly

- If unit is hooked up to a food waste disposer, make sure the disposer is empty.
- Assure the knockout plug has been removed from inside the food waste disposer inlet.
- Assure the drain hose isn't kinked.
- Make sure cycle is complete, not in a pause.
- Assure the glass trap is maintained and installed properly assuring no clogs (**See Care and Cleaning**).

### Dishwasher has an Odor

- Soiled dishes left in dishwasher too long can create an odor.
- There will be a "new" smell when first installed. This is normal.
- Check to see if unit is draining properly. (**See Dishwasher Does Not Drain Properly**).

### Stains on Tub Interior

- Washing large amounts of dishware with tomato based soil can cause a pink/orange appearance. This will not affect performance and will gradually fade over time. Pre-rinsing will reduce the chance of staining. Using no heat dry option will lessen staining.

### Opening the door during cycle

- If the dishwasher door is opened while the unit is running, the **START/Cancel button** must be pressed and the door shut immediately to return the unit to the selected cycle and option, this must happen within 10 minutes for the unit to continue the cycle.

### Removing Spots and Film

Hard water can cause lime deposit buildup on the interior of the dishwasher. Dishes and glasses may also get spots and film for a number of reasons. (**See Glassware/Flatware Spotted or Cloudy section**). To remove buildup, and film, clean using the following instructions:

1. Load clean dishes and glasses in normal manner. Do not load any metal utensils or silverware.
2. Do not add detergent.
3. Select the NORMAL cycle. Press **START/Cancel button**. Close the door.
4. Allow dishwasher to run until it starts the second water fill (approximately 8 minutes).
5. Open the door, pour 2 cups of white vinegar into the bottom of dishwasher.
6. Press **START/Cancel button**. Close the door and allow cycle to finish.

# 22

## Error code and description

When error occurs, press Normal+Sanitize+Delay to power off and reset the dishwasher.

Error code	When occur	Symptom	Possible Causes
E1	When the non-water switch work in wash step at Pre-wash phase.	All driving parts except for the drain part are turned off and draining is performed for 120 seconds.(without retry)	The water supply pressure is low. The water supply valve is closed. the non-water switch is broken. the wash pump doesn't work. The Main PBA has some problems.
E2	When the high-water float switch is on for 5 seconds in 5 times. When the high water float switch is on for 120 seconds.	All driving parts except for the drain part are turned off and draining is performed for 120 seconds.(without retry)	The high-water float switch is broken. The water value is always open(It cannot be closed). The Main PBA has some problems.
E3	When the heating continually for 60 minutes,yet still not arrive the anticipated temperature.	All driving parts except for the drain part are turned off and draining is performed for 120 seconds.(without retry)	The heater is broken. The thermistor doesn't work normally. The Main PBA has some problems.
E4	When the water leakage sensor date is equal to less than 3V for 2 seconds.	All driving parts except for the drain part are turned off and draining is performed for 120 seconds.(without retry)	The case brake fails to detect the pulse. The valve water is out of order. The overflow sensor is broken. There is a water leakage.
E6	When the thermistor is under open-circuit failure.	All driving parts except for the drain part are turned off and draining is performed for 120 seconds.(without retry)	The Thermistor is broken. The main PBA fails to detect the pulse.
E7	When the thermistor is under short-circuit failure.	All driving parts except for the drain part are turned off and draining is performed for 120 seconds.(without retry)	The Thermistor is broken. The main PBA fails to detect the pulse.
E8	The orientation of the distributary valve not working.	All driving parts except for the drain part are turned off and draining is performed for 120 seconds.(without retry)	The wire is not connected correctly, or the distributary valve is broken.
Ed	When communications between the main PBA and the sub PBA fails for 20 seconds	Keep going remained cycle	The main PBA or sub PBA is out of order. The communications connection for the main PBA or sub PBA is not properly connected.

Your appliance is covered by a one year limited warranty. For one year from your original date of purchase, Electrolux will pay all costs for repairing or replacing any parts of this appliance that prove to be defective in materials or workmanship when such appliance is installed, used and maintained in accordance with the provided instructions.

## Exclusions

### This warranty does not cover the following:

1. Products with original serial numbers that have been removed, altered or cannot be readily determined.
2. Product that has been transferred from its original owner to another party or removed outside the USA or Canada.
3. Rust on the interior or exterior of the unit.
4. Products purchased "as-is" are not covered by this warranty.
5. Food loss due to any refrigerator or freezer failures.
6. Products used in a commercial setting.
7. Service calls which do not involve malfunction or defects in materials or workmanship, or for appliances not in ordinary household use or used other than in accordance with the provided instructions.
8. Service calls to correct the installation of your appliance or to instruct you how to use your appliance.
9. Expenses for making the appliance accessible for servicing, such as removal of trim, cupboards, shelves, etc., which are not a part of the appliance when it is shipped from the factory.
10. Service calls to repair or replace appliance light bulbs, air filters, water filters, other consumables, or knobs, handles, or other cosmetic parts.
11. Surcharges including, but not limited to, any after hour, weekend, or holiday service calls, tolls, ferry trip charges, or mileage expense for service calls to remote areas, including the state of Alaska.
12. Damages to the finish of appliance or home incurred during installation, including but not limited to floors, cabinets, walls, etc.
13. Damages caused by: services performed by unauthorized service companies; use of parts other than genuine Electrolux parts or parts obtained from persons other than authorized service companies; or external causes such as abuse, misuse, inadequate power supply, accidents, fires, or acts of God.

## DISCLAIMER OF IMPLIED WARRANTIES; LIMITATION OF REMEDIES

CUSTOMER'S SOLE AND EXCLUSIVE REMEDY UNDER THIS LIMITED WARRANTY SHALL BE PRODUCT REPAIR OR REPLACEMENT AS PROVIDED HEREIN. CLAIMS BASED ON IMPLIED WARRANTIES, INCLUDING WARRANTIES OF MERCHANTABILITY OR FITNESS FOR A PARTICULAR PURPOSE, ARE LIMITED TO ONE YEAR OR THE SHORTEST PERIOD ALLOWED BY LAW, BUT NOT LESS THAN ONE YEAR. ELECTROLUX SHALL NOT BE LIABLE FOR CONSEQUENTIAL OR INCIDENTAL DAMAGES SUCH AS PROPERTY DAMAGE AND INCIDENTAL EXPENSES RESULTING FROM ANY BREACH OF THIS WRITTEN LIMITED WARRANTY OR ANY IMPLIED WARRANTY. SOME STATES AND PROVINCES DO NOT ALLOW THE EXCLUSION OR LIMITATION OF INCIDENTAL OR CONSEQUENTIAL DAMAGES, OR LIMITATIONS ON THE DURATION OF IMPLIED WARRANTIES, SO THESE LIMITATIONS OR EXCLUSIONS MAY NOT APPLY TO YOU. THIS WRITTEN WARRANTY GIVES YOU SPECIFIC LEGAL RIGHTS. YOU MAY ALSO HAVE OTHER RIGHTS THAT VARY FROM STATE TO STATE.

## If You Need Service

Keep your receipt, delivery slip, or some other appropriate payment record to establish the warranty period should service be required. If service is performed, it is in your best interest to obtain and keep all receipts. Service under this warranty must be obtained by contacting Electrolux at the addresses or phone numbers below.

This warranty only applies in the USA and Canada. In the USA, your appliance is warranted by Electrolux Major Appliances North America, a division of Electrolux Home Products, Inc. In Canada, your appliance is warranted by Electrolux Canada Corp. Electrolux authorizes no person to change or add to any obligations under this warranty. Obligations for service and parts under this warranty must be performed by Electrolux or an authorized service company. Product features or specifications as described or illustrated are subject to change without notice.

**USA**  
**1-800-374-4432**  
Frigidaire  
10200 David Taylor Drive  
Charlotte, NC 28262



**Electrolux**

**Canada**  
**1.800.265.8352**  
Electrolux Canada Corp.  
5855 Terry Fox Way  
Mississauga, Ontario, Canada  
L5V 3E4

# FRIGIDAIRE®

welcome *home*

Our home is your home. Visit us if you need help with any of these things:



owner support



accessories



service



registration

(See your registration card for more information.)

Frigidaire.com  
1-800-374-4432

Frigidaire.ca  
1-800-265-8352