

# FRIGIDAIRE

All about the

# Use & Care

of your Freezer

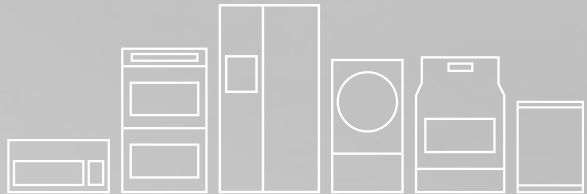

## TABLE OF CONTENTS

Important Safety Instructions.....	2	Storing Food and Saving Energy.....	7
Installation .....	4	Care and Cleaning .....	8
Controls and Settings .....	5	Troubleshooting .....	10
Storage Features.....	6	Warranty .....	11

# IMPORTANT SAFETY INSTRUCTIONS



## WARNING

Please read all instructions before using this unit.

## Definitions

 This is the safety alert symbol. It is used to alert you to potential personal injury hazards. Obey all safety messages that follow this symbol to avoid possible injury or death.



## DANGER

DANGER indicates an imminently hazardous situation which, if not avoided, will result in death or serious injury.



## WARNING

WARNING indicates a potentially hazardous situation which, if not avoided, could result in death or serious injury.



## CAUTION

CAUTION indicates a potentially hazardous situation which, if not avoided, may result in minor or moderate injury.



## IMPORTANT

IMPORTANT indicates installation, operation or maintenance information which is important but not hazard-related.



## DANGER



DANGER-Risk of fire or explosion. Flammable refrigerant used. Do not use mechanical devices to defrost refrigerator. Do not puncture refrigerant tubing.

DANGER-Risk of fire or explosion. Flammable refrigerant used. To be repaired only by trained service personnel. Do not puncture refrigerant tubing.



## CAUTION



CAUTION-Risk of fire or explosion. Flammable refrigerant used. Consult repair manual/owner's guide before attempting to service this product. All safety precautions must be followed.

CAUTION-Risk of fire or explosion. Dispose of property in accordance with federal or local regulations. Flammable refrigerant used.

CAUTION-Risk of fire or explosion due to puncture refrigerant tubing. Follow handling instructions carefully. Flammable refrigerant used.



## WARNING

WARNING! CALIFORNIA RESIDENTS  
Cancer and Reproductive Harm  
[www.P65Warnings.ca.gov](http://www.P65Warnings.ca.gov)

## For Your Safety

- Do not store or use gasoline or other flammable vapors and liquids in the vicinity of this unit or any other appliance. Read product labels for flammability and other warnings.
- Do not operate the unit in the presence of explosive fumes.
- Remove and discard any spacers used to secure the shelves during shipping. Small objects are a choke hazard to children.
- Remove all staples from the carton. Staples can cause severe cuts, and also destroy finishes if they come in contact with other appliances or furniture.

## Child Safety

- This appliance is not intended for use by persons (including children) with reduced physical, sensory or mental capabilities, or lack of experience and knowledge, unless they have been given supervision or instruction concerning use of the appliance by a person responsible for their safety.
- Destroy or recycle the carton, plastic bags, and any exterior wrapping material immediately after the Appliance is unpacked. Children should never use these items to play. Cartons covered with rugs, bedspreads, plastic sheets or stretch wrap may become airtight chambers, and can quickly cause suffocation.

# IMPORTANT SAFETY INSTRUCTIONS

- An empty, discarded appliance is a very dangerous attraction to children.
- Remove the door(s) of any appliance that is not in use, even if it is being discarded.

## Proper Disposal of Your Appliance

### Risk of child entrapment

Child entrapment and suffocation are not problems of the past. Junked or abandoned appliances are still dangerous – even if they will sit for “just a few days”. If you are getting rid of your old appliance, please follow the instructions below to help prevent accidents.

We strongly encourage responsible appliance recycling/disposal methods. Check with your utility company or visit [www.recyclemyoldfridge.com](http://www.recyclemyoldfridge.com) for more information on recycling your old appliance.

### Before you throw away your old appliance:

- Remove door/lid.
- Leave shelves in place so children may not easily climb inside.
- Have the refrigerant removed by a qualified technician.

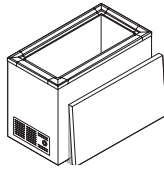

## WARNING

Avoid fire hazard or electric shock. Do not use an extension cord or an adapter plug. Do not remove any prong from power cord.

Grounding type wall receptacle

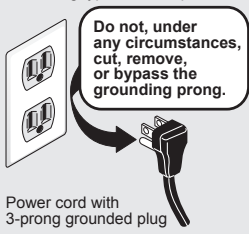

Power cord with 3-prong grounded plug

## Electrical Information

These guidelines must be followed to ensure that safety mechanisms in the design of this appliance will operate properly.

- Refer to the serial plate for correct electrical rating. The power cord of the appliance is equipped with a 3-prong grounding plug for your protection against electrical shock hazards. It must be plugged directly into a properly grounded three-prong receptacle, protected with a 15-amp time delay fuse or circuit breaker. The receptacle must be installed in accordance with the local codes and ordinances. Consult a qualified electrician. Receptacles protected by Ground Fault Circuit Interrupters (GFCI) are NOT RECOMMENDED. Do NOT use an extension cord or adapter plug.
- Never unplug the appliance by pulling on the power cord. Always grip the plug firmly, and pull straight out from the receptacle to prevent damaging the power cord.
- Unplug the appliance before cleaning to avoid electrical shock.
- If voltage varies by 10% or more, appliance performance may be affected. Operating the unit with insufficient power can damage the motor. Such damage is not covered under the warranty. If you suspect your household voltage is high or low, consult your power company for testing.
- To prevent the appliance from being turned off accidentally, do not plug unit into an outlet controlled by a wall switch or pull cord.
- Do not pinch, knot, or bend power cord in any manner.

# INSTALLATION

This Use & Care Guide provides general operating instructions for your model. Use the unit only as instructed in this Use & Care Guide.

**Before starting the unit, follow these important first steps.**

## Location

Choose a place that is near a grounded electrical outlet.

For the most efficient operation, the appliance should be located where surrounding temperatures will not exceed 110°F (43°C). Temperatures of 32°F (0°C) and below will NOT affect operation. Additional compressor heaters are not recommended.

Allow space around the unit for good air circulation. Leave a 4 inch (101.6 mm) space on all sides of the unit for adequate circulation.

## Leveling (optional)

### NOTE

It is VERY IMPORTANT for your freezer to be level in order to function properly. If the unit is not leveled during installation, the lid may be misaligned and not close or seal properly, causing cooling, frost, or moisture problems.

Use the leveling legs (located on the left side, front and rear) to ensure that all 4 corners of the freezer are resting firmly on a solid floor. Turn the leveling legs clockwise to retract the legs and counterclockwise to extend the legs. Ensure the floor is strong enough to support a fully loaded freezer.

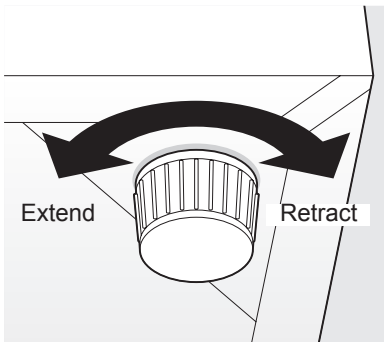

## Cleaning

- Wash any removable parts of the appliance interior and exterior with mild detergent and warm water. Wipe dry. **DO NOT USE HARSH CLEANERS ON THESE SURFACES.**
- Do not use razor blades or other sharp instruments which can scratch the appliance surface when removing adhesive labels. Any glue left from the tape can be removed with a mixture of warm water and mild detergent or the residue can be touched with the sticky side of tape already removed. **DO NOT REMOVE THE SERIAL LABEL.**

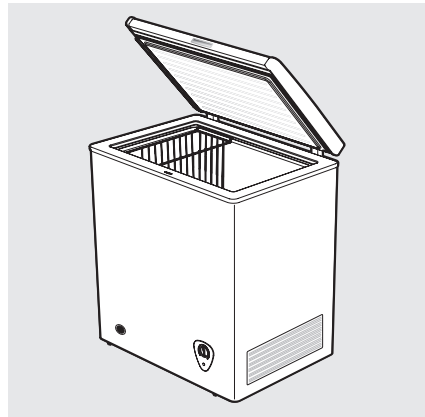

# CONTROLS AND SETTINGS

## Cool Down Period

- For safe food storage, allow 4 hours for the appliance to cool down completely. The unit will run continuously for the first several hours. Foods that are already frozen may be placed in the unit after the first few hours of operation. Unfrozen foods should **NOT** be loaded into the appliance until the unit has operated for 4 hours.
- When loading the unit, freeze only 3 pounds of fresh food per cubic foot of freezer space at one time. Distribute packages to be frozen evenly throughout the appliance. It is not necessary to turn control knob to a colder setting while freezing food.

## Temperature Control

The temperature control is located on the front outside wall. The temperature control is adjustable to provide a range of temperatures for your personal satisfaction. The temperature is factory preset to Mid setting to provide satisfactory food storage temperatures. If a colder temperature is desired, turn the temperature control knob toward **Coldest** and allow 24 hours for temperatures to stabilize between adjustments.

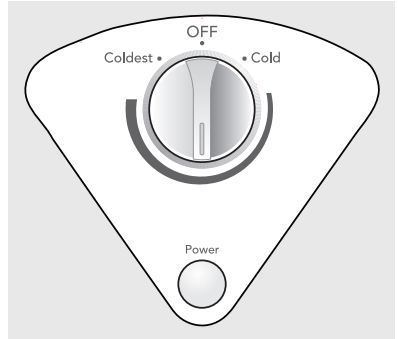

# STORAGE FEATURES

## **Defrost Drain**

The defrost drain provides a method of draining the water during defrosting and cleaning. See "Defrosting" in **CARE AND CLEANING** section.

## **Power On Light**

The Power On Light indicates that the appliance is properly connected to electrical power. The light glows even when the temperature control is turned to OFF. If the light goes out, refer to "Appliance does not run" in the **TROUBLESHOOTING** section.

## STORING FOOD AND SAVING ENERGY



- The appliance should be located in the coolest area of the room, away from heat producing appliances or heating ducts, and out of direct sunlight.
- Let hot foods cool to room temperature before placing in the unit. Overloading the appliance forces the compressor to run longer. Foods that freeze too slowly may lose quality or spoil.
- Be sure to wrap foods properly and wipe containers dry before placing them in the unit. This cuts down on frost build-up inside the appliance.
- The unit should not be lined with aluminum foil, wax paper, or paper toweling. Liners interfere with cold air circulation, making the appliance less efficient.
- Organize and label food to reduce door openings and extended searches. Remove as many items as needed at one time, and close door as soon as possible.

# CARE AND CLEANING



## CAUTION

Damp objects stick to cold metal surfaces. Do not touch interior metal surfaces with wet or damp hands.

## Between Defrostings

To avoid frequent defrosting, occasionally use a plastic scraper to remove frost. Scrape with a pulling motion. Never use a metal instrument to remove frost.



## CAUTION

Appliance must be unplugged (to avoid electrical hazard) from power source when cleaning unit.

## Other Precautions

- To defrost appliance, always unplug unit first.
- Never unplug the unit by pulling on the power cord. Always grip the plug firmly and pull straight out from the receptacle.
- Turning the control to OFF turns off the compressor, but does not disconnect power to other electrical components.

## Defrosting

It is important to defrost and clean the appliance when  $\frac{1}{4}$  to  $\frac{1}{2}$  inch of frost has accumulated. Frost may tend to accumulate faster on the upper part of the unit due to warm, moist air entering the appliance when the door is opened. Remove food and leave the door open when defrosting the unit.

If the frost is soft, remove it by using a plastic scraper. If the frost is glazed and hard, fill deep pans with hot water and place them on the appliance bottom. Close the door. Frost should soften in about 15 minutes. Place towels or newspapers on the bottom to catch the frost. The frost will loosen and fall. Remove towels and/or newspapers. Repeat this procedure if necessary.

Unscrew the drain plug inside the unit, and unscrew the outside defrost drain plug. Place a shallow pan under the drain tube. Defrost water will drain out. Check pan occasionally so water does not overflow. Replace the drain plugs when defrosting and cleaning are completed.

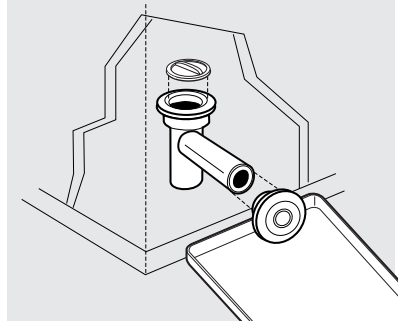

## Cleaning the Inside

After defrosting, wash inside surfaces of the appliance with a solution of 2 tablespoons of baking soda in 1 quart (1.136 litres) warm water. Rinse and dry. Wring excess water out of the sponge or cloth when cleaning in the area of the controls, or any electrical parts.

Wash the removable parts with the baking soda solution mentioned above, or mild detergent and warm water. Rinse and dry. **Never** use metallic scouring pads, brushes, abrasive cleaners, or alkaline solutions on any surface. Do not wash removable parts in a dishwasher.

## Cleaning the Outside

Wash the cabinet with warm water and mild liquid detergent. Rinse well and wipe dry with a clean soft cloth. Replace parts and food.

## Vacation and Moving Tips

**Short Vacations:** Leave the unit operating during vacations of less than 3 weeks.

**Long Vacations:** If the appliance will not be used for several months, remove all food and unplug the power cord. Clean and dry the interior thoroughly. To prevent odor and mold growth, leave the door open slightly, blocking it open if necessary.

**Moving:** Disconnect the power cord plug from the wall outlet. Remove food, defrost, and then clean the unit. Secure all loose items such as base panel, baskets, and shelves by taping them securely in place to prevent damage. In the moving vehicle, secure the appliance to prevent movement. Also protect outside of the unit with a blanket, or similar item. Do not place heavy items on the lid as this may damage or deform the lid resulting in a bad seal.



### WARNING

If leaving appliance door open while on vacation, make certain that children cannot get into the unit and become entrapped.



### NOTE

Do not open appliance door unnecessarily if unit is off for several hours.

**If a power failure occurs,** frozen foods will stay frozen for at least 24 hours if the unit is kept closed. If the power failure continues, pack seven or eight pounds of dry ice into the appliance every 24 hours. Always wear gloves and use caution when handling dry ice. To locate dry ice suppliers search for "Dry Ice", "Dairies" or "Ice Cream Manufacturers".

# TROUBLESHOOTING

PROBLEM	CAUSE	CORRECTION
<b>APPLIANCE OPERATION</b>		
<b>Appliance does not run.</b>	<ul style="list-style-type: none"> <li>• Appliance is plugged into a circuit that has a ground fault interrupt.</li> <li>• Temperature Control is in the OFF position.</li> <li>• Appliance may not be plugged in or plug may be loose.</li> <li>• House fuse blown or tripped circuit breaker.</li> <li>• Power outage</li> </ul>	<ul style="list-style-type: none"> <li>• Use another circuit. If you are unsure about the outlet, have it checked by a certified technician.</li> <li>• See <b>CONTROLS AND SETTINGS</b> Control section.</li> <li>• Ensure plug is tightly pushed into outlet.</li>   <li>• Check/replace fuse with a 15-amp time delay fuse. Reset circuit breaker.</li> <li>• Check house lights. Call a qualified electrician.</li> </ul>
<b>Interior temperature is too cold.</b>	<ul style="list-style-type: none"> <li>• The temperature is set too low.</li> </ul>	<ul style="list-style-type: none"> <li>• Turn control to a warmer setting.</li> </ul>
<b>Interior temperature is too warm.</b>	<ul style="list-style-type: none"> <li>• Temperature Control is set too warm.</li> <li>• Lid is kept open too long or is opened too frequently.</li> <li>• Large amounts of warm or hot food may have been stored recently.</li> <li>• Appliance has recently been disconnected for a period of time.</li> </ul>	<ul style="list-style-type: none"> <li>• Turn control to a colder setting. Allow 24 hours for the temperature to stabilize.</li> <li>• Warm air enters the appliance every time the lid is opened. Open the lid less often.</li>   <li>• Wait until the appliance has had a chance to reach its selected temperature.</li>   <li>• Appliance requires 24 hours to cool down completely.</li> </ul>
<b>SOUND AND NOISE</b>		
<b>Vibrating or rattling noise.</b>	<ul style="list-style-type: none"> <li>• Appliance is not level. It rocks on the floor when it is moved slightly.</li> <li>• Floor is uneven or weak. Appliance rocks on floor when it is moved slightly.</li> </ul>	<ul style="list-style-type: none"> <li>• Level the unit. Refer to “Leveling” in the <b>INSTALLATION</b>.</li>   <li>• Ensure floor can adequately support appliance. Level the appliance by putting wood or metal shims under part of the appliance.</li> </ul>
<b>WATER/MOISTURE/FROST INSIDE APPLIANCE</b>		
<b>Moisture forms on inside walls.</b>	<ul style="list-style-type: none"> <li>• Weather is hot and humid, which increases internal rate of frost build-up.</li> <li>• Lid may not be seating properly.</li>   <li>• Lid is kept open too long, or is opened too frequently.</li> </ul>	<ul style="list-style-type: none"> <li>• This is normal.</li>   <li>• Carefully warm the leaking sections of the door seal with a hair dryer set on “cool”. Simultaneously shape the warmed door seal by hand so that it seats correctly.</li> <li>• Open the lid less often.</li> </ul>
<b>LIGHT BULB IS NOT ON</b>		
<b>Power Available Light is not on</b>	<ul style="list-style-type: none"> <li>• LED may be burned out.</li> <li>• No electric current is reaching the freezer.</li> </ul>	<ul style="list-style-type: none"> <li>• Contact a qualified service dealer.</li> <li>• See “Appliance does not run” in the <b>APPLIANCE OPERATION</b> Section.</li> </ul>

Your appliance is covered by a one year limited warranty. For one year from your original date of purchase, Electrolux will pay all costs for repairing or replacing any parts of this appliance that prove to be defective in materials or workmanship when such appliance is installed, used and maintained in accordance with the provided instructions.

## Exclusions

### This warranty does not cover the following:

1. Products with original serial numbers that have been removed, altered or cannot be readily determined.
2. Product that has been transferred from its original owner to another party or removed outside the USA or Canada.
3. Rust on the interior or exterior of the unit.
4. Products purchased "as-is" are not covered by this warranty.
5. Food loss due to any Appliance or freezer failures.
6. Products used in a commercial setting.
7. Service calls which do not involve malfunction or defects in materials or workmanship, or for appliances not in ordinary household use or used other than in accordance with the provided instructions.
8. Service calls to correct the installation of your appliance or to instruct you how to use your appliance.
9. Expenses for making the appliance accessible for servicing, such as removal of trim, cupboards, shelves, etc., which are not a part of the appliance when it is shipped from the factory.
10. Service calls to repair or replace appliance light bulbs, air filters, water filters, other consumables, or knobs, handles, or other cosmetic parts.
11. Surcharges including, but not limited to, any after hour, weekend, or holiday service calls, tolls, ferry trip charges, or mileage expense for service calls to remote areas, including the state of Alaska.
12. Damages to the finish of appliance or home incurred during installation, including but not limited to floors, cabinets, walls, etc.
13. Damages caused by: services performed by unauthorized service companies; use of parts other than genuine Electrolux parts or parts obtained from persons other than authorized service companies; or external causes such as abuse, misuse, inadequate power supply, accidents, fires, or acts of God.

## DISCLAIMER OF IMPLIED WARRANTIES; LIMITATION OF REMEDIES

CUSTOMER'S SOLE AND EXCLUSIVE REMEDY UNDER THIS LIMITED WARRANTY SHALL BE PRODUCT REPAIR OR REPLACEMENT AS PROVIDED HEREIN. CLAIMS BASED ON IMPLIED WARRANTIES, INCLUDING WARRANTIES OF MERCHANTABILITY OR FITNESS FOR A PARTICULAR PURPOSE, ARE LIMITED TO ONE YEAR OR THE SHORTEST PERIOD ALLOWED BY LAW, BUT NOT LESS THAN ONE YEAR. ELECTROLUX SHALL NOT BE LIABLE FOR CONSEQUENTIAL OR INCIDENTAL DAMAGES SUCH AS PROPERTY DAMAGE AND INCIDENTAL EXPENSES RESULTING FROM ANY BREACH OF THIS WRITTEN LIMITED WARRANTY OR ANY IMPLIED WARRANTY. SOME STATES AND PROVINCES DO NOT ALLOW THE EXCLUSION OR LIMITATION OF INCIDENTAL OR CONSEQUENTIAL DAMAGES, OR LIMITATIONS ON THE DURATION OF IMPLIED WARRANTIES, SO THESE LIMITATIONS OR EXCLUSIONS MAY NOT APPLY TO YOU. THIS WRITTEN WARRANTY GIVES YOU SPECIFIC LEGAL RIGHTS. YOU MAY ALSO HAVE OTHER RIGHTS THAT VARY FROM STATE TO STATE.

## If You Need Service

Keep your receipt, delivery slip, or some other appropriate payment record to establish the warranty period should service be required. If service is performed, it is in your best interest to obtain and keep all receipts. Service under this warranty must be obtained by contacting Electrolux at the addresses or phone numbers below.

This warranty only applies in the USA and Canada. In the USA, your appliance is warranted by Electrolux Major Appliances North America, a division of Electrolux Home Products, Inc. In Canada, your appliance is warranted by Electrolux Canada Corp. Electrolux authorizes no person to change or add to any obligations under this warranty. Obligations for service and parts under this warranty must be performed by Electrolux or an authorized service company. Product features or specifications as described or illustrated are subject to change without notice.

## USA

1-800-374-4432

Frigidaire

10200 David Taylor Drive  
Charlotte, NC 28262



Electrolux

## Canada

1-800-265-8352

Electrolux Canada Corp.

5855 Terry Fox Way  
Mississauga, Ontario, Canada  
L5V 3E4