

*Frigidaire*

## Factory Parts Catalog

Product No.	AFFC1466DW0
Series	134A
Color	white
Volts	115
Wiring Diagram	216993300
Owner's Guide	216993100
Market	North America
Energy Guide	216993200

 **Electrolux**

ELECTROLUX HOME PRODUCTS, INC.  
P.O. Box 212378, Augusta, GA 30917

Publication No.  
**5995416293**  
04/09/14  
(EN/SERVICE/MLR)  
365

### **FREEZER CHEST**

Model No.  
**AFFC1466DW**

Copyright © 2004 Electrolux Home Products, Inc.  
All rights reserved.

DOOR

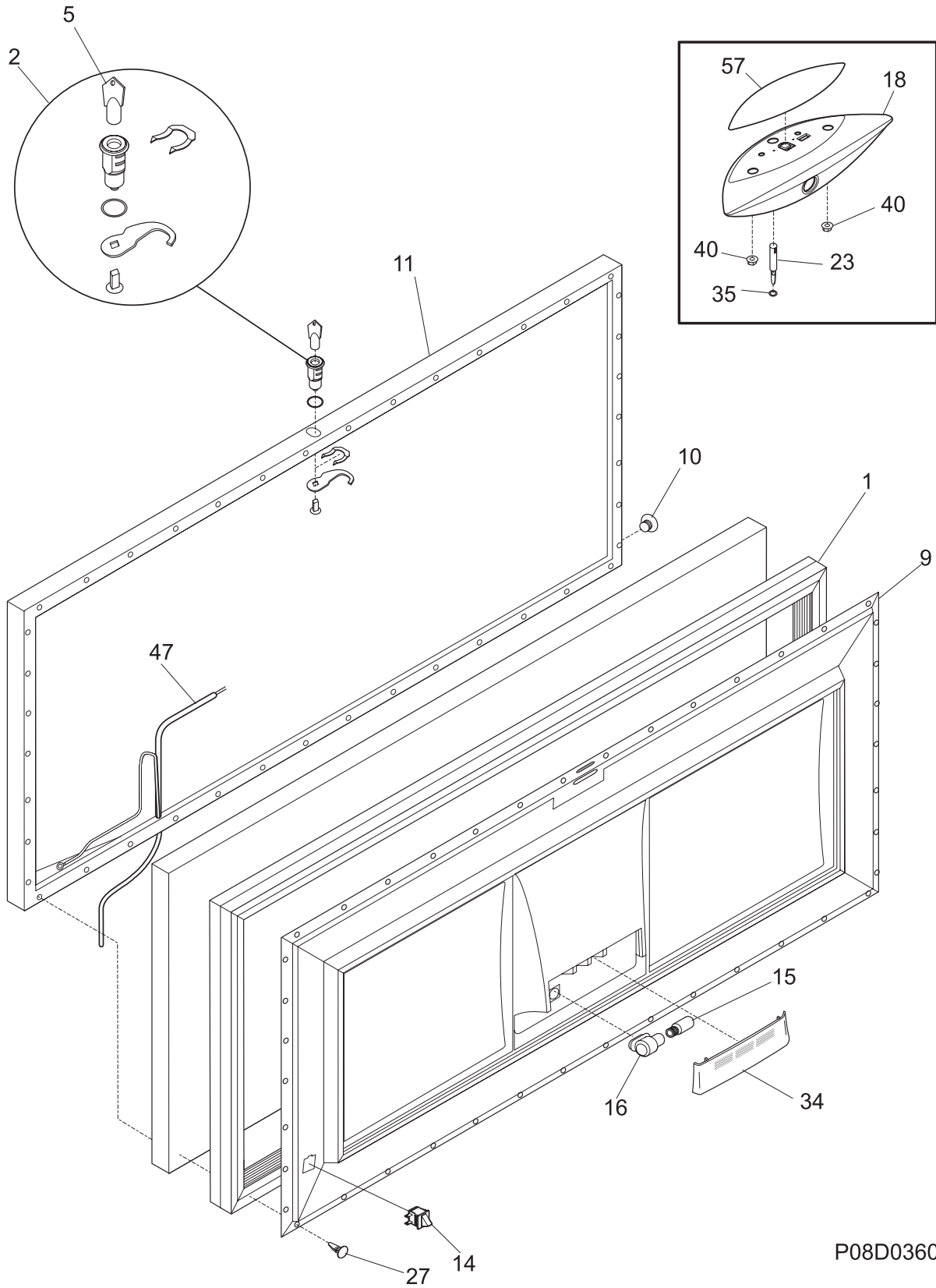

P08D0360

---

**DOOR**

---

POS. NO	PART NO.	DESCRIPTION
1	216481201	Gasket-door, white
2	5303925107	Lock Assy
*	5303313518	Washer, sealing
5 #	216702900	Key, lock
9	216829104	Panel-lid
10	216923001	Plug button, 1/4", white
11	216129932	Lid, white
*	5303161215	Screw, ph truss head, 8-18AB x 0.500
14	216822900	Switch, light/lamp, ramp
15	216846400	Light Bulb/Lamp
16	216817600	Socket, light/lamp, 25 W
18	216897600	Handle, white
23	216212700	Light-signal, amber
27	5303212828	Clip, panel mtg
34	216578504	Shield-light
35	216205400	Washer, signal light
40	216922700	Fastener, .330 dia stud, handle, (2)
47 #	216908000	Harness-lid
57	216899508	Overlay
*	5303917276	Insulation-door, fiberglass, (bulk)

### CABINET

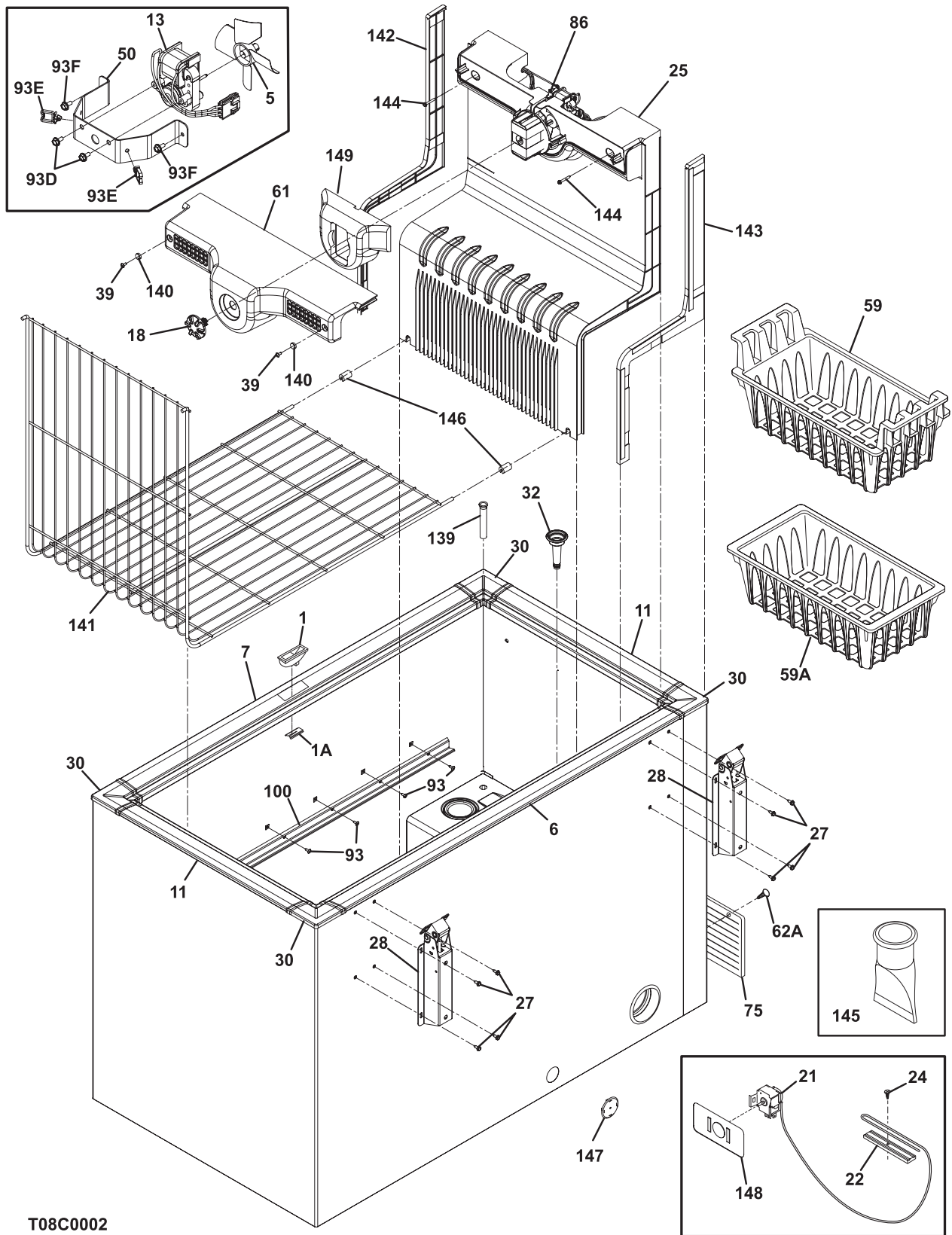

T08C0002

## CABINET

---

POS. NO	PART NO.	DESCRIPTION
1	216909800	Catch-lock, white
1A	216818900	Support, lock catch clip
5 #	216325600	Fan Blade
6	216111000	Breaker, Plain, white
7	216111600	Breaker, lock side
11	216110800	Breaker, chest end, (2)
13	216934100	Motor, fan, 115 V
18	216965300	Knob, cold control
21 #	216995600	Control, temperature, with sleeve
22	216823500	Clamp, cap tube, cold control
24	5300052943	Screw-clamp, truss hd cr, control
25	216966000	Cover, evaporator, manual
27	216629600	Screw, hex washer head, 10-16 x 0.500, tapping
28	216035200	Hinge
30	216110700	Breaker, corners
32	5308005500	Drain
39	5303293767	Screw, truss head, 8-18 x 0.625, front, (2), square drive
50	216964800	Bracket, fan motor mount
59	216916201	Basket, blue, upper, (2)
59A	216867401	Basket, blue, lower, (2)
61	216965600	Cover, airflow
62A	131420300	Screw, cr truss head, 8-18AB x 0.750
75	216034307	Panel-access, white
86	216036600	Screw, ph washer head, 8-32CA x 0.500, thread forming
93	5303161215	Screw, ph truss head, 8-18AB x 0.500
93D	216912400	Screw, hex washer head, #8-32 x .500, bracket fan mtr, (2)
93E	216327800	Clip, wire
93F	08016582	Screw, hi-lo blunt, 8-18 X 1/2, handle
100	216205103	Track-basket
139	216965800	Sleeve, suction line
140	216968300	Cover-screw
141	216968400	Trivet, floor vent
142	216989300	Spacer, left, with tape
143	216989400	Spacer, right, with tape
144	218362500	Screw, hex washer head, 8-18AB x 1.250, spacer, (2)
145	216968600	Drain, valve
146	216314500	Spacer, tube
147	216650200	Plug, foam
148	216964700	Bracket, cold control
149	216965700	Cover, molded, foam
*	216993200	Energy Guide
*	5303305324	Paint, touch-up, white

**SYSTEM**

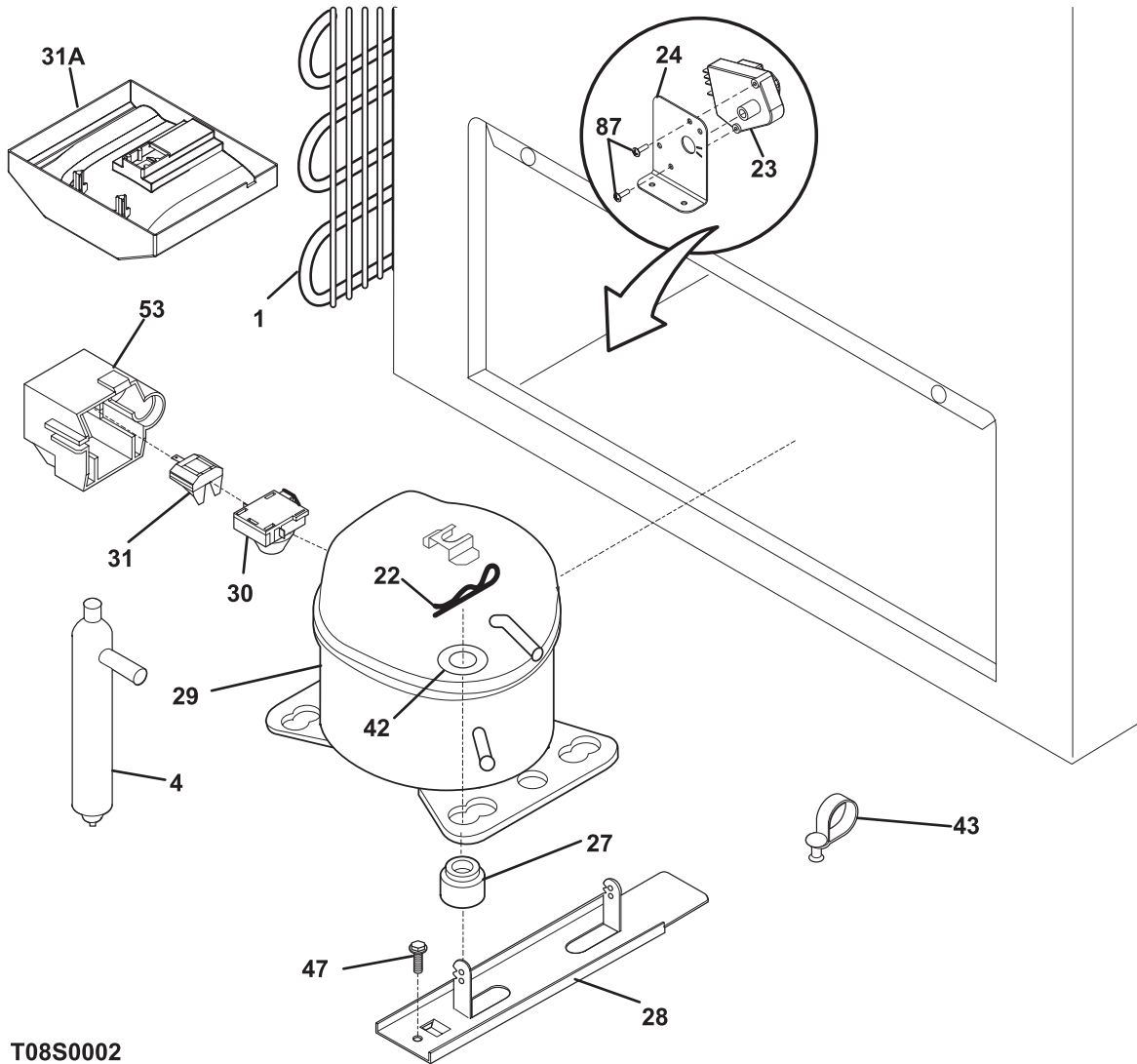
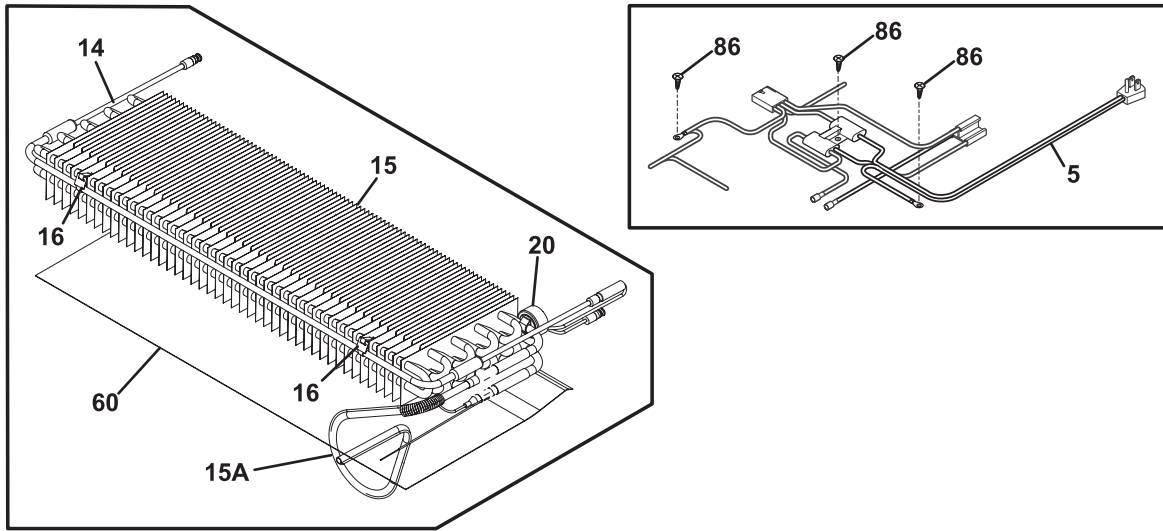

T08S0002

## SYSTEM

---

POS. NO	PART NO.	DESCRIPTION
1 #	5303925238	Condenser
4 #	216938600	Drier-filter
5 #	216955300	Harness-main
14 #	216967700	Heater-defrost
15 #	216965200	Evaporator, 2 pass
15A	216995700	Heat Exchanger
16	5308000110	Strap-evap/heater, aluminum, (2)
20	216731000	Thermostat, defrost
22	216056400	Clip, compressor mtg, SPRING
23 #	216744500	Timer-defrost
24	216968500	Bracket-timer
27	5308002681	Grommet, compressor
28	5303212615	Support, compressor
29	216966800	Compressor, assy
30	216596800	Starter, relay
31 #	216100106	Overload Protector
31A	216968800	Pan-drain, evaporator
42	216232700	Washer, flat, 1"OD x 0.531"ID
43	5303212614	Clip, harness mount
47	216629600	Screw, hex washer head, 10-16 x 0.500, tapping
53	216347800	Cover terminal, cover-comp term
60	216964900	Shield-heat
86	216036600	Screw, ph washer head, 8-32CA x 0.500, thread forming
87	08037849	Screw, ph truss head, 6-32(T) x 0.500, thread cutting