

## CFEF3054U S/W

### FREESTANDING RANGE

30" ELECTRIC



#### AVAILABLE COLOURS



#### PRODUCT DIMENSIONS

Height (Max.)	47"
Width	29-7/8"
Depth (Incl. Handle)	29-1/4"

#### MORE EASY-TO-USE FEATURES

**SpaceWise® Expandable Elements**  
Flexible elements expand to meet your cooking needs — big or small.

**Store-More™ Storage Drawer**  
With the Store-More™ Storage Drawer, you will have extra space to store your cookware.

**Large Capacity**  
Our large capacity oven gives you room to cook more dishes at once.

**Built with American Pride**  
Designed, engineered and assembled in the U.S.A.

**Colour-Coordinated Oven Door with Extra-Large Window**  
Our extra-large oven window makes it easier to check on the status of your dish without having to open the oven door.

**Timed Cook Option**  
Lets you set the oven to begin cooking at a predetermined time.

**Electronic Kitchen Timer**  
Times up to 12 hours.

### SIGNATURE FEATURES

#### One-Touch Self Clean

Your oven cleans itself — so you don't have to. Self clean options available in 2- and 3-hour cycles.

#### Quick Boil

Get meals on the table faster with our 3,000W element — water boils faster than the traditional setting.

#### Keep Warm Zone

Keep food warm until everything — and everyone — is ready.

#### Extra-Large Element

With our extra-large 12" element, you have more flexibility to fit larger pots and pans.

ELEMENTS	SIZE	WATTS
Right Front	12"	2,700
Right Rear	6"	1,200
Left Front	6"/9" Expandable	1,400/3,000
Left Rear	6"	1,200
Centre	Keep Warm Zone	100

# CFEF3054U S/W FREESTANDING RANGE

FRIGIDAIRE

30" ELECTRIC

## FEATURES

Oven Control/Timing System	Ready-Select® Controls
Surface Type	Black Ceramic Glass
Window	Extra-Large
Exterior Door Finish	Stainless (S), Colour-Coordinated (W)
Handle Design	Stainless (S), Colour-Coordinated (W)
Exterior Finish (Side Panels)	Black (S), Colour-Coordinated (W)
Oven Cleaning System	Self Clean
Drawer Functionality	Storage

## OVEN CONTROLS

Bake	Yes
Broil	Yes
Delay Start	Yes
Self-Clean	2, 3 Hour
Quick Clean Option	Yes
Delay Clean	Yes
Kitchen Timer	Yes
Timed Cook Option	Yes
Auto Oven Shut-Off	12 Hours
Oven Lock-Out	Yes

## COOKTOP FEATURES

Right Front Element (Watts)	12" - 2,700
Right Rear Element (Watts)	6" - 1,200
Left Front Element (Watts)	SpaceWise® Expandable 6"/9" - 1,400/3,000
Left Rear Element (Watts)	6" - 1,200
Centre Element (Watts)	Keep Warm Zone - 100
Hot Surface Indicator Light	Yes
Element "On" Indicator Light	Yes

## OVEN FEATURES

Capacity (Cu.Ft.)	5.3
Oven Light	1 Incandescent 40W
Rack Configuration	2 Standard
Baking System	Even Baking Technology
Broiling System	Vari-Broil™ (Hi/Lo)
Bake Element/Broil Element (Watts)	2,600/3,000

## SPECIFICATIONS

Oven Interior (H x W x D)	19-3/4" x 24-3/8" x 19-1/8"
Power Supply Connection Location	Middle Bottom Rear
Voltage Rating	240V/208V/60Hz
Connected Load (kW Rating) @ 240/208 Volts	11.5/8.5
Minimum Circuit Required (Amps)	40
Shipping Weight (Approx.)	185 Lbs.

## PRODUCT DIMENSIONS

A - Height (Max.)	47"
B - Width	29-7/8"
C - Depth (Incl. Handle)	29-1/4"
Depth with Door Open 90°	48-5/8"

## CABINET CUTOUT DIMENSIONS

Height (Standard)	36"
Width (Min.)	30"
Depth (Min.)	24"

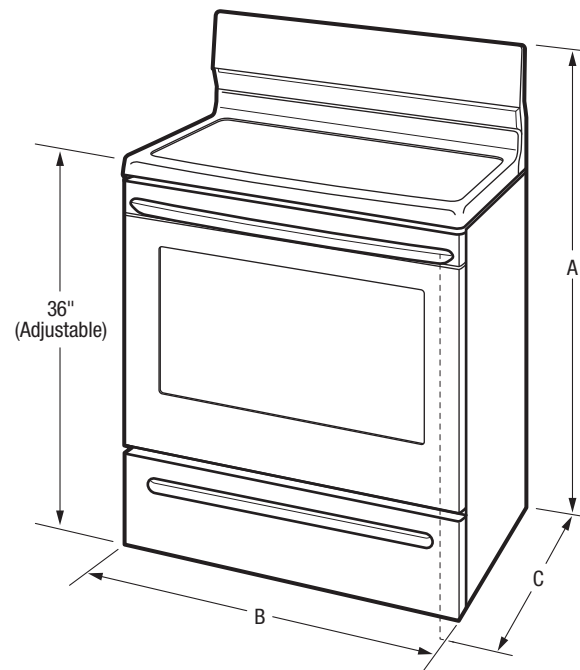

*Note: For planning purposes only. Always consult local and national electric, gas and plumbing codes. Refer to Product Installation Guide for detailed installation instructions on the web at [frigidaire.ca](http://frigidaire.ca). Specifications subject to change. Accessories information available on the web at [frigidaire.ca](http://frigidaire.ca)*

FRIGIDAIRE

CANADA • 5855 Terry Fox Way • Mississauga, ON L5V 3E4 • 1-800-265-8352 • [frigidaire.ca](http://frigidaire.ca)

CFEF3054U 07/18  
© 2018 Electrolux Major Appliances, NA

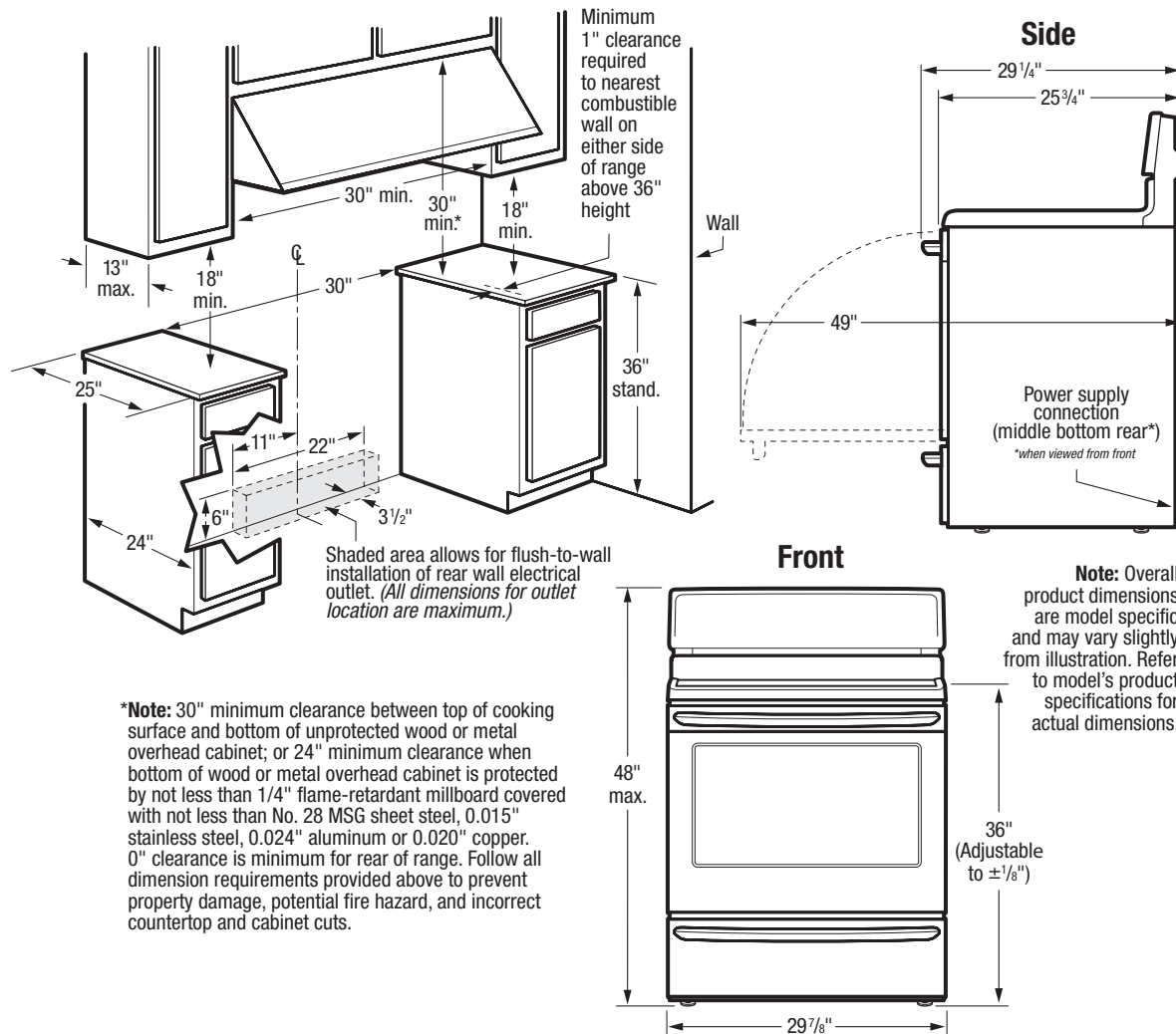

## INSTALLATION SPECIFICATIONS

- Product Shipping Weight (approx.) – 185 Lbs.
- Single phase 3- or 4-wire cable, 120/240 or 120/208 Volt, 60 Hertz, fused on both sides of line with ground.
- Connected Load (kW Rating) @ 240/208 Volts = 11.5/8.5kW
- Recommended Circuit Breaker – 40 Amps
- Always consult local and national electric codes.
- Make sure wall coverings around range can withstand heat generated by range.
- Floor beneath range MUST be solid and level.
- Overhead cabinetry should not exceed a 13" maximum depth.
- Absolute minimum horizontal distance between overhead cabinets installed to either side of appliance must be no less than maximum width of appliance.
- Range can be installed flush to wall with 0" minimum rear clearance.
- Minimum 1" clearance required from edge of rangetop to nearest combustible wall on either side of range above 36" height.
- Allow 30" minimum clearance between top of cooking surface and bottom of unprotected wood or metal overhead cabinet; or 24" minimum clearance when bottom of wood or metal overhead cabinet is protected by not less than 1/4" flame retardant millboard covered with not less than No. 28 MSG sheet steel, 0.015" stainless steel, 0.024" aluminum or 0.020" copper.
- To reduce risk of fire when using overhead cabinetry, install range hood that projects horizontally a recommended minimum of 5" beyond bottom of cabinets.
- Follow all dimension requirements provided to prevent property damage, potential fire hazard, and incorrect countertop and cabinet cuts.

