

30" ELECTRIC RANGE INSTALLATION INSTRUCTIONS

(For 3 or 4 Wire, 60 Hz. Systems)

INSTALLATION AND SERVICE MUST BE PERFORMED BY A QUALIFIED INSTALLER. IMPORTANT: SAVE FOR LOCAL ELECTRICAL INSPECTOR'S USE. READ AND SAVE THESE INSTRUCTIONS FOR FUTURE REFERENCE.

Clearances and Dimensions

1. Provide adequate clearances between the range and adjacent combustible surfaces.
2. Location—Check location where the range will be installed. Check for proper electrical supply, and the stability of the floor.
3. Dimensions that are shown must be used. Given dimensions provide minimum clearance. Contact surface must be solid and level.

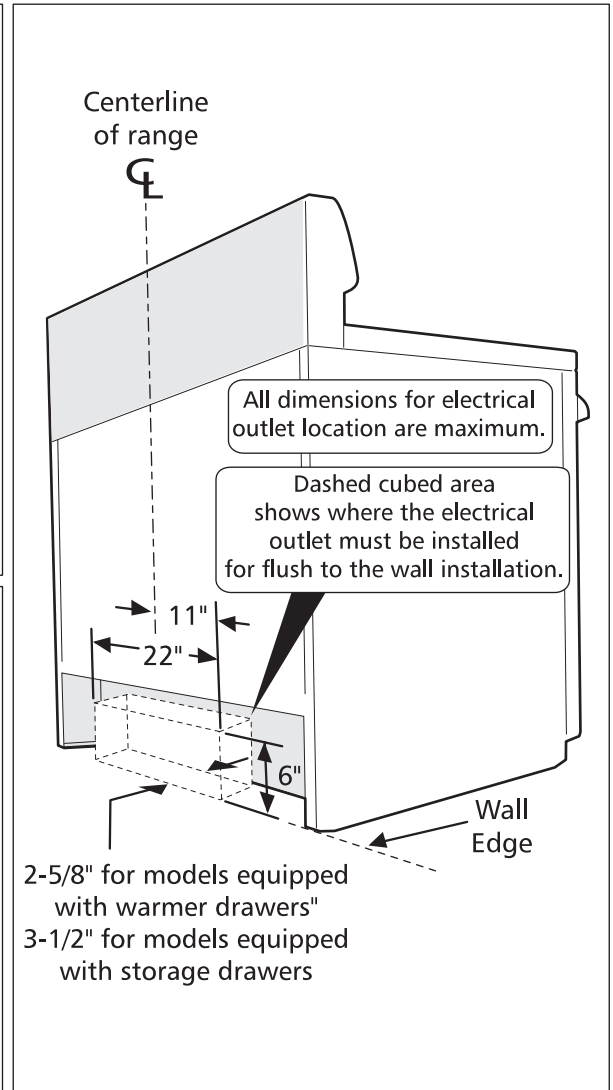
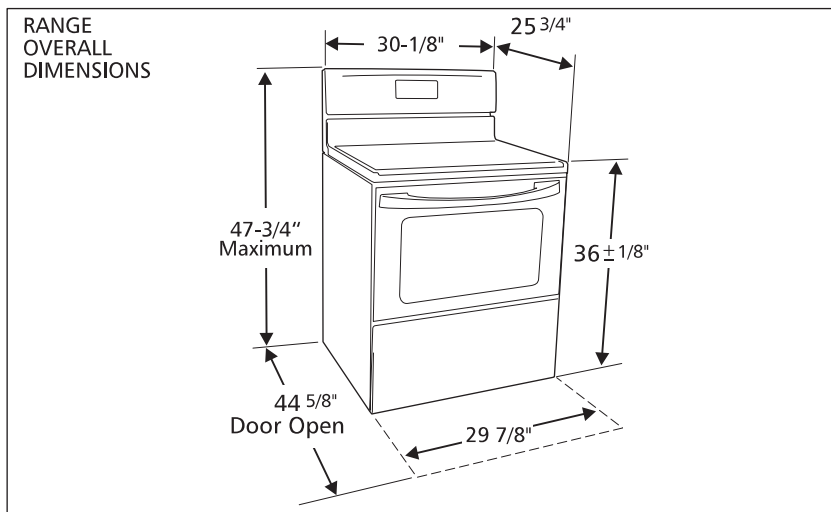
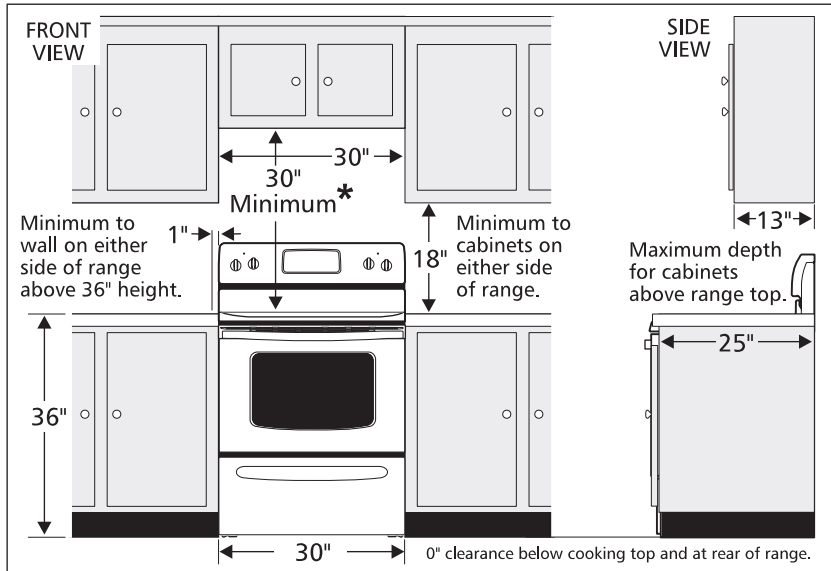

*30" MINIMUM CLEARANCE BETWEEN THE TOP OF THE COOKING SURFACE AND THE BOTTOM OF AN UNPROTECTED WOOD OR METAL CABINET; OR 24" MINIMUM WHEN BOTTOM OF WOOD OR METAL CABINET IS PROTECTED BY NOT LESS THAN 1/4" FLAME RETARDANT MILLBOARD COVERED WITH NOT LESS THAN NO. 28 MSG SHEET STEEL, 0.015" STAINLESS STEEL, 0.024" ALUMINUM OR 0.020" COPPER. 0" CLEARANCE IS THE MINIMUM FOR THE REAR OF THE RANGE. FOLLOW ALL DIMENSION REQUIREMENTS PROVIDED ABOVE TO PREVENT PROPERTY DAMAGE, POTENTIAL FIRE HAZARD, AND INCORRECT COUNTERTOP AND CABINET CUTS.

TO ELIMINATE THE RISK OF BURNS OR FIRE BY REACHING OVER HEATED SURFACE UNITS, CABINET STORAGE SPACE LOCATED ABOVE THE SURFACE UNITS SHOULD BE AVOIDED. IF CABINET STORAGE IS TO BE PROVIDED, THE RISK CAN BE REDUCED BY INSTALLING A RANGE HOOD THAT PROJECTS HORIZONTALLY A MINIMUM OF 5" BEYOND THE BOTTOM OF THE CABINETS.

30" ELECTRIC RANGE INSTALLATION INSTRUCTIONS

(For 3 or 4 Wire, 60 Hz. Systems)

IMPORTANT SAFETY INSTRUCTIONS

⚠ WARNING If the information in this manual is not followed exactly, a fire or electrical shock may result causing property damage, personal injury or death.



Important Notes to the Installer

1. Read all instructions contained in these installation instructions before installing range.
2. Remove all packing material from the oven compartments before connecting the gas and electrical supply to the range.
3. Observe all governing codes and ordinances.
4. Be sure to leave these instructions with the consumer.

Important Note to the Consumer

- Keep these instructions with your owner's guide for future reference.
- As when using any appliance generating heat, there are certain safety precautions you should follow. These are listed in the Use & Care Manual, read it carefully.
 - Be sure your range is installed and grounded properly by a qualified installer or service technician.
 - Make sure the wall coverings around the range can withstand the heat generated by the range.
 - To eliminate the need to reach over the surface elements, cabinet storage space above the elements should be avoided.

BEFORE STARTING

Tools You Will Need

For leveling legs and Anti-Tip Bracket:

- Adjustable wrench or channel lock pliers
- 5/16" Nutdriver or Flat Head Screwdriver
- Electric Drill & 1/8" Diameter Drill Bit (Masonry Drill Bit if installing in concrete)

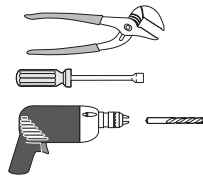

For electrical supply connection:

- 1/4" & 3/8" Socket driver or Nutdriver



Additional Materials You Will Need:

- Power Supply Cord or
- Copper Electrical Wiring & Metal Conduit (for hard wiring)



NORMAL INSTALLATION STEPS

1. Anti-Tip Bracket Installation Instructions - Important Safety Warning

To reduce the risk of tipping of the range, the range must be secured to the floor by properly installed anti-tip bracket and screws packed with the range. Failure to install the anti-tip bracket will allow the range to tip over if excessive weight is placed on an open door or if a child climbs upon it. Serious injury might result from spilled hot liquids or from the range itself.

If range is ever moved to a different location, the anti-tip brackets must also be moved and installed with the range.

Instructions are provided for installation in wood or cement fastened to either the floor or wall. When installed to the wall, make sure that screws completely penetrate dry wall and are secured in wood or metal. When fastening to the floor or wall, be sure that screws do not penetrate electrical wiring or plumbing.

A. Locate the Bracket Using the Template -

(Bracket may be located on either the left or right side of the range. Use the information below to locate the bracket if template is not available).

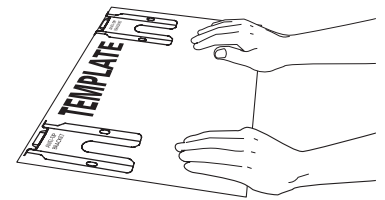

Mark the floor or wall where left or right side of the range will be located. If rear of range is against the wall or no further than 1-1/4" from wall when installed, you may use the wall or floor mount method. If molding is installed and does not allow the bracket to fit flush against the wall, remove molding or mount bracket to the floor. For wall mount, locate the bracket by placing the back edge of the template against the rear wall and the side edge of template on the mark made referencing the side of the range. Place bracket on top of template and mark location of the screw holes in wall. If rear of range is further than 1-1/4" from the wall when installed, attach bracket to the floor. For floor mount, locate the bracket by placing back edge of the template where the rear of the range will be located. Mark the location of the screw holes, shown in template.

B. Drill Pilot Holes and Fasten Bracket -

Drill a 1/8" pilot hole where screws are to be located. If bracket is to be mounted to the wall, drill pilot hole at an approximate 20° downward angle. If bracket is to be mounted to masonry or ceramic floors, drill a 5/32" pilot hole 1-3/4" deep. The screws provided may be used in wood or concrete material. Use a 5/16" nut-driver or flat head screwdriver to secure the bracket in place.

FASTEN BRACKET (WALL OR FLOOR MOUNTING)

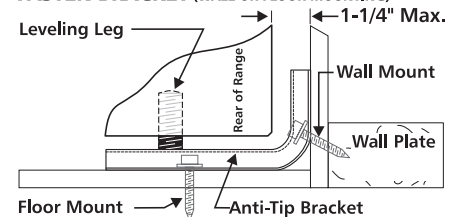

FASTEN BRACKET (FLOOR MOUNTING ONLY)

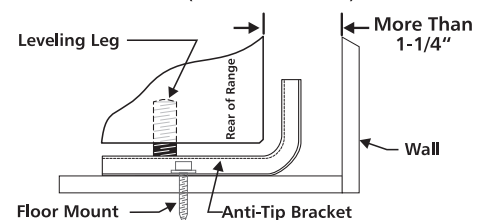

30" ELECTRIC RANGE INSTALLATION INSTRUCTIONS

(For 3 or 4 Wire, 60 Hz. Systems)

C. Level and Position Range -

Level range by adjusting the (4) leveling legs with a wrench. Note: A minimum clearance of 1/8" is required between the bottom of the range and the leveling leg to allow room for the bracket. Use a spirit level to check your adjustments. Slide range back into position.

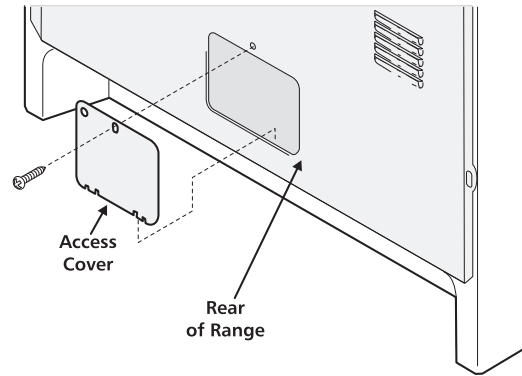
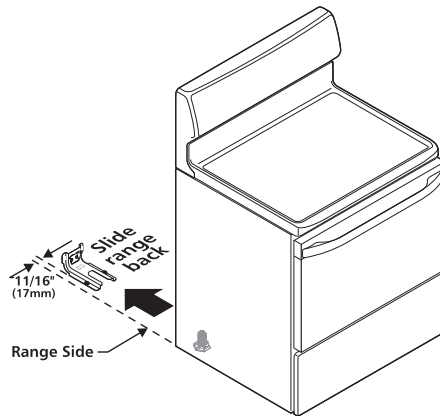

Visually check that rear leveling leg is inserted into and fully secured by the Anti-Tip Bracket by removing lower panel or storage drawer. For models with a warmer drawer or broiler compartment, grasp the top rear edge of the range and carefully attempt to tilt it forward.

2. Electrical Connection Requirements

This appliance must be properly installed and grounded by a qualified technician in accordance with the National Electrical Code ANSI/NFPA No. 70--latest edition--and local electrical code requirements.

This appliance may be connected by means of permanent "Hard Wiring" or "Power Supply Cord Kit."

When hard wiring, do not leave excess wire in range compartment. Excess wire in the range compartment may not allow the access cover to be replaced properly, and could create a potential electrical hazard if wires become pinched. Connect only as instructed under "WIRING INSTRUCTIONS" in section 4A or 4B. When using flexible conduit or range cable use flex connector or range cable strain relief.

NOTE: Only use copper wire in connection to terminal block.

2A. Models with Factory Connected Power Supply Cord

NOTE: Some models may be equipped with a factory connected three (3) conductor power supply cord.

Mobile home installations, new branch circuit installations (1996NEC) or areas where local codes do not permit grounding through neutral require a four (4) conductor power supply cord kit rated at 125/250 volts minimum and marked for use with ranges. See Range Connection Opening Size Chart for cord kit ampere rating information. Terminals on end of wires must be either closed loop or open-end spade lugs with upturned ends.

2B. Models Requiring Power Supply Cord Kit

RISK OF FIRE OR ELECTRICAL SHOCK MAY OCCUR IF AN INCORRECT SIZE RANGE CORD KIT IS USED, THE INSTALLATION INSTRUCTIONS ARE NOT FOLLOWED OR STRAIN RELIEF BRACKET IS DISCARDED.

This appliance may be connected by means of a power supply cord. Only a power supply cord kit rated at 125/250 volts minimum, and marked for use with ranges shall be used. See chart on page 3 for cord kit ampere rating information. Cord must have either three (3) or four (4) conductors. Terminals on end of wires must be either closed loop or open-end spade lugs with upturned ends. Cord must have strain relief clamp.

See section 4A for 3-wire or section 4B for 4-wire connection.

3. Electrical Connection to Range

The rear access cover must be removed. To remove, loosen center screw (one screw) and remove access cover. The terminal block will then be accessible.

Range Connection Opening Size Chart				
Supply Cord Kit ampere rating information. See serial plate on range for kilowatt rating data.				
See Serial Plate on Range for KW Rating	Cord Kit Ampere Rating	Diameter (inches) of Range connection Opening		
		Cord Kit	Permanent Wiring	
120/240 Volts 120/208 Volts				
8.8-16.5 KW 16.6-22.5 KW	7.9-12.5 KW 12.6-18.5 KW	40/50 Amp 50 Amp	1-3/8 in. 1-3/8 in.	1-1/8 in. 1-3/8 in.

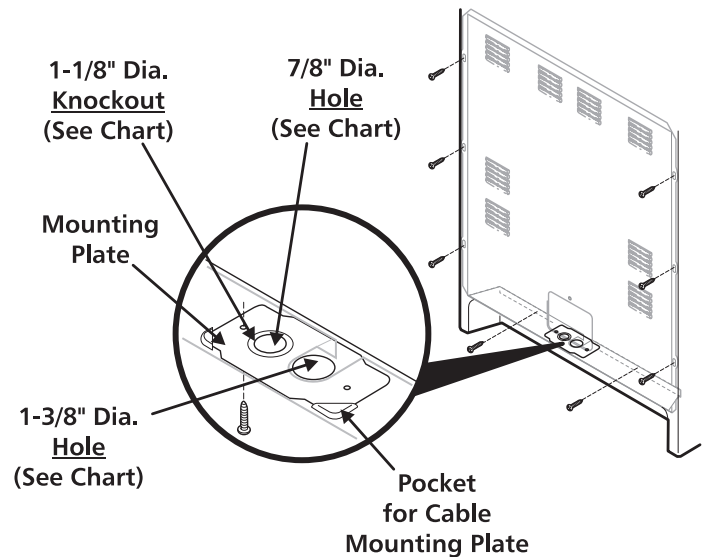

NOTE: Range is shipped from factory with 1-3/8" dia. hole as shown. To use either 7/8" dia. hole or 1-1/8" dia. knockouts:

If a different diameter hole is required, please follow the steps below:

1. Using a 1/4" socket driver, remove eight (8) screws from Rear Wall Shield to release from the unit (as shown). Save the screws for step #7 below.
2. Again using the 1/4" socket driver, remove one (1) blunt point screw used to secure the Cable Mounting Plate to the Rear Wall Shield. Save the screws for step #6.
3. Remove the Cable Mounting Plate from the Rear Wall Shield by sliding the plate out of the pockets.
4. If a 1-1/8" dia. hole is required, "punch-out" the knockout.
5. Rotate the plate 180 degrees so that the desired hole is placed on top of the opening located on the bottom flange of the Rear Wall Shield.
6. Slide the Cable Mounting Plate into the Rear Wall Shield. Re-secure using the blunt point screw removed from step #2 above.
7. Reassemble the Rear Wall Shield to the unit using eight (8) screws removed from step #1 above.

30" ELECTRIC RANGE INSTALLATION INSTRUCTIONS

(For 3 or 4 Wire, 60 Hz. Systems)

3-Wire Connection

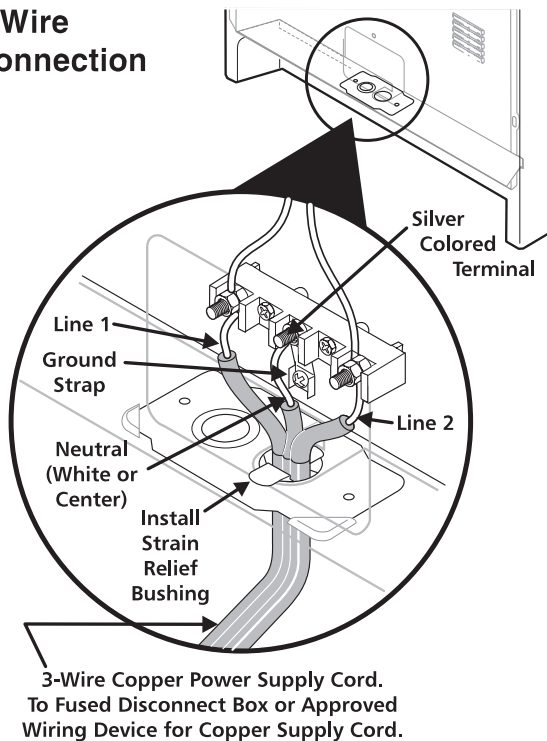

4-Wire Connection

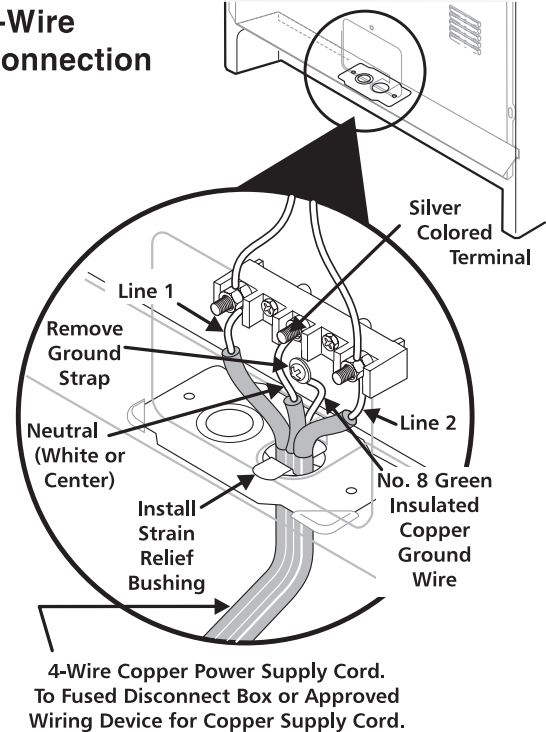

4A. Wiring Instructions (3-Wire Connection)

1. Remove the three (3) loose nuts on the terminal block using a 3/8" nut driver or socket.

NOTE: Do not loosen the nuts which secure the factory installed range wiring to the terminal block. Electrical failure or loss of electrical connection may occur if nuts are loosened.

2. Using the nuts removed in step 1, connect the cable or copper power supply cord to the three (3) studs on the terminal block, as local codes require. The neutral (white) wire or center wire must be connected to the center terminal.

3. Make sure all nuts are tightened securely.

4. Replace the rear access cover.

GROUNDING INSTRUCTIONS - A ground link is installed on this range which connects the center terminal of the terminal block (neutral) to the chassis. The ground link is not visible in the picture below but is connected to the range by the center, lowest screw (shown in picture ABOVE). The ground link must not be removed unless national or local codes do not permit use of ground link.

NOTE: If the ground link is removed for any reason, a separate ground wire must be connected to the separate ground screw attached to the range chassis and to an adequate ground source.

4B. Wiring Instructions (4-Wire Connection)

If connecting to a 4-wire electrical system (new branch-circuit or mobile home requires 4 wire connection):

1. Remove the three (3) loose nuts on the terminal block using a 3/8" nut driver or socket. From the center stud on the terminal block, remove the second nut and the copper ground strap. Replace the nut that held the ground strap to the terminal block. **NOTE:** Do not loosen the second nut on line 1 or line 2 which secure the factory installed range wiring to the terminal block. Electrical failure or loss of electrical connection may occur if nuts are loosened.

2. Remove the ground screw to release the copper ground strap from the appliance.

3. Discard the ground strap. Connect the ground wire (green) of the copper power supply cord to the frame of the appliance with the ground screw, using the same hole in the frame where the ground strap was removed.

4. Using the nuts removed in step 1, connect the neutral (white) wire of the copper power supply cord to the center silver colored stud on the terminal block.

5. Connect the final two (2) wires to the outer studs on the terminal block.

6. Make sure all nuts are tightened securely.

7. Replace the rear access cover.

Model and Serial Number Location

The serial plate location is provided in the Use & Care Manual. When ordering parts for or making inquiries about your range, always be sure to include the model and serial numbers and a lot number or letter from the serial plate on your range. Your serial plate also tells you the Kilowatt rating (power requirements) and Voltage ratings

Care, Cleaning and Maintenance

Refer to the Use & Care Manual for cleaning instructions. If removing the range is necessary for cleaning or maintenance, disconnect the electrical power supply. If the electrical supply is inaccessible, lift the unit slightly at the front and pull out away from the wall. Pull only as far as necessary to disconnect the electrical supply. Finish removing the unit for servicing and cleaning. Reinstall in reverse order making sure to level the range and check electrical connections. See pages 2 and 3 for proper anchoring instructions.

Before You Call for Service

Read the "Before You Call" and operating instruction sections in your Use & Care Manual. It may save you time and expense.

The list includes common occurrences that are not the result of defective workmanship or materials in this appliance.

Refer to the warranty in your Use & Care Manual for our toll-free service number and address. Please call or write if you have inquiries about your range product and/or need to order parts.