

SERVICE DATA SHEET

P/N: A05272301RevA
 Artwork: A05272301Rev001

FRIGIDAIRE
 Electronic Series

COLOR CODE

BK.....Black
 BU.....Blue
 PK.....Pink
 R.....Red
 Viol.....Violet
 W.....White
 Y.....Yellow
 R-Y.....Red/Yellow
 R-BK.....Red/Black

OPERATION

To start ----- **Close door fully to latch. Press START/PAUSE pad.**
 To delay start ----- **Close door fully to latch. Press DELAY TIME pad to select desired delay time.**
 To select a new cycle or option ----- **Press desired cycle and/or option pad. The indicator lights will change. Press START/PAUSE within 15 seconds to begin cycle.**
 To cancel a cycle ----- **Press CANCEL. Dishwasher will drain for 90 seconds, then shut off.**
 To Lock ----- **Press and hold the AIR DRY pad for 3 seconds. To unlock, press and hold the AIR DRY pad for 3 seconds.**

WARNING

Disconnect electrical power at the fuse box or circuit breaker box before servicing under this product. Electrical power may be present on some parts under this product, even if not in use.
 Failure to follow this warning could result in serious injury or death.

DISPLAY CODES (LED)

WASHING----- **Wash portion of cycle.**
 SANITIZED----- **The SANITIZED criteria has been met. Indicator light will switch off when door is opened for 15 seconds.**
 CLEAN----- **Shows completion of cycle. Indicator light will switch off when door is opened for 15 seconds.**

This information is intended for use by persons having electrical and mechanical training and a level of knowledge of these subjects generally considered acceptable in the appliance repair trade. Electrolux Home Products North America cannot be responsible, nor assume any liability, for injury or damage of any kind arising from the use of this Service Data Sheet.

WATER/SERVICE TEST

The water/service test, (WST) is a special function initiated from the power failure mode.

While in power failure mode - simultaneously press the AIR DRY and START/PAUSE pad.

The dishwasher will then step through the test cycle per the chart. Pushing the START/PAUSE pad will advance the dishwasher to the next step.

Interval Number	Fill Number	Description	Interval Duration (sec)	Water Valve	Circulation Motor	Drain Motor	Heater	Dispenser	Clean LED	Washing LED	Sanitize LED
1	1	Fill/Det. Dispenser	80	1	0	0	0	1	0	1	0
2	1	Wash/Heat	60	0	1	0	1	0	0	1	0
3	1	Pause/Heat	0.4	0	0	0	1	0	0	1	0
4	1	Wash/Heat	75	0	1	0	1	0	0	0	0
5	1	Pause	3	0	0	0	0	0	0	0	0
6	1	Wash/Heat/Det. Disp.	60	0	1	0	1	1	0	0	0
7	1	Drain	90	0	0	1	0	0	0	0	0
8	1	Dry Heater On/Drain	90	0	0	1	X	0	0	0	0
9	1	End State		0	0	0	0	0	1	0	1

*In step 8 when the AIR DRY pad is pressed this selects the heater on or off.

WIRING DIAGRAM

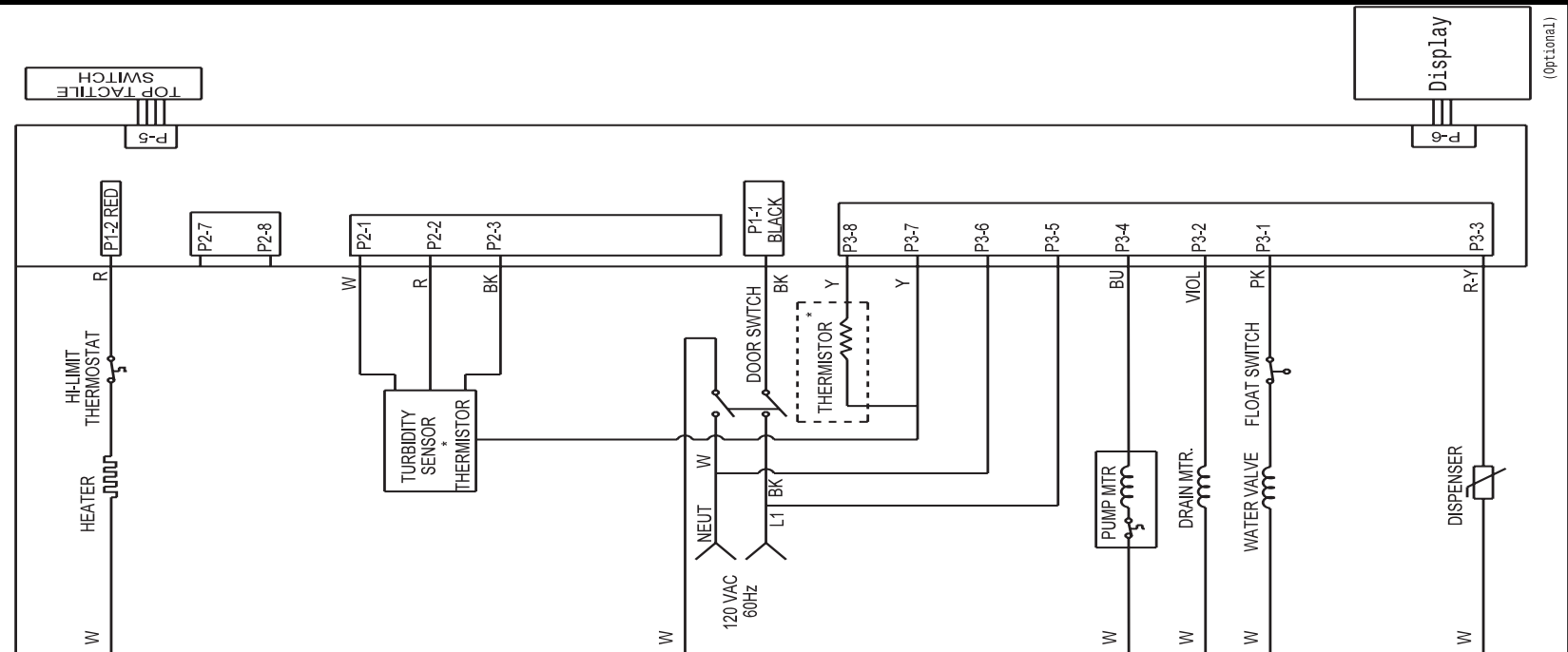

CYCLE SELECTION OPTIONS

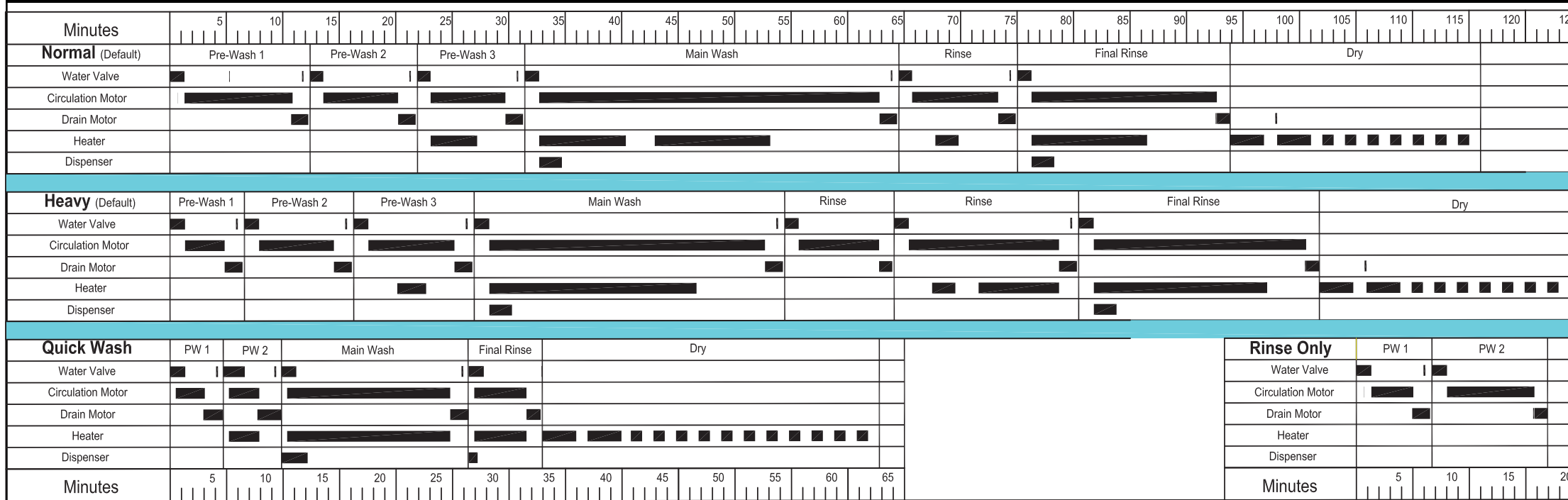

NOTE:

- In all cycles except Rinse Only and Quick Wash the main wash and final rinse may be lengthened when needed to reach optimal wash temperatures.
- If Normal Wash is the first cycle run after applying power the heavy soil response shown here will result. Thereafter, the sensor will be calibrated. Then, the cycle will automatically adjust to the amount of food soil by running only as many of the pre-washes or pre-rinse as appropriate.
- In the Quick Wash and Rinse Only cycles it is normal for the circulation pump to pulse during fills.

EXPLODED VIEW OF WASH SYSTEM

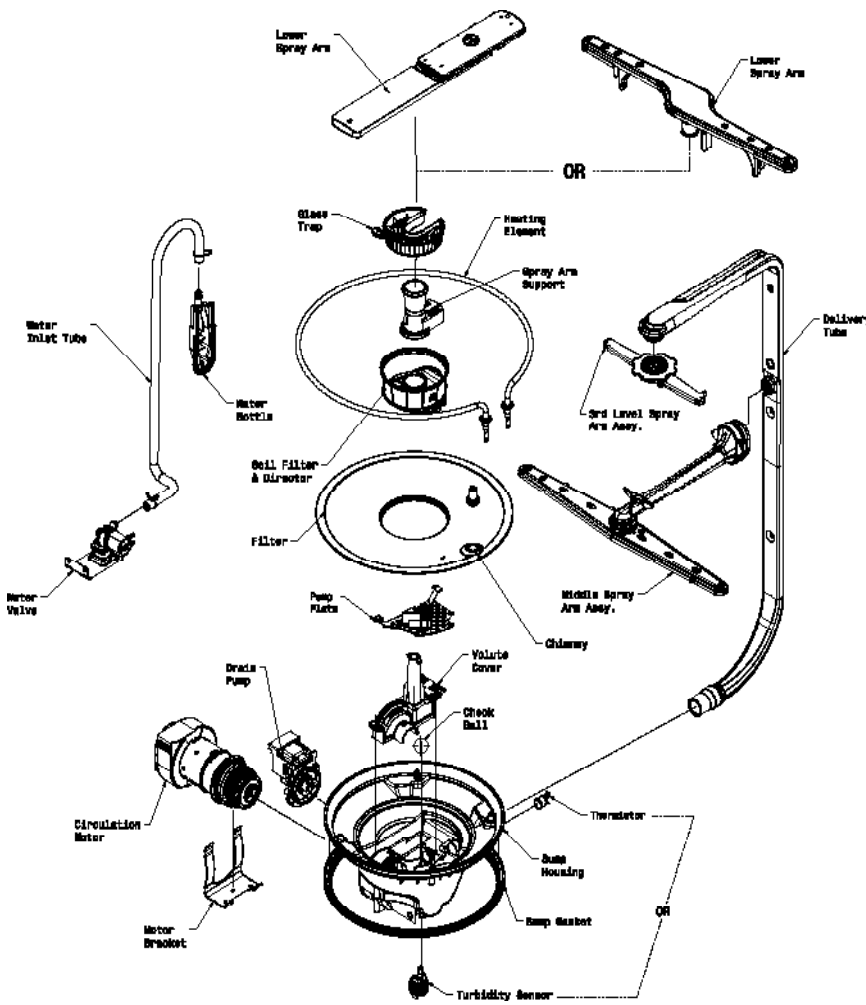

Pump Assembly

The assembly is driven by a synchronous motor. Rotation is in the counterclockwise direction at 2900RPM. The motor drives a pump which supplies 100 percent filtered water at a rate of approximately 12 GPM to one spray arm at a time. The spray arm's operation is alternated by small "pauses" of the motor during the wash cycle.

Draining is accomplished by using a small separate synchronous drain pump mounted to the side of the sump. The drain check valve is located at the discharge end of the drain pump. The drain hose is attached by a worm gear clamp to the discharge end of the drain pump.

900 Watt Heater

Refer to the cycle chart on the reverse side to determine when the heater is on during the wash cycle. The heater cycles **ON** and **OFF** for brief periods during the drying cycle.

The drain hose must have a loop at a **minimum height of 32 inches** in order to insure proper drainage.

To remove the main circulation (circ) pump do the following in sequence: Shut off electricity to the dishwasher. Disconnect the wiring harness connections located at the circ pump's motor. Remove the two screws that hold the motor bracket. Slide the motor bracket away from the sump. The motor and pump, now held only by friction against O-rings, can be pulled out of the sump.

Voltage checks of the heater should be made in the dry portion of the service test mode.

Standard Dry Air Flow

When the control advances to the "dry" portion of the cycle heated, moist air leaves the dishwasher through the console vent. Drier air is then drawn into the unit through vents at the bottom of the door. Heat stored in the dishware causes the water on the dishes to evaporate into the drier air.

This process continues throughout the drying phase as the heating element is turned **ON** and **OFF**.

Detergent and Rinse

The detergent and rinse aid dispenser is a one piece component consisting of a molded detergent cup and a built-in rinse aid dispenser.

The detergent cup has a spring loaded cover and the rinse aid dispenser has a removable cover.

To re-fill, remove the cap and pour rinse aid in until the level shows above the bottom of the cylindrical opening and the sight gauge changes appearance. If any is spilled wipe it up before starting the cycle. The amount of rinse aid released

can be adjusted by turning the arrow indicator from one, being the least amount, to four, being the greatest amount.

To replace dispenser:

- shut off electricity to dishwasher,
- remove outer door panel assembly,
- disconnect wiring to the actuator,
- remove the six screws,
- remove the dispenser,
- replace and reinstall screws,
- rewire actuator.

Tub and Door Seal

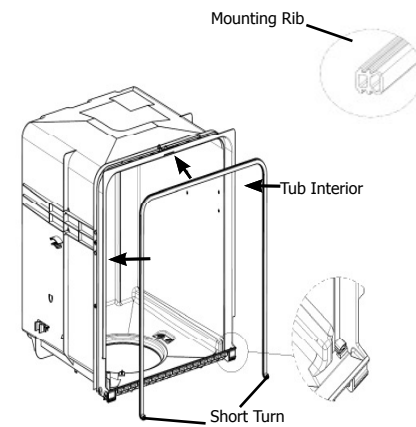

Line up the center mark on the back of the seal with the tub top center and press it into the channel. Move along the channel left and right periodically pressing the seal into place without bunching or stretching it until going around the corners at the top. Next, place the free ends into the channel at the bottom left and right by creating a short turn at the bottom of the tub channel and ensuring the seal extends to the locator ridge at the bottom of the tub (see enlarged portion of the attached image). Then, press the seal periodically into place. Finally slide your fingers over the seal to press it fully in place. When complete a single face of the seal should be visible and flush with the edge of the channel.

Product Specifications

Electrical

Rating.....	120 Volts, 60Hz
Separate Circuit..	15 amp min.....- 20 amp max.
Motor (Amps).....	1.8
Heater Wattage.....	900
Total Amps (load rated).....	10.0
TempAssure.....	140°F±5°F (60°C±3°C) [with outer door in place]
TempBoost.....	145°F±5°F (63°C±3°C) Heated Wash/Heated Rinse
Sanitize.....	150°F±5°F (66°C±3°C)
Hi-Limit Thermostat	200°F (93°C)

Water Supply

Suggested minimum incoming water temperature.....	120°F (49°C)
Pressure (PSI) min./max.....	20/120
Connection.....	3/8" NPT or 3/4" Hose Thread
Consumption (Normal Cycle).....	4.9 - 9.7 U.S. gal., 18.5 - 36.7
Water valve flow rate (U.S.GPM).....	83
Water recirculation (U.S. GPM).....	approx. 12
Water fill time.....	87

TROUBLE SHOOTING TIPS

⚠ WARNING

Personal Injury Hazard

Always disconnect the dishwasher from the electrical power source before adjusting or replacing components.

Symptom	Check the Following	Remedy
Dishwasher will not operate when turned on.	<ol style="list-style-type: none"> 1. Fuse (blown or tripped). 2. 120 VAC supply wiring connection faulty. 3. Electronic control board defective. 4. No 120 VAC power to control. 5. Motor (inoperative). 6. Door Switch (open contacts). 7. Door latch not making contact with door switch. 8. Touch pad circuit defective. 9. No indicator lamps illuminate when START or OPTIONS are pressed. 	<ol style="list-style-type: none"> 1. Replace fuse or reset breaker. 2. Repair or replace wire fasteners at dishwasher junction box. 3. Replace control board. 4. Replace control board. 5. Replace motor/impeller assembly. 6. Replace latch assembly. 7. Replace latch assembly. 8. Replace console assembly. 9. Replace console assembly.
Motor hums but will not start or run.	<ol style="list-style-type: none"> 1. Motor (bad bearings). 2. Motor stuck due to prolonged non-use. 	<ol style="list-style-type: none"> 1. Replace motor assembly. 2. Rotate motor impeller.
Motor trips out on internal thermal overload protector.	<ol style="list-style-type: none"> 1. Improper voltage. 2. Motor windings shorted. 3. Glass or foreign items in pump. 	<ol style="list-style-type: none"> 1. Check voltage. 2. Replace motor/impeller assembly. 3. Clean and clear blockage.
Dishwasher runs but will not heat.	<ol style="list-style-type: none"> 1. Heater element (open). 2. Electronic control board defective. 3. Wiring or terminal defective. 4. Hi-Limit thermostat defective. 5. Thermistor failure. 	<ol style="list-style-type: none"> 1. Replace heater element. 2. Replace control board. 3. Repair or replace. 4. Replace thermostat. 5. Replace turbidity sensor.
Detergent cover will not latch or open.	<ol style="list-style-type: none"> 1. Latch mechanism defective. 2. Electronic control board defective. 3. Wiring or terminal defective. 4. Broken spring (s). 5. Defective actuator. 	<ol style="list-style-type: none"> 1. Replace dispenser. 2. Replace control board. 3. Repair or replace. 4. Replace dispenser. 5. Replace dispenser.
Dishwasher will not pump out.	<ol style="list-style-type: none"> 1. Drain restricted. 2. Electronic control board defective. 3. Defective drain pump. 4. Blocked impeller. 5. Open windings. 6. Wiring or terminal defective. 	<ol style="list-style-type: none"> 1. Clear restrictions. 2. Replace control board. 3. Replace pump. 4. Check for blockage, clear. 5. Replace pump assembly. 6. Repair or replace.
Dishwasher will not fill with water.	<ol style="list-style-type: none"> 1. Water supply turned off. 2. Defective water inlet fill valve. 3. Check fill valve screen for obstructions. 4. Defective float switch. 5. Electronic control board defective. 6. Wiring or terminal defective. 7. Float stuck in "UP" position. 	<ol style="list-style-type: none"> 1. Turn water supply on. 2. Replace water inlet fill valve. 3. Disassemble and clean screen. 4. Repair or replace. 5. Replace control board. 6. Repair or replace. 7. Clean float.
Dishwasher water siphons out.	<ol style="list-style-type: none"> 1. Drain hose (high) loop too low. 2. Drain line connected to a 	<ol style="list-style-type: none"> 1. Repair to proper 32-inch minimum height. 2. Connect to a vented drain.
Detergent left in dispenser.	<ol style="list-style-type: none"> 1. Detergent allowed to stand too long in dispenser. 2. Dispenser wet when detergent was added. 3. Detergent cover held closed or blocked by large dishes. 4. Improper incoming water temperature to properly dissolve detergent. 5. See "Detergent cover will not open". 	<ol style="list-style-type: none"> 1. Instruct customer/user 2. Instruct customer/user 3. Instruct customer/user on proper loading of dishes. 4. Incoming water temperature of 120°F is required to properly dissolve dishwashing detergents.