

# Exploded View of Wash System

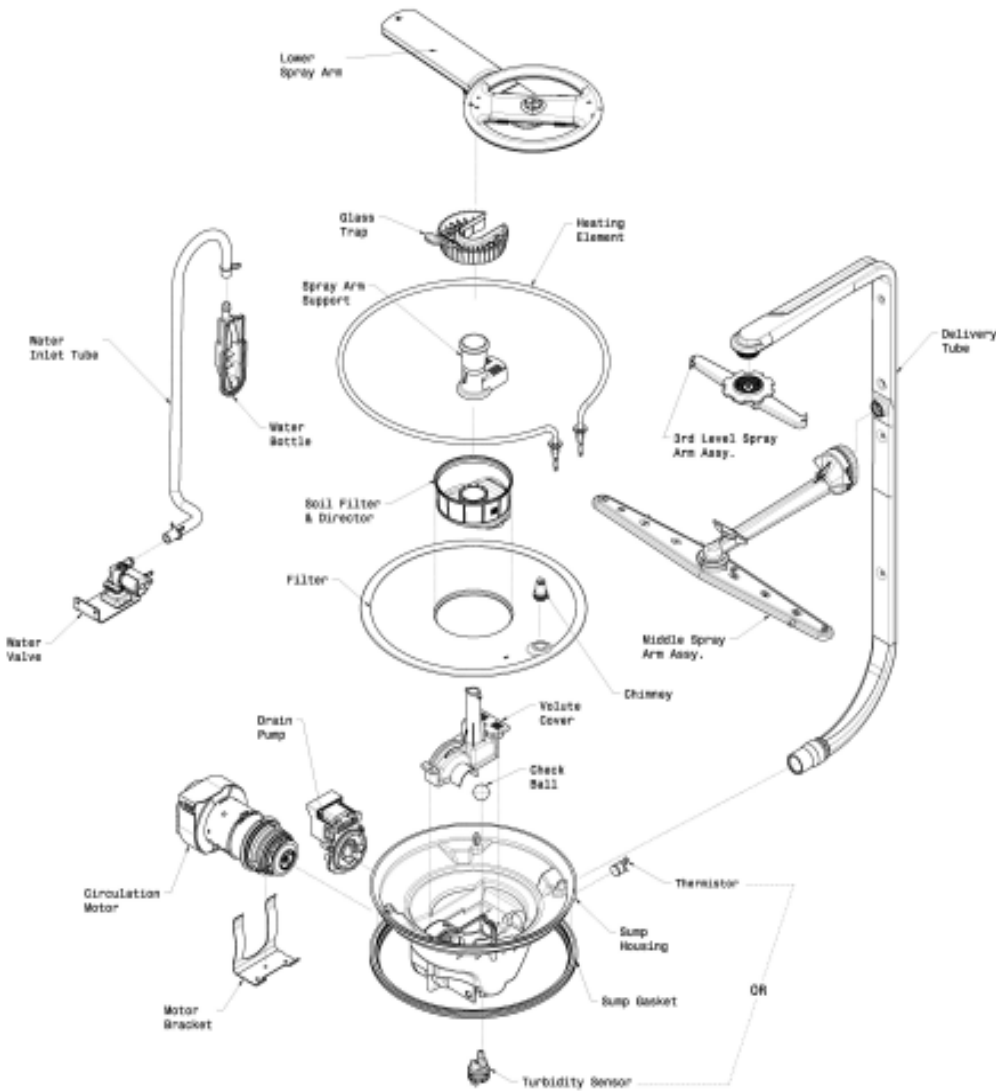

## Pump Assembly

The pump assembly is driven by a synchronous motor. Rotation is in the counterclockwise direction at 3600 RPM. The motor drives a pump which supplies 100 percent filtered water at a rate of approximately 12 GPM to one spray arm at a time. The spray arm's operation is alternated by small "pauses" of the motor during the wash cycle.

Draining is accomplished by using a small separate synchronous drain pump mounted to the side of the sump. The drain pump is connected to the main pump by a small rubber hose. The drain check valve is located at the discharge end of the drain pump. The drain hose

is attached by a worm gear clamp to the discharge end of the drain pump.

The drain hose must have a loop at a **minimum height of 32 inches** in order to insure proper drainage.

The main pump can easily be removed by disconnecting the upper spray arm supply tube hose, the drain pump connector hose, the wiring harness connections made at the circulation motor, the water heat thermistor located on the bottom of the pump and rotating the four sump retainers toward the middle of the sump.

## Standard Dry Air Flow

When the control advances to the "dry" portion of the cycle, a vent actuation solenoid is closed. This opens the vent valve and starts the vent fan both located in the top right rear corner of the tub. The fan draws in the air from outside the tub, forcing the hot, humid air down and out the

bottom of the outer door panel. This outside, cooler, dryer air helps to speed evaporation of water from the hot dishes. At the same time the heating element is continually cycled on and off. On some models the dry portion of the cycle can be extended to improve drying performance.

## Detergent and Rinse Aid Dispenser

The detergent and rinse aid dispenser is a one piece component consisting of a molded detergent cup and a built-in rinse aid dispenser.

The detergent cup has a spring loaded cover and the rinse aid dispenser has a removable cover.

Liquid rinse aid is added to the dispenser up to the fill line indicator. The amount of rinse aid released can be adjusted by turning the arrow indicator from one, being the least amount, to four, being the greatest amount.

### To replace dispenser:

- shut off electricity to dishwasher,
- remove outer door panel assembly,
- disconnect wiring to the actuator,
- remove the six screws,
- remove the dispenser,
- replace and reinstall screws,
- rewire actuator.

## Tub and Door Seal

The door seal is pressed into the tub channel for an interference fit. To install the seal, locate the center mark on the seal back and press into place. Next, install the bottom of the seal by creating a short turn at the bottom of the tub channel and ensuring the seal extends to the

locator ridge at the bottom of the tub. Then align and gently press the seal into the channel in only a few spots. Next, close and latch the door to allow the gasket to seat properly into the channel.

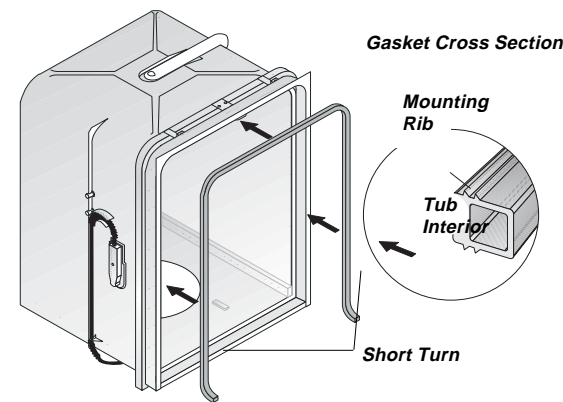

## Product Specifications

### Electrical

Rating .....	120 Volts, 60Hz
Separate Circuit..15 amp min.- 20 amp max.	
Motor (Amps) .....	1.8
Heater Wattage .....	900
Total Amps (load rated) .....	10.0
TempAssure .....	140°F ±5°F (60°C±3°C) [with outer door in place]
TempBoost.....	145°F ±5°F (63°C ±3°C)
	Heated Wash/Heated Rinse
Sanitize .....	150°F ±5°F (66°C ±3°C)
Hi-Limit Thermostat .....	200°F (93°C)

### Water Supply

Suggested minimum incoming water temperature .....	120°F (49°C)
Pressure (PSI) min./max. ....	20/120
Connection (NPT) .....	3/8"
Consumption (Normal Cycle) .....	4.9 - 9.7 U.S. gal., 18.5 - 36.7 liters
Water valve flow rate (U.S. GPM) .....	.83
Water recirculation rate (U.S. GPM) .....	approx. 12
Water fill time .....	87 sec.

# Trouble Shooting Tips

## ⚠ WARNING

### Personal Injury Hazard

Always disconnect the dishwasher from the electrical power source before adjusting or replacing components.

Symptom	Check the Following	Remedy
Dishwasher will not operate when turned on.	<ol style="list-style-type: none"> <li>1. Fuse (blown or tripped).</li> <li>2. 120 VAC supply wiring connection faulty.</li> <li>3. Electronic control board defective.</li> <li>4. No 12 VAC power to control.</li> <li>5. Motor (inoperative).</li> <li>6. Door switch (open contacts).</li> <li>7. Door latch not making contact with door switch.</li> <li>8. Touch pad circuit defective.</li> <li>9. No indicator lamps illuminate when START or OPTIONS are pressed.</li> </ol>	<ol style="list-style-type: none"> <li>1. Replace fuse or reset breaker.</li> <li>2. Repair or replace wire fasteners at dishwasher junction box.</li> <li>3. Replace control board.</li> <li>4. Replace control board.</li> <li>5. Replace motor/impeller assembly.</li> <li>6. Replace latch assembly.</li> <li>7. Replace latch assembly.</li> <li>8. Replace console assembly.</li> <li>9. Replace console assembly.</li> </ol>
Motor hums but will not start or run.	<ol style="list-style-type: none"> <li>1. Motor (bad bearings).</li> <li>2. Motor stuck due to prolonged non-use.</li> </ol>	<ol style="list-style-type: none"> <li>1. Replace motor assembly.</li> <li>2. Rotate motor impeller.</li> </ol>
Motor trips out on internal thermal overload protector.	<ol style="list-style-type: none"> <li>1. Improper voltage.</li> <li>2. Motor windings shorted.</li> <li>3. Glass or foreign items in pump.</li> </ol>	<ol style="list-style-type: none"> <li>1. Check voltage.</li> <li>2. Replace motor/impeller assembly.</li> <li>3. Clean and clear blockage.</li> </ol>
Dishwasher runs but will not heat.	<ol style="list-style-type: none"> <li>1. Heater element (open).</li> <li>2. Electronic control board defective.</li> <li>3. Wiring or terminal defective.</li> <li>4. Hi-Limit thermostat defective.</li> </ol>	<ol style="list-style-type: none"> <li>1. Replace heater element.</li> <li>2. Replace control board.</li> <li>3. Repair or replace.</li> <li>4. Replace thermostat.</li> </ol>
Detergent cover will not latch or open.	<ol style="list-style-type: none"> <li>1. Latch mechanism defective.</li> <li>2. Electronic control board defective.</li> <li>3. Wiring or terminal defective.</li> <li>4. Broken spring(s).</li> <li>5. Defective actuator.</li> </ol>	<ol style="list-style-type: none"> <li>1. Replace dispenser.</li> <li>2. Replace control board.</li> <li>3. Repair or replace.</li> <li>4. Replace dispenser.</li> <li>5. Replace dispenser.</li> </ol>
Dishwasher will not pump out.	<ol style="list-style-type: none"> <li>1. Drain restricted.</li> <li>2. Electronic control board defective.</li> <li>3. Defective drain pump.</li> <li>4. Blocked impeller.</li> <li>5. Open windings.</li> <li>6. Wiring or terminal defective.</li> </ol>	<ol style="list-style-type: none"> <li>1. Clear restrictions.</li> <li>2. Replace control board.</li> <li>3. Replace pump.</li> <li>4. Check for blockage, clear.</li> <li>5. Replace pump assembly.</li> <li>6. Repair or replace.</li> </ol>
Dishwasher will not fill with water.	<ol style="list-style-type: none"> <li>1. Water supply turned off.</li> <li>2. Defective water inlet fill valve.</li> <li>3. Check fill valve screen for obstructions.</li> <li>4. Defective float switch.</li> <li>5. Electronic control board defective.</li> <li>6. Wiring or terminal defective.</li> <li>7. Float stuck in "UP" position.</li> </ol>	<ol style="list-style-type: none"> <li>1. Turn water supply on.</li> <li>2. Replace water inlet fill valve.</li> <li>3. Disassemble and clean screen.</li> <li>4. Repair or replace.</li> <li>5. Replace control board.</li> <li>6. Repair or replace.</li> <li>7. Clean float.</li> </ol>
Dishwasher water siphons out.	<ol style="list-style-type: none"> <li>1. Drain hose (high) loop too low.</li> <li>2. Drain line connected to a floor drain not vented.</li> </ol>	<ol style="list-style-type: none"> <li>1. Repair to proper <b>32-inch minimum height</b>.</li> <li>2. Install air gap at counter top.</li> </ol>
Detergent left in dispenser.	<ol style="list-style-type: none"> <li>1. Detergent allowed to stand too long in dispenser.</li> <li>2. Dispenser wet when detergent was added.</li> <li>3. Detergent cover held closed or blocked by large dishes.</li> <li>4. Improper incoming water temperature to properly dissolve detergent.</li> <li>5. See "Detergent cover will not open."</li> </ol>	<ol style="list-style-type: none"> <li>1. Instruct customer/user.</li> <li>2. Instruct customer/user.</li> <li>3. Instruct customer/user on proper loading of dishes.</li> <li>4. Incoming water temperature of 120°F is required to properly dissolve dishwashing detergents.</li> </ol>

**P/N: 154889701**

# FRIGIDAIRE

## Electronic Series

This information is intended for use by persons having electrical and mechanical training and a level of knowledge of these subjects generally considered acceptable in the appliance repair trade. Electrolux Home Products, North America cannot be responsible, nor assume any liability, for injury or damage of any kind arising from the use of this Service Data Sheet.

### Color Code

BK.....	Black
BU.....	Blue
PK.....	Pink
R.....	Red
R-BK.....	Red/BK
W.....	White
Y-BK..	Yellow/BK

### Operation

**To start.....** Close and latch door. Press START/CANCEL pad.

**To delay start..** Close and latch door. Press DELAY START pad to select desired delay time.

**To select a new cycle or option-** Press desired cycle and/or option pad. The indicator lights will change. Press START/CANCEL within 15 seconds to begin cycle.

**To cancel cycle** Press START/CANCEL. Dishwasher will drain for 90 seconds, then shut off.

**For controls lock .....** Press and hold the RINSE ONLY or AIR DRY pad for 3 seconds.  
To unlock, press and hold the RINSE ONLY or AIR DRY pad for 3 seconds.

### Display Codes (Readout)

**PF.....**A power failure has occurred

**Hd or HO.....**Water heating delay

**CL.....**Close and latch the door

**ER/ER.....**Switch Failure

**ER/CE.....**Configuration Error

**ER/uo.....**Vent will not close

**ER/uF.....**Fan not running

**'01-24'.....**Hour(s) delay before Start (some models)

### Display Codes (LED)

**SENSING .....** Turbidity sensor is checking the condition of the wash/rinse water. No sensing for LIGHT WASH (UPPER RACK), LIGHT WASH (LOWER RACK) and CHINA/CRYSTAL.

**WASHING .....** Wash portion of cycle.

**SANITIZED .....** The SANITIZED criteria has been met. Indicator light will switch off when door is opened.

**DRYING .....** Drying portion of cycle.

**CLEAN .....** Shows completion of cycle. Indicator light will switch off when door is opened.

**OPTION LED's Flashing --** HI-TEMP WASH and NO HEAT DRY/POWER DRY OFF LED's flashing indicates power failure has occurred. Press START/CANCEL pad and

### Water/Service Test

To activate Water/Service Test place unit in Power Failure or Idle Mode and the press "DRY or "AIR DRY"(model dependent) and the START/CANCEL keys for 3 seconds.

The dishwasher will then step through the test cycle per the chart, if at any time, the START/CANCEL key is pressed, the current step is terminated, while the test sequence advances to The next cycle step.

STEP	TOTAL TIME (SEC)	WATER VALVE	CIRCULATION MOTOR	DRAIN MOTOR	HEATER	DISPENSER	FAN UNIT	WASHING LED	SANITIZED LED	DRYING LED	CLEAN LED	SENSING LED	RINSE LED	Device being monitored	Display flashes when Detection of failure
1	FILL/DISPENSER	60	1	0	0	0	1	0	0	0	0	1	0	Fan Damper	Uo
2	FILL	27	1	0	0	0	0	1	0	0	0	1	0	Turbidity	Tu
3	WASH/HEAT/DISP.	45	0	1	0	1	1	0	1	0	0	0	1	Hall Sensor	HS
4	PAUSE	0.4	0	0	0	1	0	0	1	0	0	0	1		
5	WASH/HEAT	75	0	1	0	1	0	0	0	0	0	0	1		
6	WASH/HEAT/DISP.	60	0	1	0	1	1	0	0	0	0	0	1	Thermistor	Th
7	DRAIN	90	0	0	1	0	0	1	0	0	0	0	0	Fan Speed	UF
8	DRY	90	0	0	1	X	0	1	0	0	1	0	0	Rinse Aid	RA
TOTAL		447							0	1	0	1	0		

X - denotes selectable option

CLEAN LED stays on until door is opened or cycle is started.

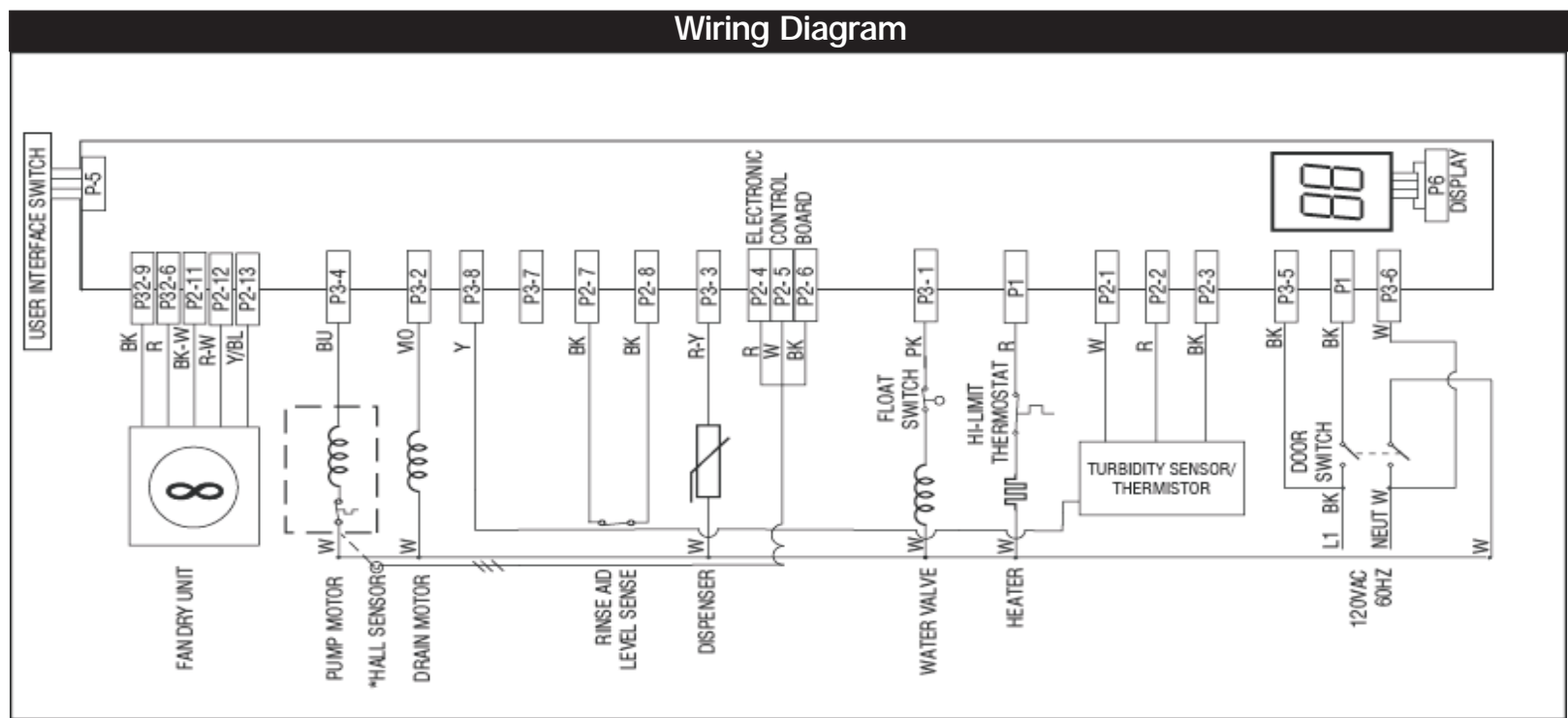

### Cycle Selection Options

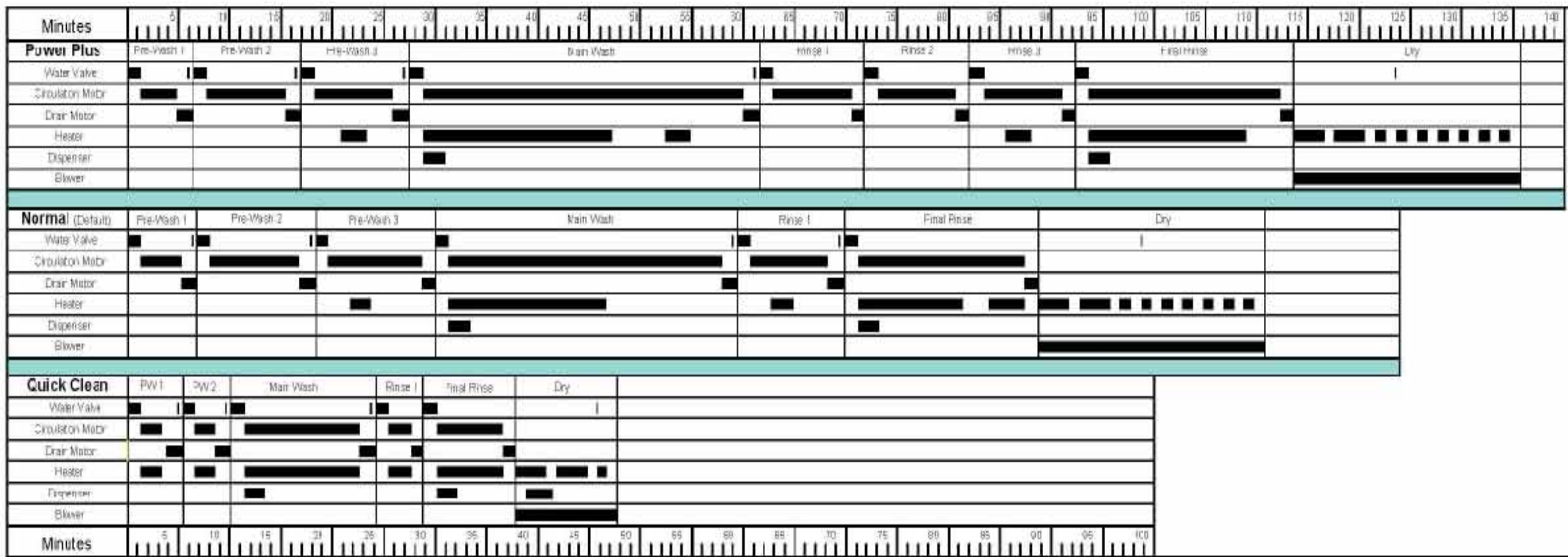

Note: The Main Wash and Final Rinse may be lengthened when needed to reach optimal wash temperatures. The heavy response option for Power Plus and for Normal is depicted. This response will result from a first run after applying power or when heavy soils are put in the dishwasher. If lighter soil loads are input each of these cycles would be automatically shortened by eliminating as many pre-washes or pre-rinse as is appropriate.

