

# CAUTION: DISCONNECT ELECTRIC CURRENT BEFORE SERVICING

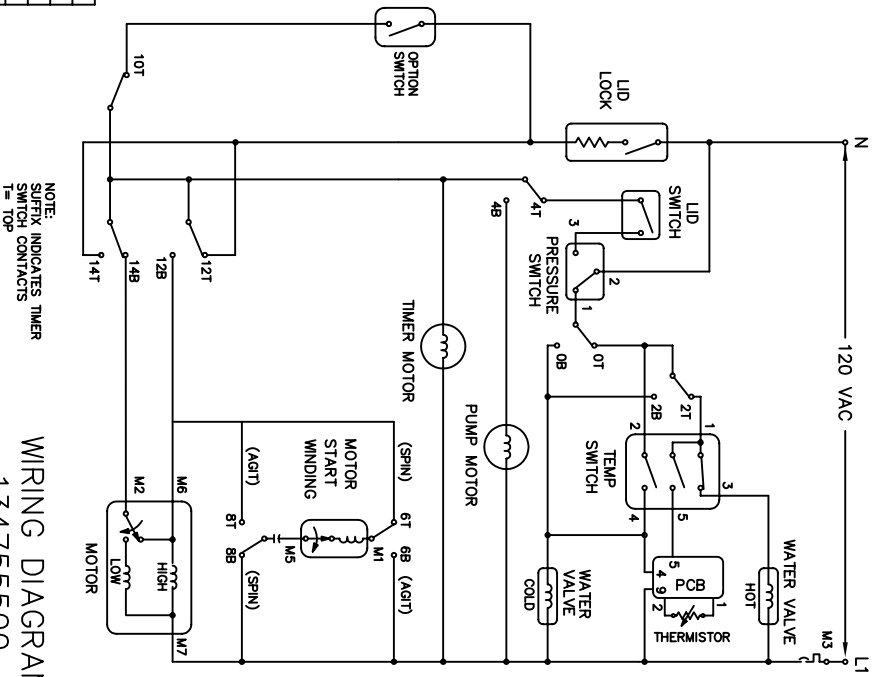
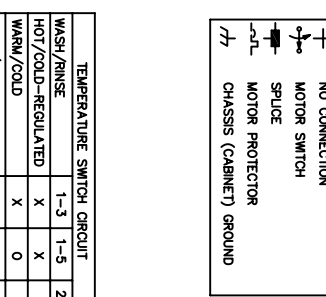
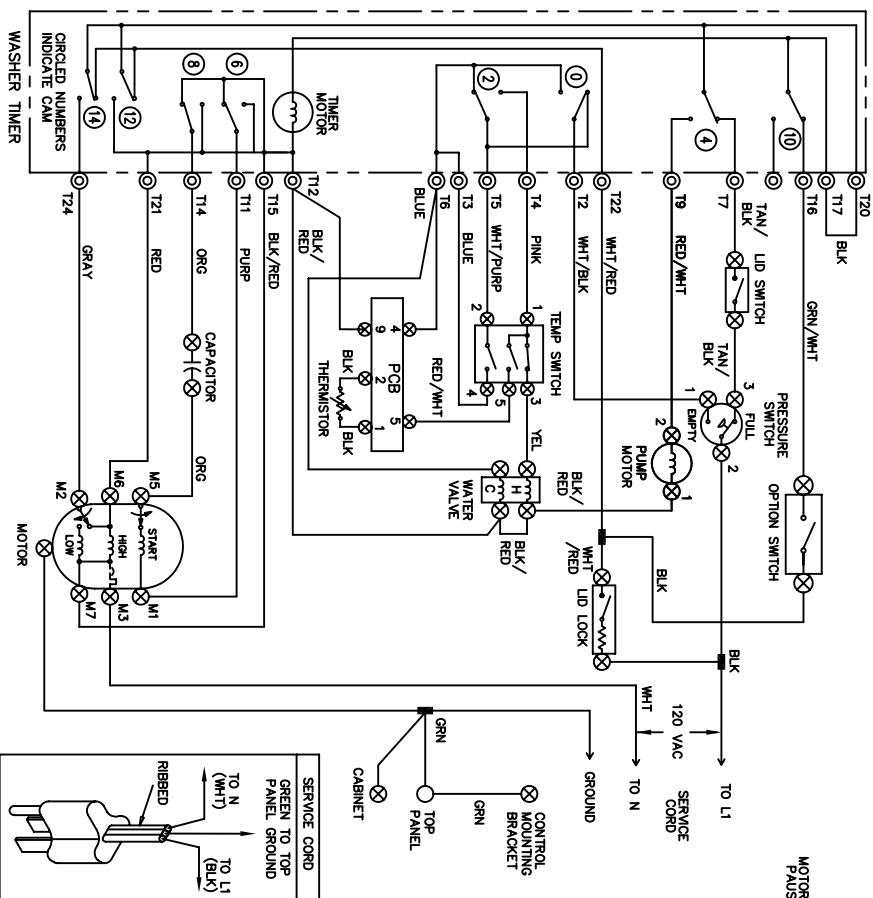
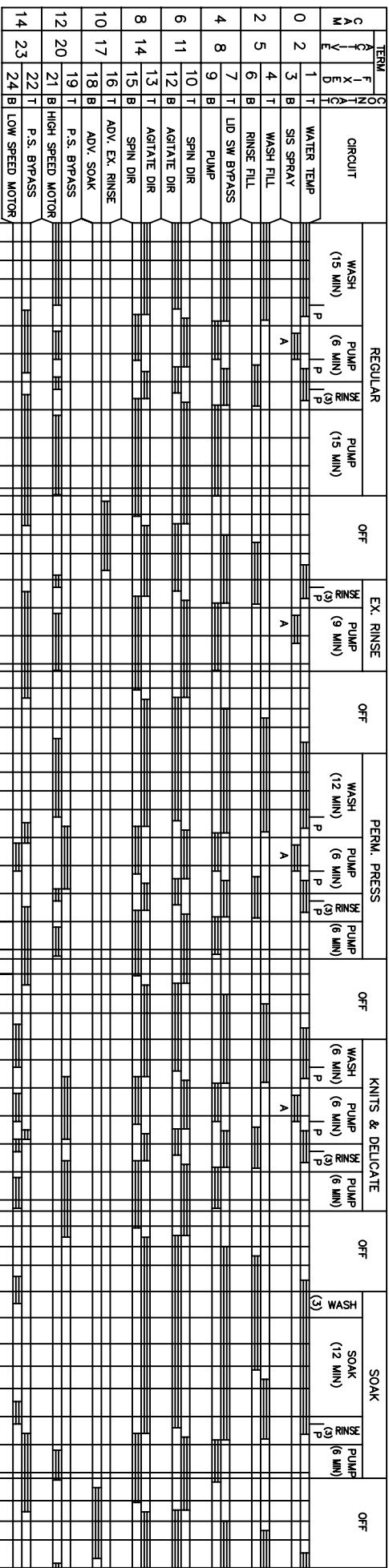

- WINNING CODES**
- ⊙ PLUG IN TIMER TERMINAL
  - ⊗ QUICK DISCONNECT TERMINAL
  - SCREW TERMINAL
  - ⊕ CONNECTION
  - ⊖ NO CONNECTION
  - ⊚ MOTOR SWITCH
  - ⊛ SPURGE
  - ⊜ MOTOR PROTECTOR
  - ⊝ CHASSIS (CABINET) GROUND

**TEMPERATURE SWITCH CIRCUIT**

	1-3	1-5	2-4
WASH/RINSE	X	X	0
HOT/COLD-REGULATED	X	X	0
WARM/COLD	0	0	X
COLD/COLD	0	0	X

0=OPEN X=CLOSED

NOTE: SUFFIX INDICATES TIMER SWITCH CONTACTS  
 T= TOP  
 B= BOTTOM

WIRING DIAGRAM  
 134755500 A

# MISE EN GARDE: METTRE HORS TENSION AVANT D'EFFECTUER

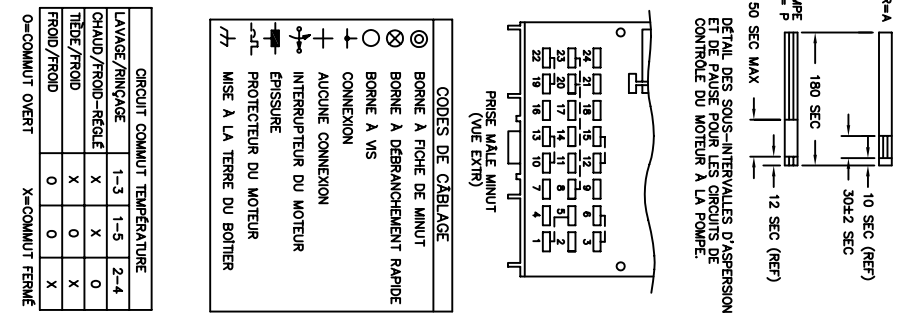
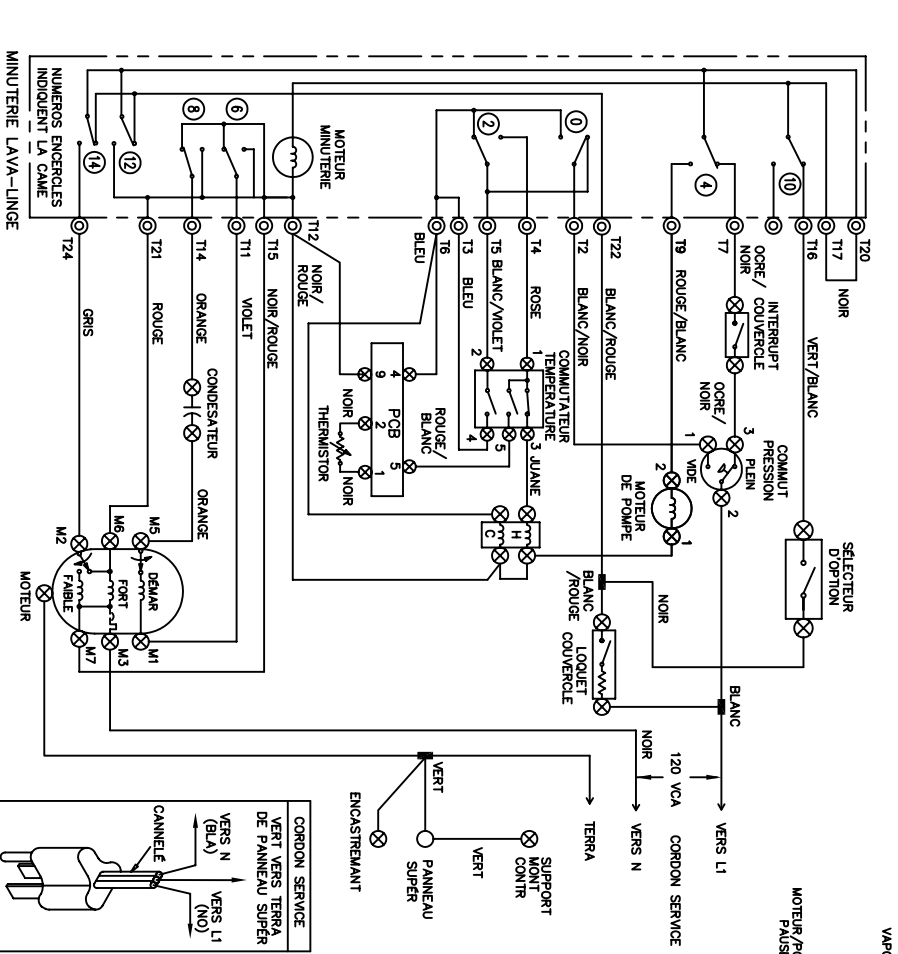
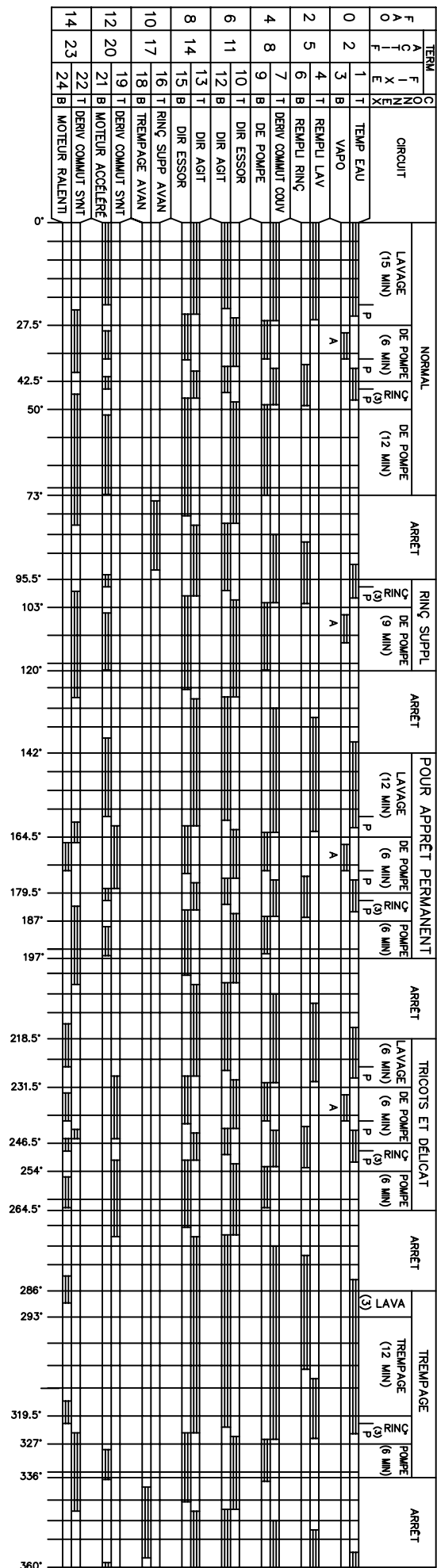

- CODES DE CÂBLAGE**
- ⊙ BORNE A FICHE DE MINUT
  - ⊗ BORNE A DEBRANCHEMENT RAPIDE
  - BORNE A VIS
  - CONNEXION
  - + AUCUNE CONNEXION
  - ⊕ INTERRUPTEUR DU MOTEUR
  - ⊖ EPISURE
  - ⊖ PROTECTEUR DU MOTEUR
  - ⊖ MISE A LA TERRE DU BOITIER

CIRCUIT COMMUT TEMPERATURE	1-3	1-5	2-4
LAVAGE/RINGAGE	X	X	0
CHAUD/FROID-REGLE	X	X	0
TIEDE/FROID	X	0	X
FROID/FROID	0	0	X

0-COMMUT OVERT X-COMMUT FERME

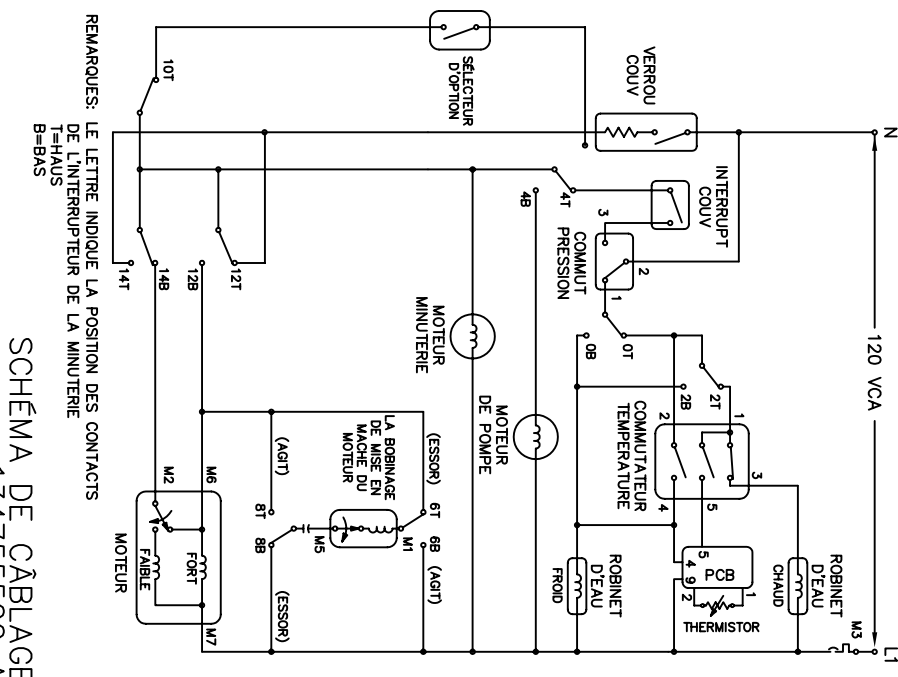

REMARQUES: LE LETTRE INDIQUE LA POSITION DES CONTACTS DE L'INTERRUPTEUR DE LA MINUTIERE

T=HAUS  
B=BAS

**SCHEMA DE CÂBLAGE**  
134755500 A