



Freezer

FKFH21F7HW

Frost Free
21 Cu. Ft. Upright



Product Dimensions

Height (Including Hinges)	71-3/8"
Width	32"
Depth (Including Door)	28-5/8"

More Easy-To-Use Features

Built with American Pride

Appliances that are high-performing, more accessible, and more innovative than ever — designed, built, and engineered in the U.S.A.

Quick Freeze

Quickly freeze whatever you store to keep foods at their freshest.

Automatic Alerts

Freezer alerts you if the door is left open or if the temperature rises.

Bright Lighting

Our bright lighting makes it easy to see what's inside.

Store-More™ Tilt-Out Wire Door Bins

Store more in the door — and get easy access with the tilt-out feature.

Store-More™ Adjustable Door Bins

Flexible storage options, with door bins designed to reposition with ease to fit your needs.

SpaceWise® Adjustable Shelf

Easily adjust the shelf up and down to create more space for taller items.

Lock with Pop-Out Key

The freezer key automatically ejects after locking the door so you won't leave it in the door.

Power-On Indicator Light

Know at a glance that your freezer is working.

SpaceWise® Shelf Bookends

Clever and flexible bookends are designed to hold more frozen food containers upright.

Adjustable Temperature Control

Select the correct temperature for your needs.

Signature Features

Ready-Select® Controls with Upfront Display

Easily select options with the touch of a button.

SpaceWise® Organization System

Our SpaceWise® organization system makes it easy to keep food organized and easy to find when you need it. Our organization system includes adjustable and fixed shelves, mid-and-lower level baskets and adjustable door storage options.

Frost Free Operation

Never defrost your freezer again.

ENERGY STAR® Qualified

ENERGY STAR®



Available in:



White (W)

frigidaire.com

Features	
Door Handle Design	Reach-Through
Reversible Door	
Automatic Door Closer	Yes
Leveling Legs	Yes
Lock with Pop-Out Key	Yes
Defrost	Frost Free
Adjustable Temperature Control	Ready-Select®
Front Digital Display	Yes
Temp Display Mode	F/C
High-Temp Duration Readout	Yes
High-Temp Alarm	Yes
Door Ajar Alarm	Yes
Airflow Ports	1
Interior Lighting	Bright
Full-Width Adjustable Shelves	1 Wire
Full-Width Fixed Shelves	3 Wire
Removable Trivet	
SpaceWise® Shelf Bookend	2
Mid-Level Baskets	1
Lower Storage Basket	1
Basket Dividers	
Retractable Pizza Shelf	
Soft Freeze™ Zone	
Store-More™ Adjustable Door Bins	5
Full-Width Door Bins	1
Store-More™ Tilt-Out Wire Door Bins	1
Fixed Door Racks	
Defrost Drain	
Power-On Light	Yes
Convertible	
Certifications	
ENERGY STAR®	Yes
CSA Rating	Household
Specifications	
Total Capacity (Cu. Ft.)	20.5
Shelf Area (Sq. Ft.)	19.30
Annual Energy (kWH)	690
Annual Energy Cost (.1065/kWH)	\$74
Power Supply Connection Location	Lower Right Rear
Voltage Rating	115V
Connected Load (kW rating) @ 115 Volts¹	.58
Amps @ 115 Volts	5
Minimum Circuit Required (Amps)	15
Shipping Weight (Approx.)	258 Lbs.

¹An electrical supply with grounded three-prong receptacle is required. The power supply circuit must be installed in accordance with current edition of National Electrical Code (NFPA 70) and local codes & ordinances.

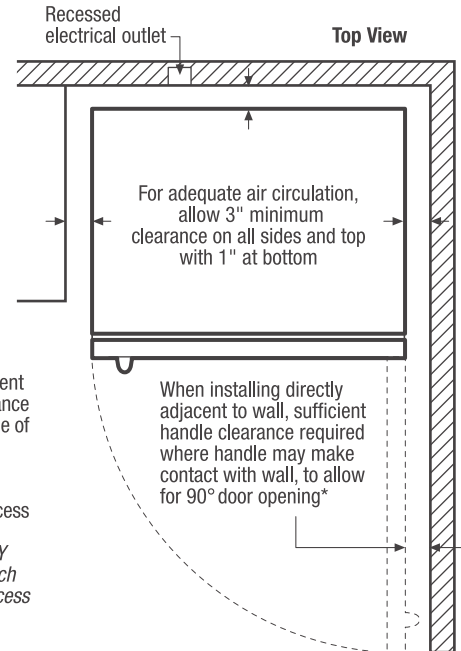
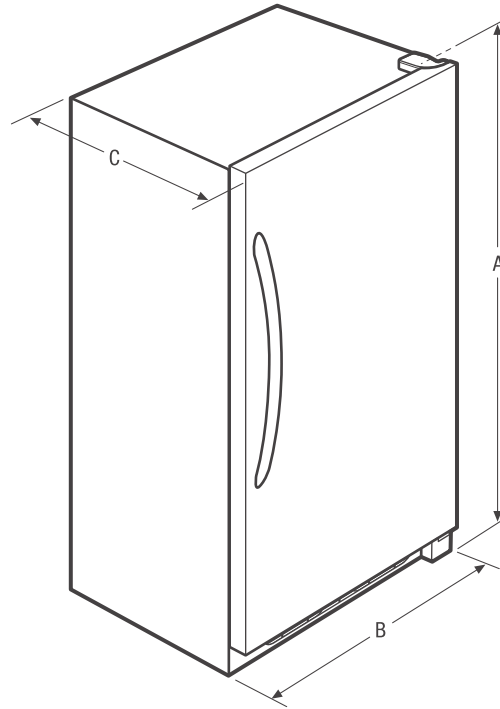

* When installing freezer adjacent to wall, cabinet or other appliance that extends beyond front edge of unit, 20" minimum clearance recommended to allow for optimum 140° door swing, providing complete basket access and removal. (Absolute 3" minimum clearance will ONLY allow for 90° door swing which will provide limited basket access with restricted removal.)

NOTE: For planning purposes only. Always consult local and national electric codes. Refer to Product Installation Guide for detailed installation instructions on the web at frigidaire.com.



Product Dimensions	
A - Height (Including Hinges)	71-3/8"
B - Width	32"
C - Depth (Including Door)	28-5/8"
Depth with Door Open 90°	59-3/8"

Accessories information available on the web at frigidaire.com

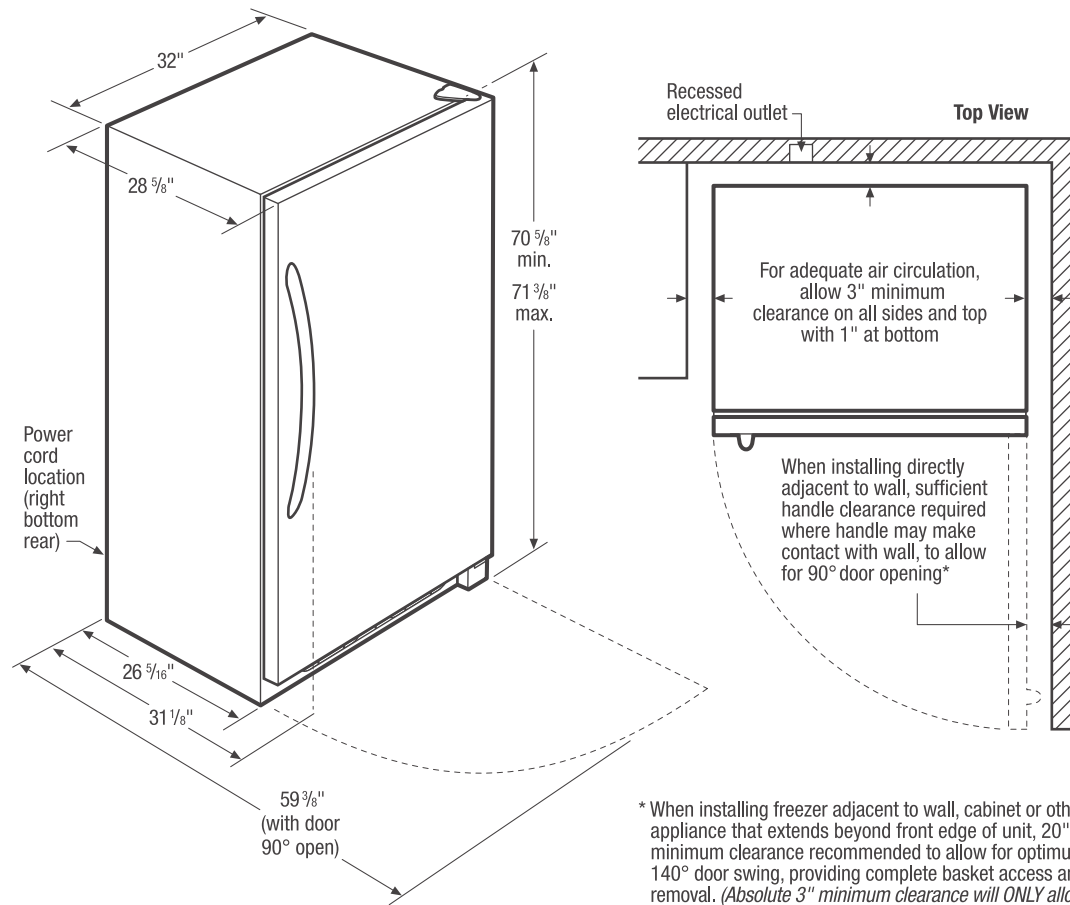

* When installing freezer adjacent to wall, cabinet or other appliance that extends beyond front edge of unit, 20" minimum clearance recommended to allow for optimum 140° door swing, providing complete basket access and removal. (Absolute 3" minimum clearance will ONLY allow for 90° door swing which will provide limited basket access with restricted removal.)

Upright Freezer Specifications

- Product Shipping Weight (approx.) - 258 Lbs.
- An electrical supply with grounded three-prong receptacle is required. The power supply circuit must be installed in accordance with current edition of *National Electrical Code (NFPA 70)* and local codes & ordinances.
- Voltage Rating - 115V
- Connected Load (kW Rating) @ 115 Volts = 0.58 kW
- Amps @ 115 Volts = 5 Amps
- Always consult local and national electric codes.
- For adequate air circulation, allow 3" minimum clearance on all sides and top with 1" at bottom.

- When installing freezer adjacent to wall, cabinet or other appliance that extends beyond front edge of unit, 20" minimum clearance recommended to allow for optimum 140° door swing, providing complete basket access and removal. (Absolute 3" minimum clearance will ONLY allow for 90° door swing which will provide limited basket access with restricted removal.)
- Locate where surrounding air temperature will not exceed 110° F, to ensure optimum performance. (Temperatures 32° F and below will NOT affect operation.)
- All bottom corners of unit MUST rest firmly on solid level surface of hard material, same height as flooring. Surface must be strong and stable enough to support unit when fully loaded.
- Equipped with adjustable leveling legs to ensure unit is level, which is required in order to function properly.

Note: For planning purposes only. Refer to Product Installation Guide on the web at frigidaire.com for detailed instructions.