

Frigidaire

Factory Parts Catalog

Product No.	GHSC39EHPB0	GHSC39EHPW0
Series	counter depth	counter depth
Color	black (smooth)	white (smooth)
Volts	115	115
Wiring Diagram	241638600	241638600
Owner's Guide	241814800	241814800
Market	North America	North America
Energy Guide	241768154	241768154
Service Data Sheet	241639000	241639000

 **Electrolux**

Electrolux Major Appliances
North & Latin America
P.O. BOX 212378
AUGUSTA, GA 30917

Publication No.
5995489910
07/05/02
(EN/SERVICE/KHB)
137

**SIDE-BY-SIDE
REFRIGERATOR**

Model No.
GHSC39EH

Copyright © 2007 Electrolux Home Products, Inc.
All rights reserved.

FREEZER DOOR

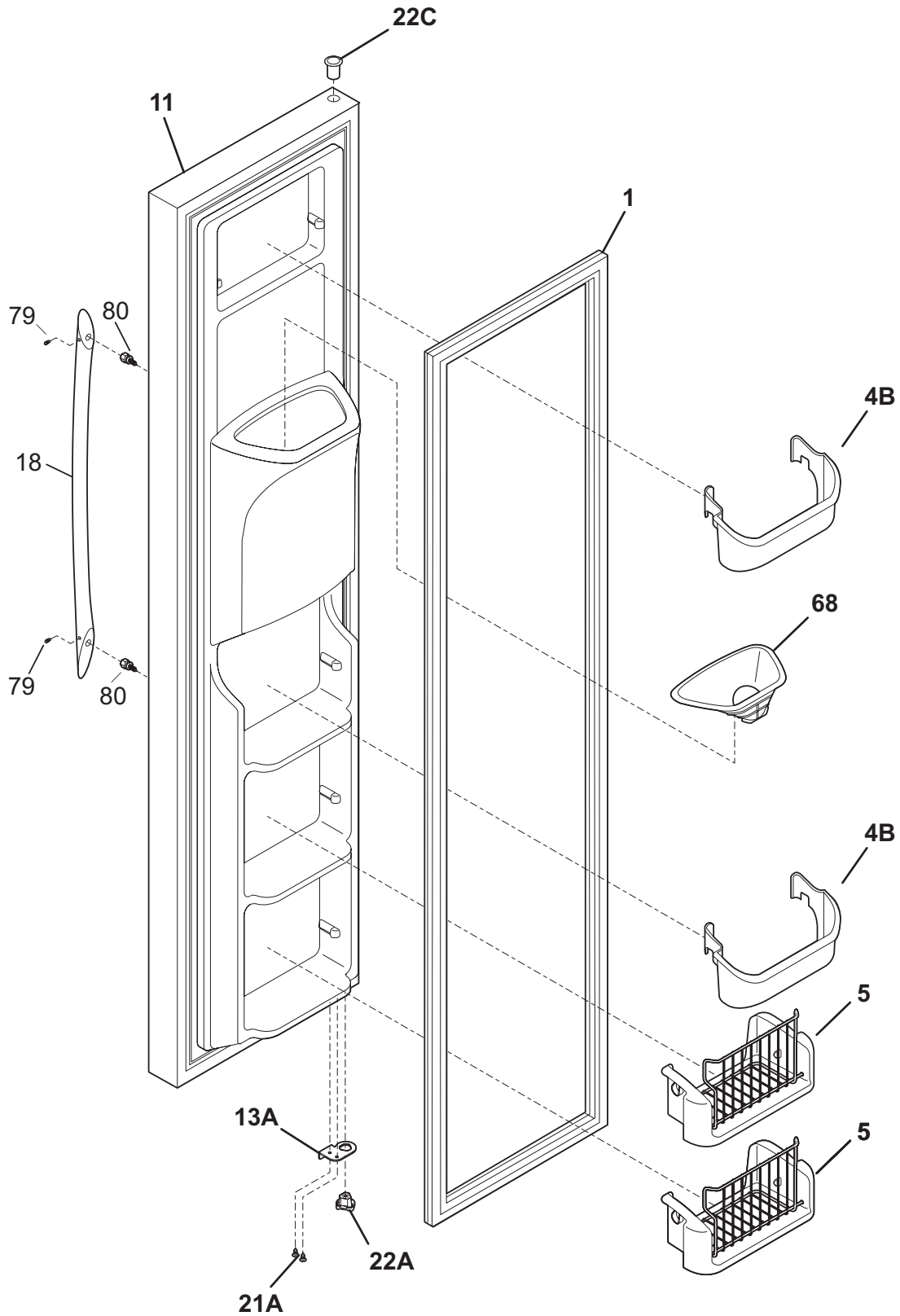

N58FFDBGA1

FREEZER DOOR

Model Index: A GHSC39EHP (GHSC39EHPB0)
 B GHSC39EHP (GHSC39EHPW0)

POS. NO	PART NO.		DESCRIPTION
1 #	241510204	A -	Gasket-frzr door, black, magnetic
1 #	241510202	- B	Gasket-frzr door, white, magnetic
4B	241511606	A B	Bin-door, pseudo, frzr
5	241545001	A B	Bin-tilt out, tilt-out
11	241526790	A -	Door-frzr, black, complete assy
11	241526789	- B	Door-frzr, white, complete assy
13A	240581906	A -	Door Stop, black, frzr
13A	240581902	- B	Door Stop, white, frzr
18	240536810	A -	Handle-door, black
18	240536809	- B	Handle-door, white
21A	240598402	A B	Screw, 10-32 x 1/2
22A	240328204	A -	Bearing-hinge(frz), black, closer
22A	240328202	- B	Bearing-hinge(frz), closer
22C	240328404	A -	Bearing-hinge, black, upper
22C	240328402	- B	Bearing-hinge, natural, upper
68	241525101	A B	Chute-ice
79	218755402	A B	Screw-set, 10-32 x 0.375
80	218755504	A B	Screw-shoulder, #10 AB, handle mounting
*	240552102	A B	Harness-wiring, door
*	241806601	A B	Connector-water, straight
*	5303918256	A B	Dispenser heater kit

REFRIGERATOR DOOR

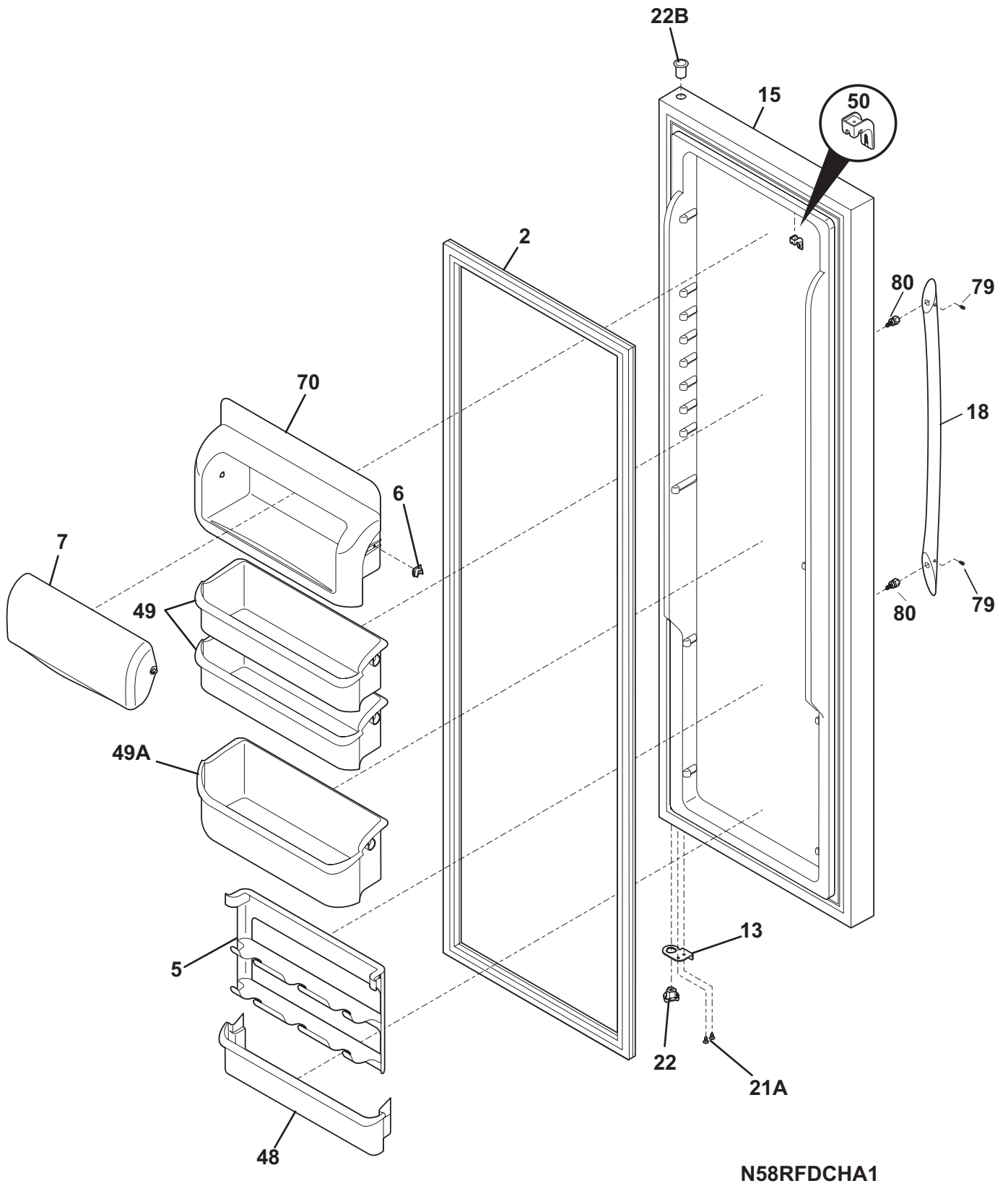

REFRIGERATOR DOOR

Model Index: A GHSC39EHP (GHSC39EHPB0)
 B GHSC39EHP (GHSC39EHPW0)

POS. NO	PART NO.		DESCRIPTION
2 #	241510203	A -	Gasket-refr door, black, magnetic
2 #	241510201	- B	Gasket-refr door, white, magnetic
5	241516102	A B	Rack-can
6	241515901	A B	Lug-dairy compartment
7	241515601	A B	Door-dairy
12	241808601	A B	Label-nameplate
13	240581905	A -	Door Stop, black, ref
13	240581901	- B	Door Stop, white, refr
15	241534585	A -	Door-refr, black, complete assy
15	241534584	- B	Door-refr, white, complete assy
18	240536810	A -	Handle-door, black
18	240536809	- B	Handle-door, white
21A	240598402	A B	Screw, 10-32 x 1/2
22	240328203	A -	Bearing-hinge, black, closer
22	240328201	- B	Bearing-hinge(ref), closer
22B	240328404	A -	Bearing-hinge, black, upper
22B	240328402	- B	Bearing-hinge, natural, upper
48	241511704	A B	Bin-door, ref
49	241505304	A B	Bin-door, 2-liter
49*	241779901	A B	Liner, bin, 2 liter
49A	241505504	A B	Bin-door, gallon
49A*	241780001	A B	Liner, bin, gallon
50	241508401	A B	Cover-magnet
70	241515801	A B	Compartment-dairy, removable
79	218755402	A B	Screw-set, 10-32 x 0.375
80	218755504	A B	Screw-shoulder, #10 AB, handle mounting

CABINET

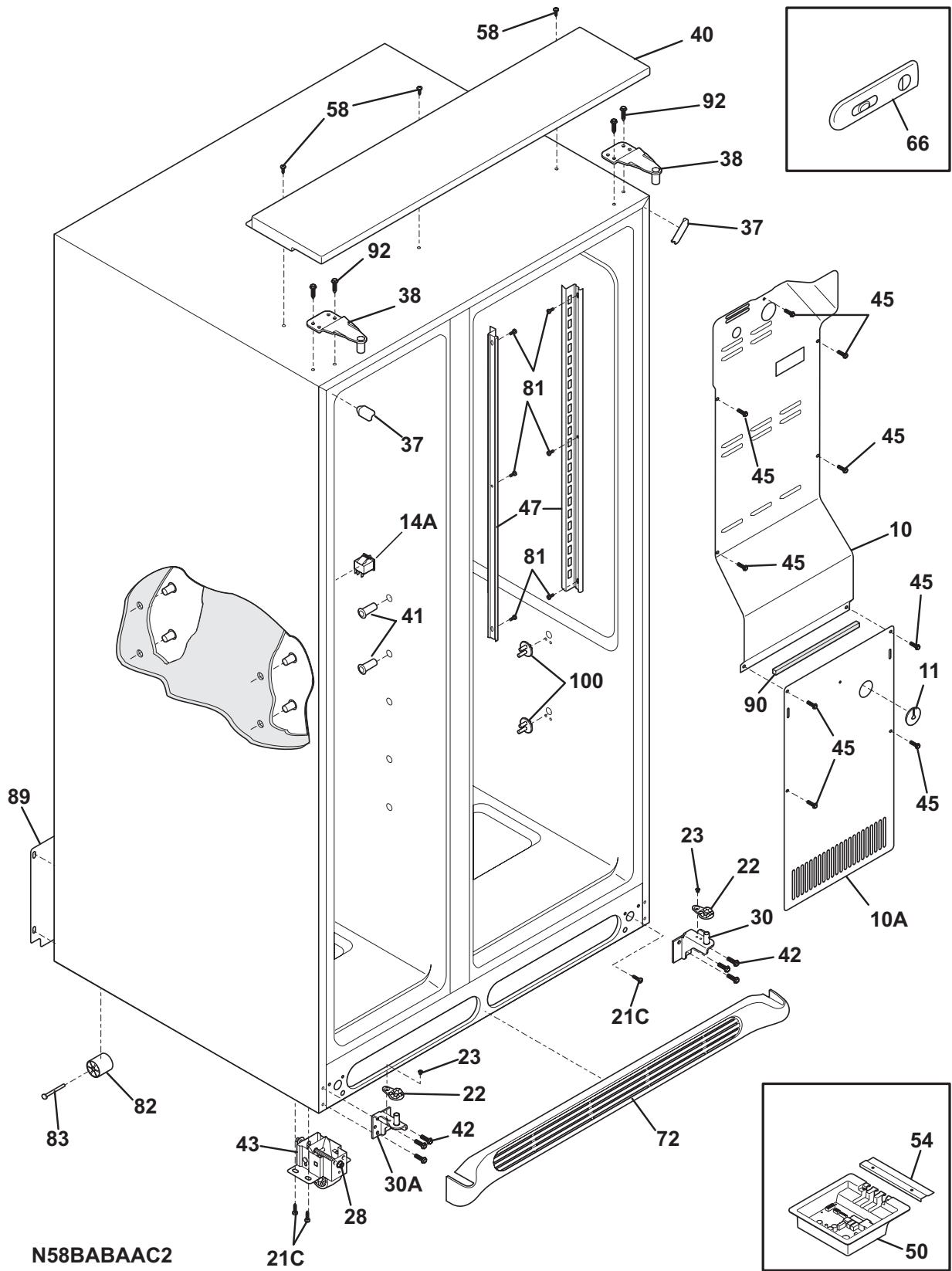

CABINET

Model Index: A GHSC39EHP (GHSC39EHPB0)
B GHSC39EHP (GHSC39EHPW0)

POS. NO	PART NO.		DESCRIPTION
10	241509804	A B	Cover-air duct
10A	240475911	A B	Cover-evap coil, lower
11	5303208309	A B	Plug-hole, factory test
14A	241547901	A B	Switch-light/lamp, frzr door
21C	218252201	A B	Screw, #8 truss hd, 10-32CA x 0.500
22	240457702	A -	Plate-door closer
22	240457701	- B	Plate-door closer
23	240402702	A B	Screw-#10-32 x 1/4 flat hd
28	240335502	A B	Bolt-roller adj, hex washer head, 1/4-20 x 4.020, (2), special
30	241603703	A B	Bracket-lower hinge, ref
30A	241603704	A B	Bracket-lower hinge
37	240337610	A -	Trim-cabinet corner, black, (2)
37	240337608	- B	Trim-cabinet corner, white, (2)
38	240327207	A B	Bracket-upper hinge
40	241555103	A -	Cover-hinge, black
40	241555101	- B	Cover-hinge
41	241550801	A B	Grommet-shelf mtg, 1.40" long
41*	241550701	A B	Grommet-shelf mtg, .96" long
42	240578902	A B	Screw-hinge mtg, hex head, 1/4-20 x 5/8
43	240335005	A B	Roller Assy, adjustable, front, (2)
45	241500303	A B	Screw, hex washer head, 8-18AB x 0.500
47	241513001	A B	Channel-shelf mtg, side, (2)
50	241511102	A B	Board-main power
50*	241524802	A B	Seal, housing
50*	241532501	A B	Clip-harness
54	241532401	A B	Channel
58	241595402	A B	Screw-#10-32 X 3/4
66	241513601	A B	Damper Assy
72	241521619	A -	Grille/Kickplate, black
72	241521617	- B	Grille/Kickplate, white
81	5304455650	A B	Screw, hex washer head, 8-15A x 0.625, low profile
82	5304418225	A B	Roller, compressor base, rear, (2)
83	5304455655	A B	Rivet, flat head, 1/4 OD x 1-3/4, roller pin
89	241733902	A B	Cover-access, w/label
90	218249808	A B	Seal-coil cover
92	241710601	A B	Screw, hex washer hd, 1/4 x 7/8, hinge mtg
100	240423701	A B	Support, crisper cover, front, (4)
100*	240350802	A B	Support, crisper cover, rear, (4)
*	241591701	A B	Louver
*	5303321321	A -	Paint, touch-up, black
*	5303321319	- B	Paint, touch-up, white

SHELVES

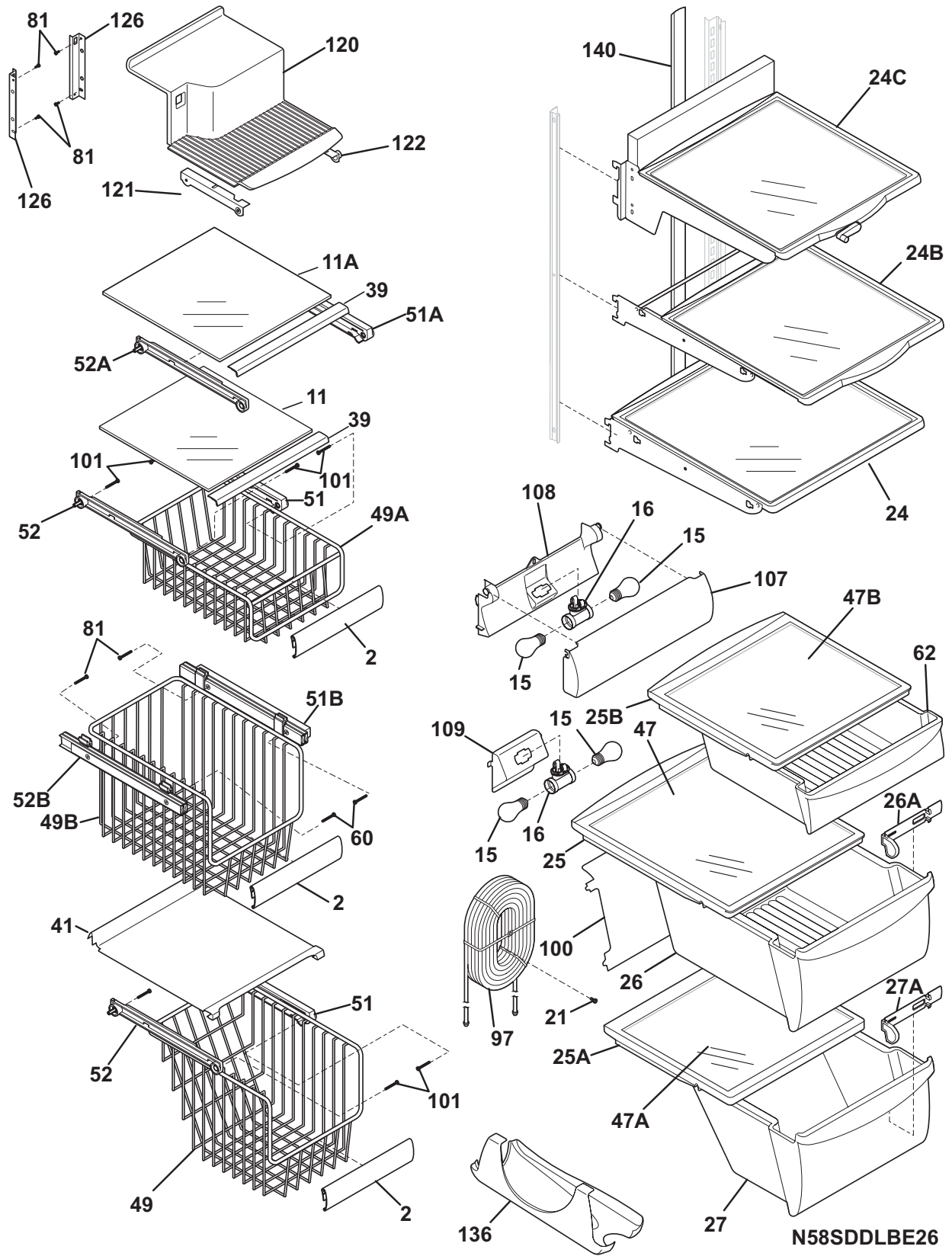

SHELVES

		<i>Model Index:</i>	
		A GHSC39EHP (GHSC39EHPB0)	
		B GHSC39EHP (GHSC39EHPW0)	
POS. NO	PART NO.		DESCRIPTION
2	241510605	A B	Trim-basket
11	241711213	A B	Shelf-freezer, glass, lower
11A	241711214	A B	Shelf-freezer, glass, upper
15	241552801	A B	Light Bulb
16	241622802	A B	Socket-light
16*	241513102	A B	Harness-wiring
21	5304455658	A B	Screw, hx wshr hd sems, 8-15A x 0.625, 21
24	240355239	A B	Shelf-"Spill-Safe", fixed
24B	240350126	A B	Shelf-"Spill-Safe", cantilever, sliding
24C	240424611	A B	Shelf-"Spill-Safe", sliding, "Aspect", complete
25	240599302	A B	Cover-crisper pan, upper
25*	240362101	A B	Clip-slide, cover-crisper
25A	240350902	A B	Cover-crisper pan, lower
25B	240599801	A B	Cover-meat pan
26	240351041	A B	Pan-crisper, upper
26*	240349801	A B	Clip-slide, pan-crisper
26*	240423301	A B	Divider-crisper pan
26*	241595202	A B	Clip-slide, pan-crisper
26A	241638201	A B	Control-humidity
26A*	241638101	A B	Frame-humidity control
27	240351218	A B	Pan-crisper, lower
27A	240362201	A B	Control-humidity
39	240367603	A B	Trim-shelf, 11.65", front
41	241637601	A B	Baffle-air
47	241711237	A B	Insert-pan cover, glass
47A	240350603	A B	Insert-pan cover, glass
47B	241711239	A B	Insert-pan cover, glass
49	241515001	A B	Basket-sliding
49A	241528001	A B	Basket-sliding, upper, half
49B	241514901	A B	Basket-sliding, upper, full
51	241514501	A B	Hanger-basket, RH
51A	241514701	A B	Hanger-shelf glass, RH
51B	240579803	A B	Hanger-basket, RH
52	241514601	A B	Hanger-basket, LH
52A	241514801	A B	Hanger-shelf glass, LH
52B	240579804	A B	Hanger-basket, LH
60	218362501	A B	Screw, hex washer head, 8-18AB x 1.250, spacer, (2)
62	240599704	A B	Pan-meat
81	5304455650	A B	Screw, hex washer head, 8-15A x 0.625, low profile
97	241532002	A B	Water Tank
100	240326304	A B	Cover-water tank
101	218493101	A B	Screw, hex washer head, 8-18AB x 1-3/4
107	241513402	A B	Shield-light, meat pan
108	241513301	A B	Cover-wiring, crisper light
109	241513202	A B	Base-crisper light socket
120	241691701	A B	Shelf-ice cream
121	241504701	A B	Rail-ice cream shelf, LH
122	241504702	A B	Rail-ice cream shelf, RH
126	241674401	A B	Channel, auger mtg, LH
126	241674402	A B	Channel, auger mtg, RH
136	240424502	A B	Dispenser-can, clear
140	240430505	A B	Channel, wtr tube cover
*	241768154	A B	Energy Guide

CONTROLS

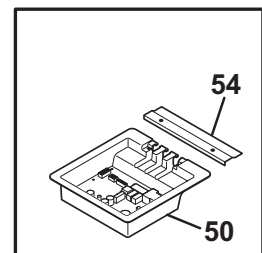
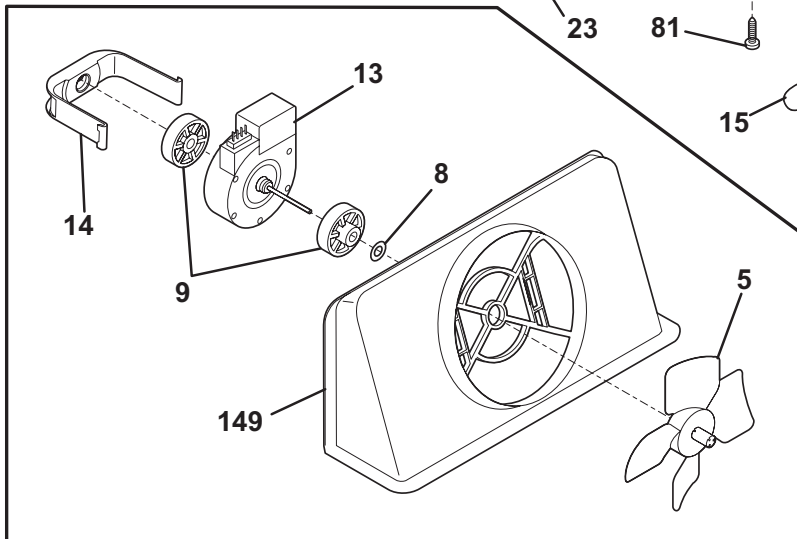
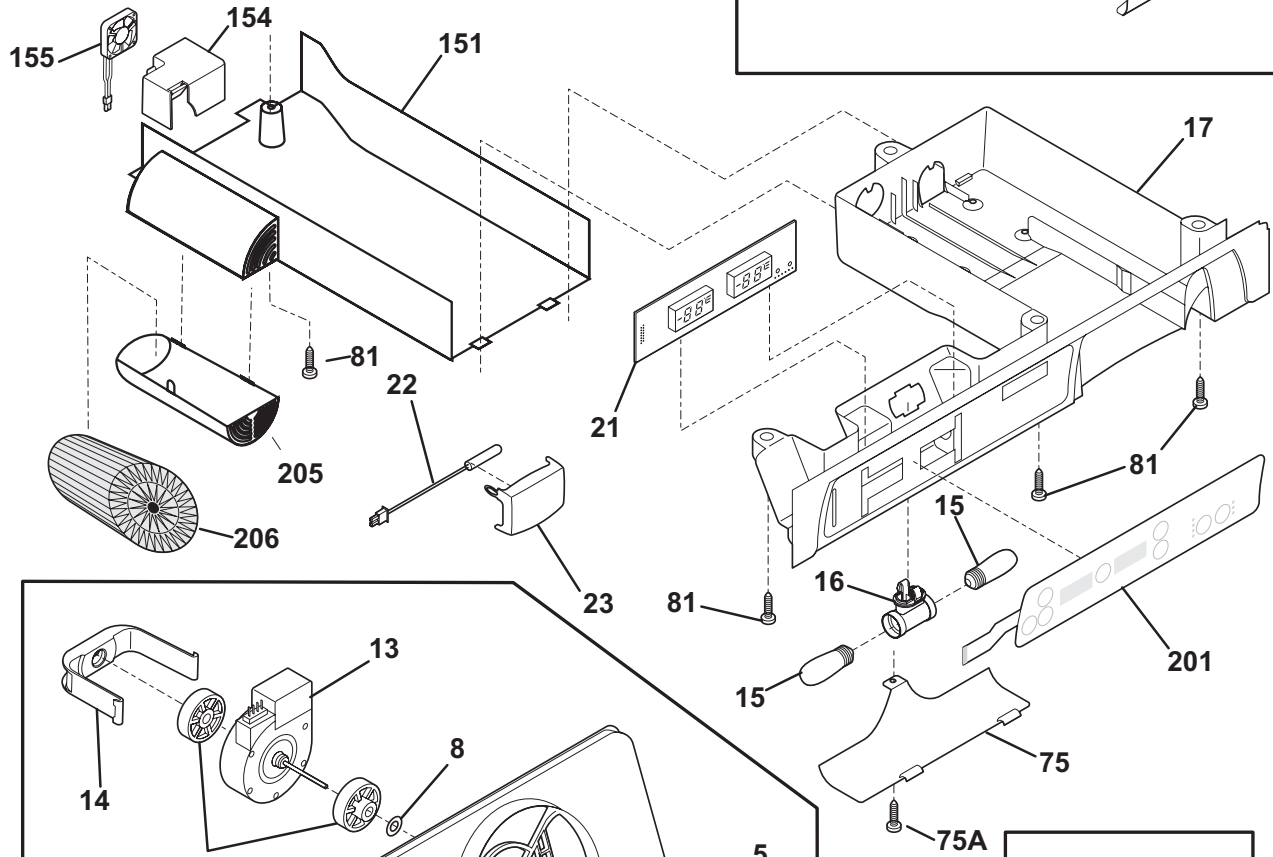
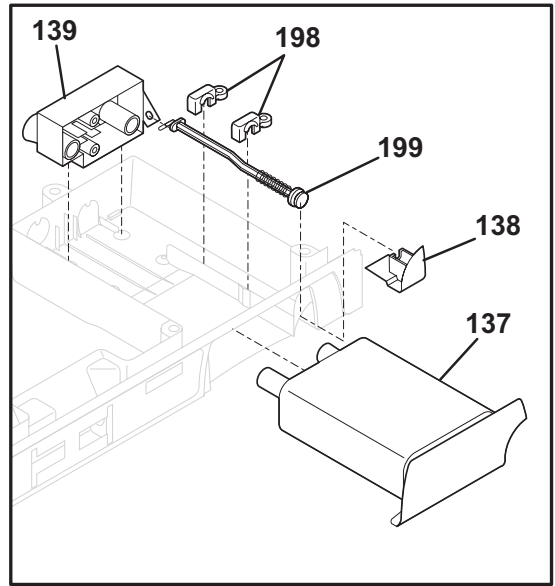
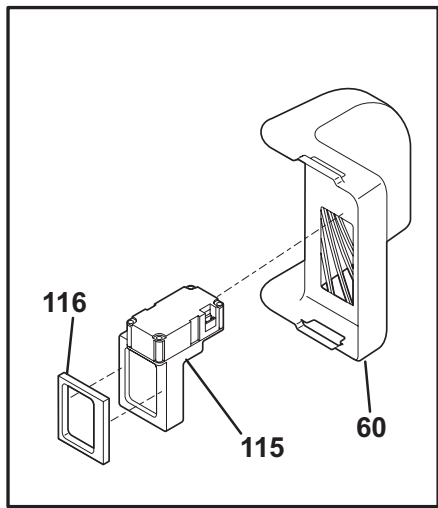

N58TBBAAB5

CONTROLS

Model Index: A GHSC39EHP (GHSC39EHPB0)
 B GHSC39EHP (GHSC39EHPW0)

POS. NO	PART NO.		DESCRIPTION
5 #	5308000010	A B	Fan Blade, red, evaporator fan
8	215474201	A B	Washer, "slinger", nylon, evap fan shaft
9	241518301	A B	Bushing, motor mounting
13	241509402	A B	Motor, evaporator fan
13*	241510501	A B	Seal-diffuser
14	241517701	A B	Clip, evap fan motor
15	241552801	A B	Light Bulb
16	241622802	A B	Socket-light
17	241516201	A B	Box-control, front
17*	241510801	A B	Harness-wiring
21 #	240596701	A B	Control, electronic
22	240597203	A B	Sensor
23	241512901	A B	Cover-sensor
50	241511102	A B	Board-main power
50*	241524802	A B	Seal, housing
50*	241532501	A B	Clip-harness
54	241532401	A B	Channel
60	241510301	A B	Diffuser-air
75	241517802	A B	Shield-light
75A	5304455650	A B	Screw, hex washer head, 8-15A x 0.625, low profile
81	5304455658	A B	Screw, hx wshr hd sems, 8-15A x 0.625, 21
115	241518501	A B	Damper, motorized
116	241518601	A B	Seal-damper, foam
137	240396401	A B	Filter, water, carbon cassette, front, with o'rings
137*	240396701	A B	Bypass, water filter, Optional Part
138	240397301	A B	Button-filter release
139	240396002	A B	Base-water filter
139*	240526901	A B	O-ring, wtr filter base
149	241517601	A B	Shroud-evap fan mtg
149*	241528304	A B	Seal, foam, evap fan assy
151	241526001	A B	Filter housing
154	241525801	A B	Duct-air
155	241526102	A B	Motor-air filter
155*	241527202	A B	Harness-wiring, filter fan
198	240397401	A B	Retainer
199*	240398401	A B	Spring-filter release rod
201	241816702	A B	Switch-membrane
205	241525901	A B	Air Filter Door
206	241504902	A B	Filter-air
*	3205266	A B	Edge Protector, wiring harness
*	241537401	A B	Shield

SYSTEM

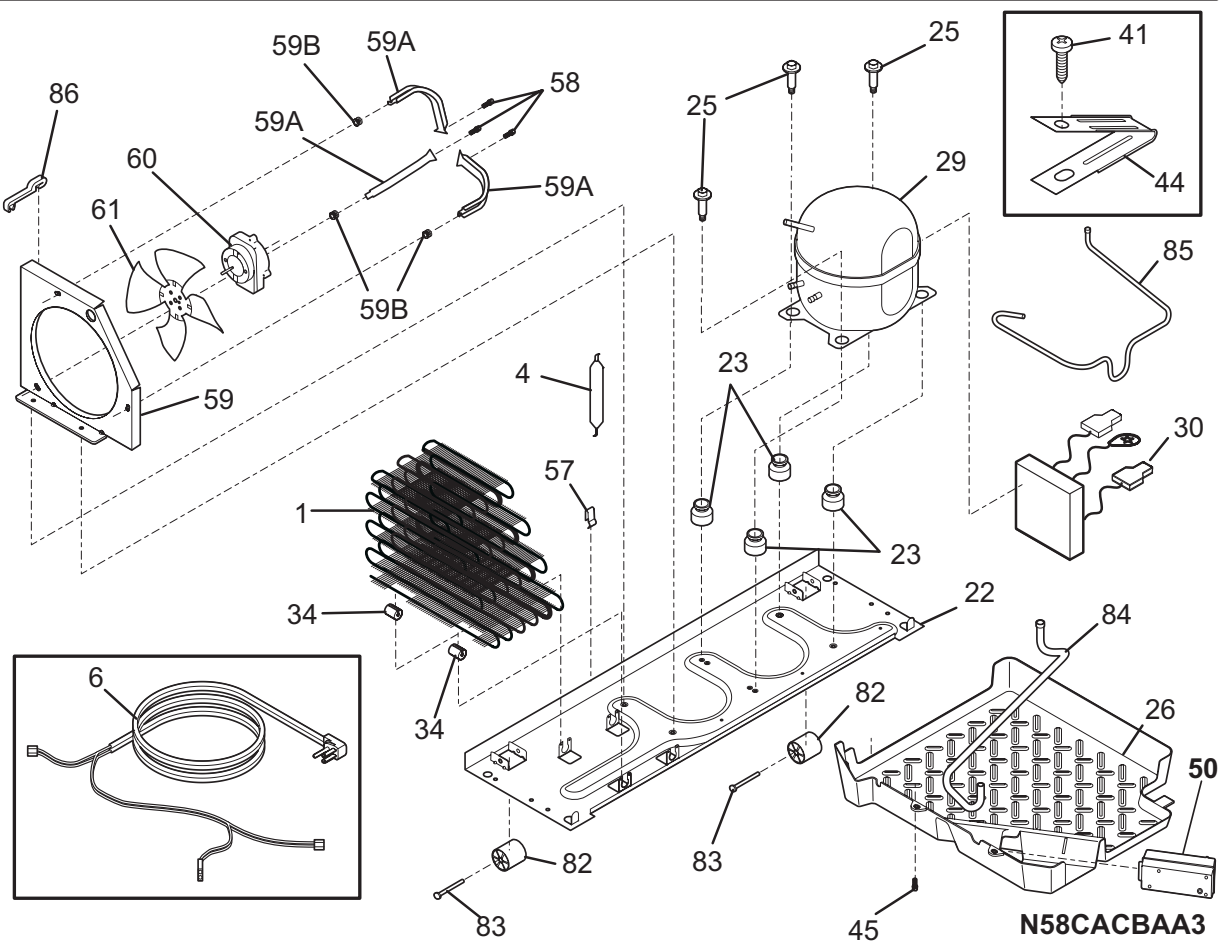
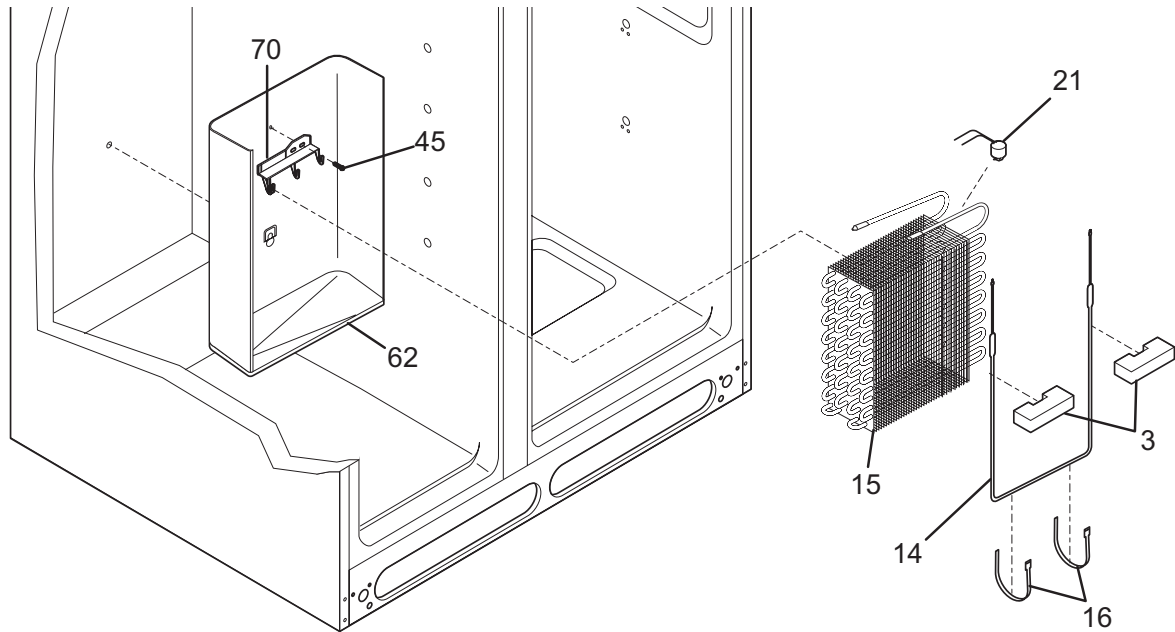

SYSTEM

Model Index: A GHSC39EHP (GHSC39EHPB0)
 B GHSC39EHP (GHSC39EHPW0)

POS. NO	PART NO.		DESCRIPTION
1	240333603	A B	Condenser
3	218679607	A B	Block-evap coil, styrofoam, (2)
4 #	218944001	A B	Drier-filter, R134a System
6 #	241516901	A B	Cord-service
6*	241510801	A B	Harness-wiring
6* #	241519902	A B	Harness-wiring
6* #	241636203	A B	Harness-wiring, machine compt
14 #	240316107	A B	Heater-defrost
15 #	5303918284	A B	Evaporator Kit
16	5308000110	A B	Strap-evap/heater, aluminum, (2)
21	5303918214	A B	Thermostat-defrost, kit
22	240330011	A B	Base-compressor mtg
22*	218252201	A B	Screw, #8 truss hd, 10-32CA x 0.500
23	218513300	A B	Grommet-compr mtg, (4)
25	240491503	A B	Screw-compressor mtg, 1/4-28 x 1.16, (4)
26	241697501	A B	Pan-defrost drain
29 #	241547601	A B	Compressor, w/electricals
30	241577501	A B	Invertor
34	240405201	A B	Grommet, rubber, black, cond tube/wire
41	240555002	A B	Screw-#8-32 X 3/8
44	215174700	A B	Clamp-service cord, strain relief, galv steel
45	5304455650	A B	Screw, hex washer head, 8-15A x 0.625, low profile
50	241635501	A B	Housing-control, apollo lighting
50*	241641501	A B	Screw
57	240542601	A B	Clip-wiring harness
58	240433203	A B	Screw, hex washer head, 8-18 x 3/8
59	240315502	A B	Shroud-cond fan
59*	240346701	A B	Tape-foam seal, shroud
59*	240359403	A B	Screw-fan shroud, (2)
59A	240346501	A B	Bracket-support, cond mtr, (3)
59B	240346601	A B	Grommet-bracket, (3)
60 #	241584301	A B	Motor-condenser fan
61	241639501	A B	Blade-condenser fan
62	240429402	A B	Trough-drain
70	218990801	A B	Bracket-evap/cvr mtg
82	5304418225	A B	Roller, compressor base, rear, (2)
83	5304455655	A B	Rivet, flat head, 1/4 OD x 1-3/4, roller pin
84	5304421068	A B	Tube-drain, lower
85	241719501	A B	Tube-connector, suction
86	240409302	A B	Spacer-cond tube, black
* #	5303918327	A B	Heat Exchanger Kit, suction line
*	5303918222	A B	Hot Tube Repair Kit, service

ICE & WATER DISPENSER

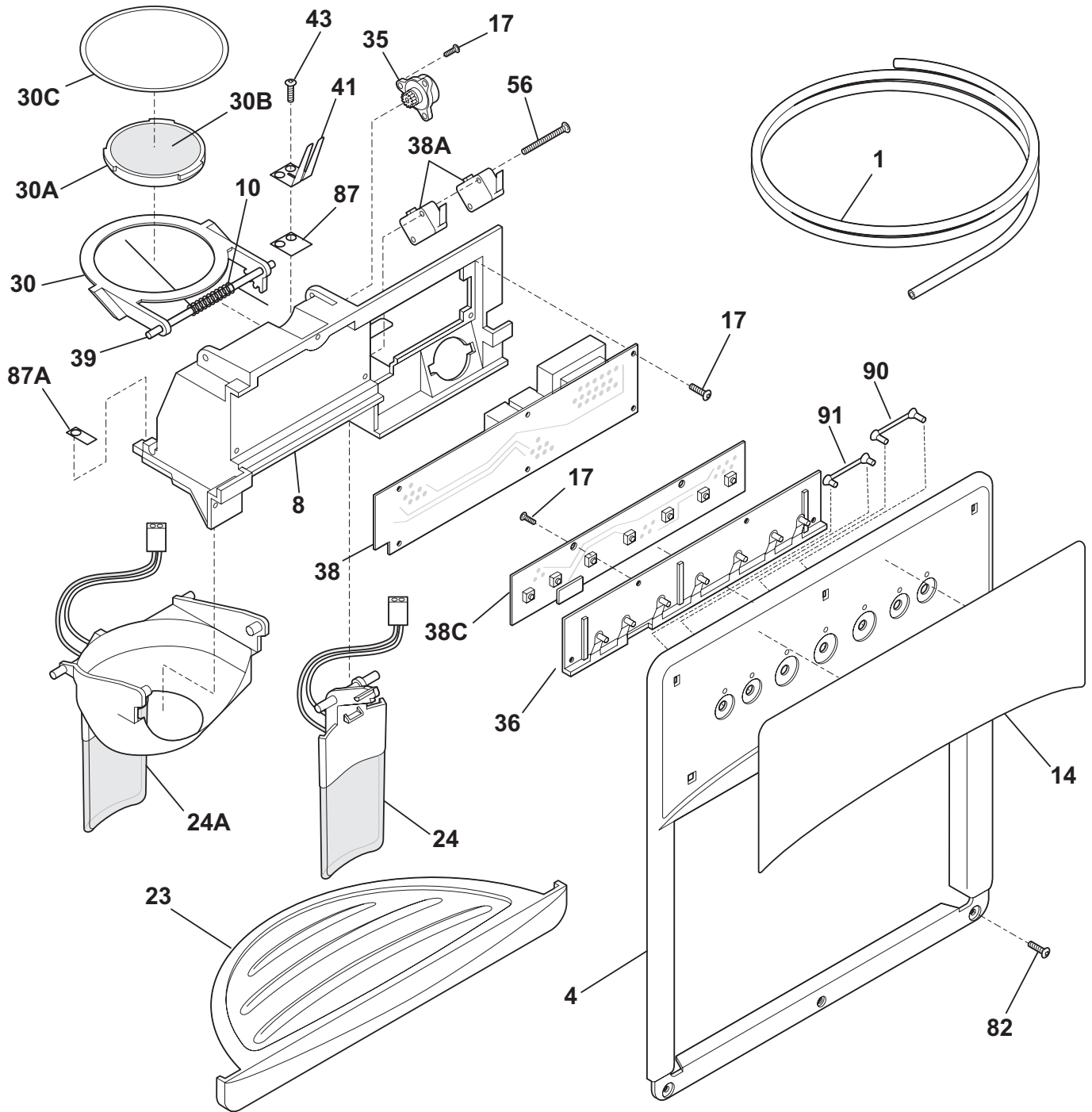

N58XEAAA1

ICE & WATER DISPENSER

Model Index: A GHSC39EHP (GHSC39EHPB0)
B GHSC39EHP (GHSC39EHPW0)

POS. NO	PART NO.		DESCRIPTION
1	218976409	A B	Tube, water, door
1*	218976901	A B	Tube, water inlet, valve to IM
1*	218976903	A B	Tube-water inlet, inlet valve, to filter
1*	218976917	A B	Tube-water inlet, valve to door
1*	240561702	A B	Seal-water inlet, inlet valve, to ice maker
4	241678703	A -	Cover-module, black
4	241678701	- B	Cover-module, white
8	241680503	A -	Module-dispenser, black
8	241680501	- B	Module-dispenser, white
10	241688901	A B	Spring-torsion
14	240323969	A -	Label-module cover, black
14	240323967	- B	Label-module cover, white
17	241679801	A B	Screw
23	241649003	A -	Drip Tray, black
23	241649001	- B	Drip Tray, white
24	241685703	A -	Actuator-water, black
24	241685701	- B	Actuator-water, white
24A	241682303	A -	Actuator-ice, black
24A	241682301	- B	Actuator-ice, white
30	241688401	A B	Door Assy-ice chute
30A	241688501	A B	Door center
30B	241688601	A B	Insulation-door
30C	241688701	A B	Door seal
35	241689301	A B	Damper-rotary
36	241680301	A B	Carrier
38 #	241708102	A B	Board-power
38A#	241689101	A B	Switch-micro, single pole, double throw
38C#	241708307	A B	Board-control
38C*	241680001	A B	Harness-ribbon cable
39	241688801	A B	Pin-hinge
41	241689001	A B	Spring-actuator
43	215296301	A B	Screw, plask h/l, #6 x 3/8
56	241689201	A B	Screw-micro switch, pan head
82	240363402	A B	Screw-#8-18 X 1/2, #6 hd plask
87	241688302	A B	Bearing Plate
87A	241688301	A B	Bearing Plate
90	241680201	A B	Light Pipe, reflector, long
91	241680101	A B	Light Pipe, reflector, short
*	5303918256	A B	Dispenser heater kit
*	241686201	A B	Insulator-electrical

ICE CONTAINER

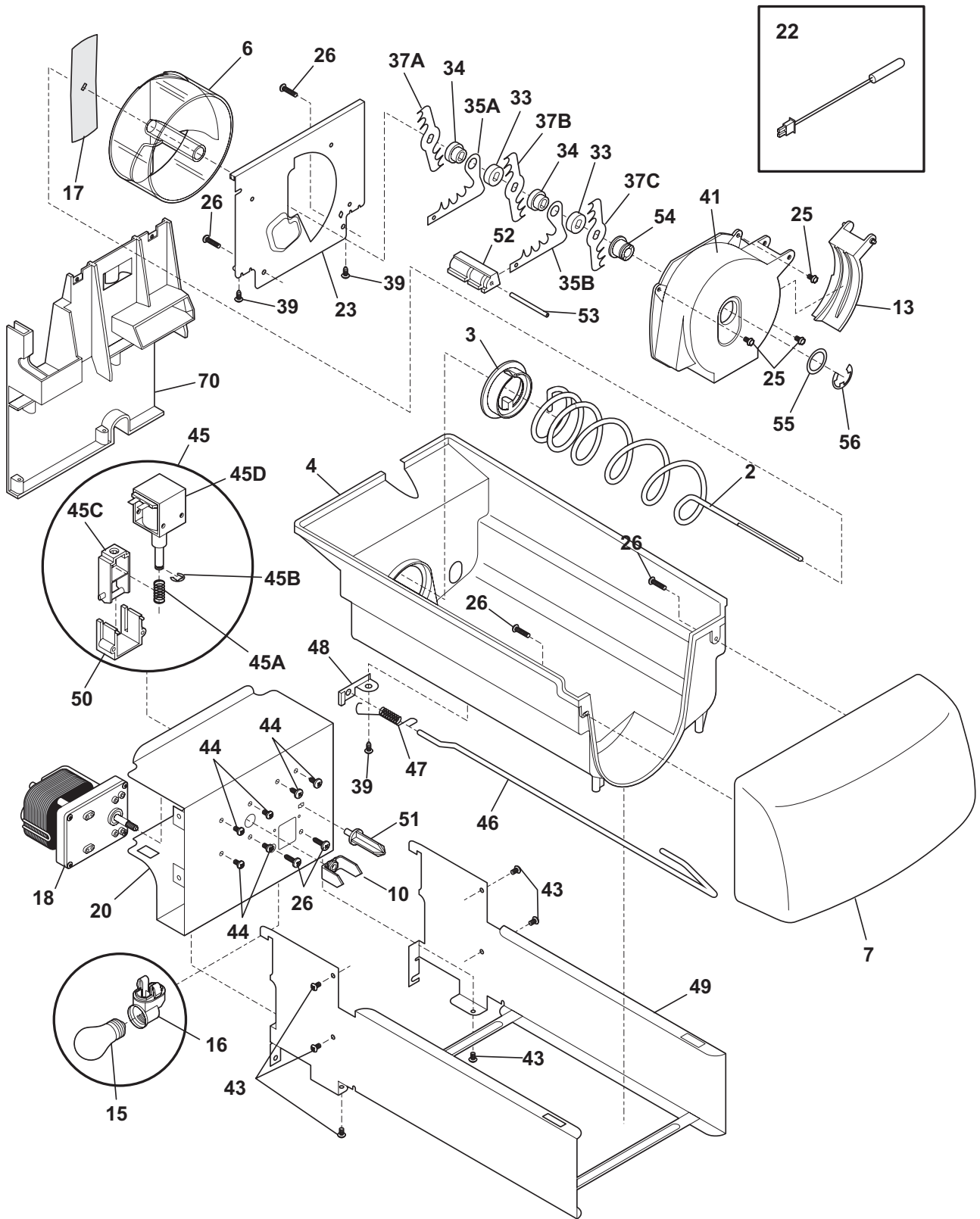

N58YDAAAC4

ICE CONTAINER

Model Index: A GHSC39EHP (GHSC39EHPB0)
B GHSC39EHP (GHSC39EHPW0)

POS. NO	PART NO.		DESCRIPTION
2	241684701	A B	Auger-ice
3	241685201	A B	Cam-drive
4	241515202	A B	Ice Bucket Assy
6	241685101	A B	Drum-ice disp
7	241515301	A B	Front-ice container
10	241726501	A B	Bar-drive
13	241685301	A B	Gate
15	241555401	A B	Light Bulb
16	241559801	A B	Socket-light
17	241684501	A B	Drive Blade
18 #	241676202	A B	Motor-auger, 115V
18*	241522901	A B	Harness-wiring, icmkr/container
20	241675502	A B	Cover-motor
22	240597203	A B	Sensor
22*	241519401	A B	Clip, sensor
23	241684001	A B	Plate-front
25	241690701	A B	Screw, hex washer head, 8-32T x 0.375
26	215503205	A B	Screw, cr pan hd, 10-16 x 0.500
33	241684801	A B	Spacer
34	241689801	A B	Spacer
35A	241684301	A B	Fixed Blade, round
35B	241684201	A B	Fixed Blade, square
37A	241684101	A B	Blade, crusher #1
37B	241684102	A B	Blade, crusher #2
37C	241684103	A B	Blade, crusher #3
39	241690501	A B	Screw
41	241685601	A B	Housing-crusher
43	215005101	A B	Screw, hanger/rlr mtg, 8-10 x 7/16
44	218359202	A B	Screw, pan head, 8-32 x 0.250
45 #	241675701	A B	Solenoid Assy, 115V
45A	241675901	A B	Spring-solenoid
45B	241676001	A B	E-Ring-solenoid
45C	241676101	A B	Actuator-solenoid
45D#	241675801	A B	Solenoid, 115V
46	241684402	A B	Control Rod
47	241731801	A B	Spring-control rod
48	241684602	A B	Bracket-control rod
49	241676501	A B	Rail Assy
50	241675601	A B	Guide-solenoid
51	241676301	A B	Rotation Stop
52	241684901	A B	Spacer-fixed blades
53	241690402	A B	Pin-spiral, fixed blades
54	241685001	A B	Nut-auger
55	241690306	A B	Washer
56	241690201	A B	E-ring
70	241504601	A B	Plate-mounting
70*	241551601	A B	Screw, hex head, 8-18B x 0.875
70*	241716801	A B	Clip
*	240562101	A B	Insulator
*	241504303	A B	Ice Container Assy, w/moving parts

ICE MAKER

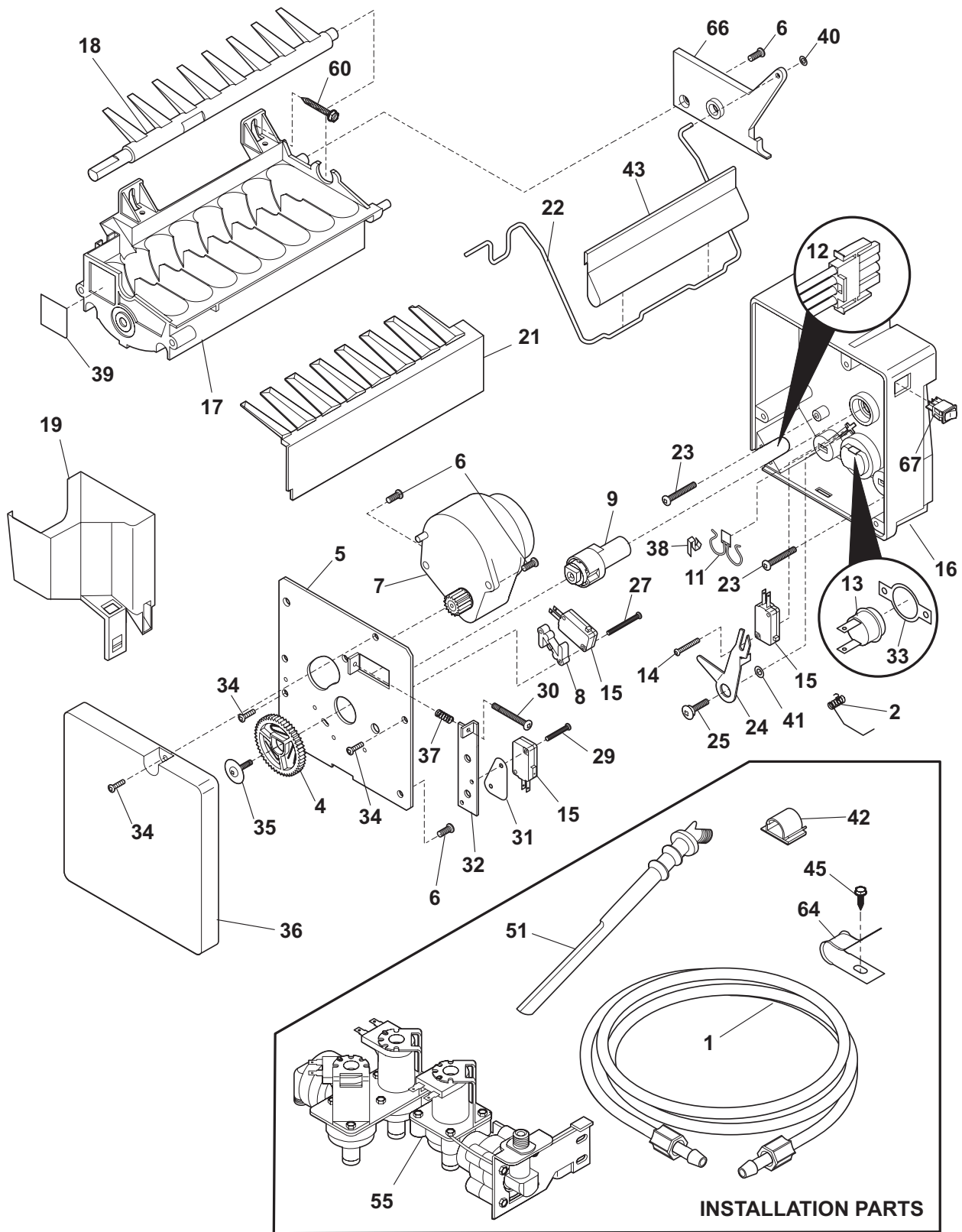

N58115TServo

ICE MAKER

Model Index: A GHSC39EHP (GHSC39EHPB0)
B GHSC39EHP (GHSC39EHPW0)

POS. NO	PART NO.		DESCRIPTION
1	218976409	A B	Tube, water, door
1*	218976901	A B	Tube, water inlet, valve to IM
1*	218976903	A B	Tube-water inlet, inlet valve, to filter
1*	218976917	A B	Tube-water inlet, valve to door
1*	240561702	A B	Seal-water inlet, inlet valve, to ice maker
2	5304456650	A B	Spring-shutoff arm, ICE MAKER
4	5304458380	A B	Gear
5	5304458383	A B	Plate-mounting
6	5304458386	A B	Screw
7 #	5304458382	A B	Motor-ice maker Svo
8	5304458388	A B	Spacer-hold switch
9	5304456662	A B	Cam
11 #	5304458400	A B	Thermal Cutoff, ICE MAKER
12	5304458379	A B	Harness-wiring
13	5304456665	A B	Thermostat, ICE MAKER
14	5304458384	A B	Screw
15 #	5304456667	A B	Switch-micro, (3)
16	5304458395	A B	Housing, control
17	5304456669	A B	Mold-ice maker, w/therm cut off
18	5304458377	A B	Ejector-ice
18*#	240352601	A B	Wiring Harness, internal, with plug
19	5304458378	A B	Cup-water inlet
21	5304458390	A B	Ice Stripper
22	5304458375	A B	Shut-off Arm
23	5304458394	A B	Screw
24	5304458391	A B	Lever Arm
25	5304456676	A B	Screw, M 4x12.8 #2, lever arm/spr
27	5304458385	A B	Screw
29	5304458393	A B	Screw
30	5304458387	A B	Screw
31	5304458381	A B	Insulator
32	5304456681	A B	Plate-valve switch
33	5304458403	A B	Retainer-thermostat
34	5304456678	A B	Screw, M 3x12 #3, (2)
35	5304456684	A B	Screw
36	5304458376	A B	Cover-ice maker
37	5304456682	A B	Spring, shut-off arm
38	5304458398	A B	Clip
39	5304458399	A B	Conductor-heat
40	5304458401	A B	Clip-retainer
41	5304458389	A B	Washer
42	218515403	A B	Clip-grille
43	241720601	A B	Extension
45	5304455650	A B	Screw, hex washer head, 8-15A x 0.625, low profile
51	241796402	A B	Tube-water fill, extension
55 #	240531101	A B	Valve-water, triple solenoid
55*	218709101	A B	Screw, hex head, 10-32 x 0.500
55*	240363602	A B	Screw-shoulder
55*	240542901	A B	Cap-water valve

ICE MAKER

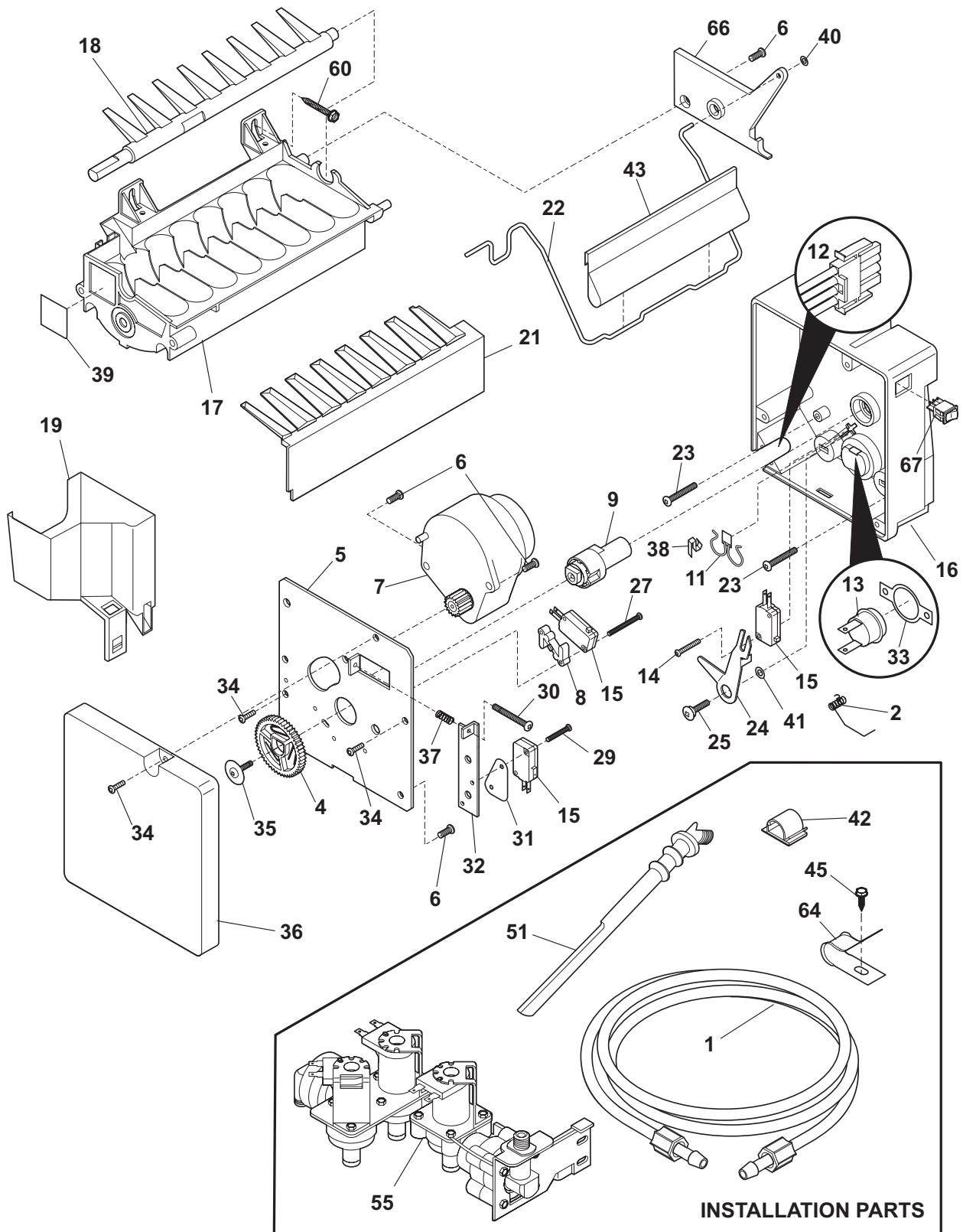

N58115TServo

ICE MAKER

Model Index: A GHSC39EHP (GHSC39EHPB0)
 B GHSC39EHP (GHSC39EHPW0)

POS. NO	PART NO.		DESCRIPTION
60	5304455651	A B	Screw, hex washer head, 8-15A x 0.500
64	5304455846	A B	Clamp, .31 ID, steel, water tube
66	5304458374	A B	Bracket-ice maker
67	5304458392	A B	Switch-on/off
*	218888001	A B	Adapter, water line, w/fittings
*	241583301	A B	Deflector-air, ICE MAKER
*	241806601	A B	Connector-water, straight
*	5304456660	A B	Screw, M 4x6 #2
*	5304456689	A B	Retainer
* #	241709801	A B	Ice Maker, radius cube, 115 V, no instl parts

WIRING DIAGRAM

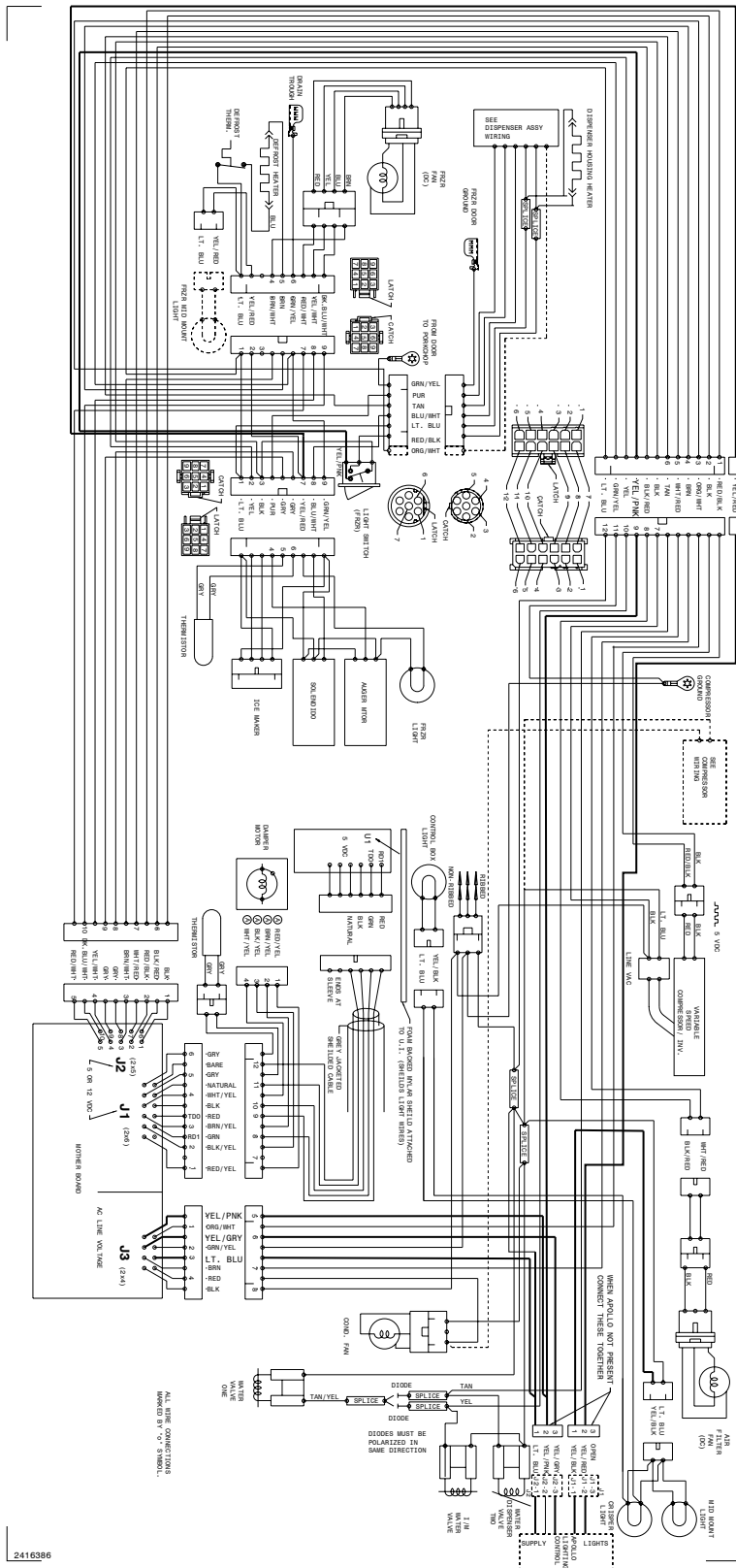

2416396