

Frigidaire

Factory Parts Catalog

Product No.	FEC30S6AB1	FEC30S6AS1	FEC30S6DQ1
Series	30" elec	30" elec	30" elec
Color	black	white	bisque
Market	North America	North America	North America
Wiring Diagram	387621700	387621700	387621700
Owner's Guide	318200612	318200612	318200612
Installation Instructions	318205403	318205403	318205403

 **Electrolux**

Electrolux Major Appliances
North & Latin America
P.O. BOX 212378
AUGUSTA, GA 30917

Publication No.
5995532669
09/02/05
(EN/SERVICE/ECL)
377

**30" ELECTRIC
COOKTOP**

Model No.
FEC30S6A / FEC30S6D

This Publication Supersedes
Publication # 5995532610

Copyright © 2009 Electrolux Home Products, Inc.
All rights reserved.

CONTROL PANEL

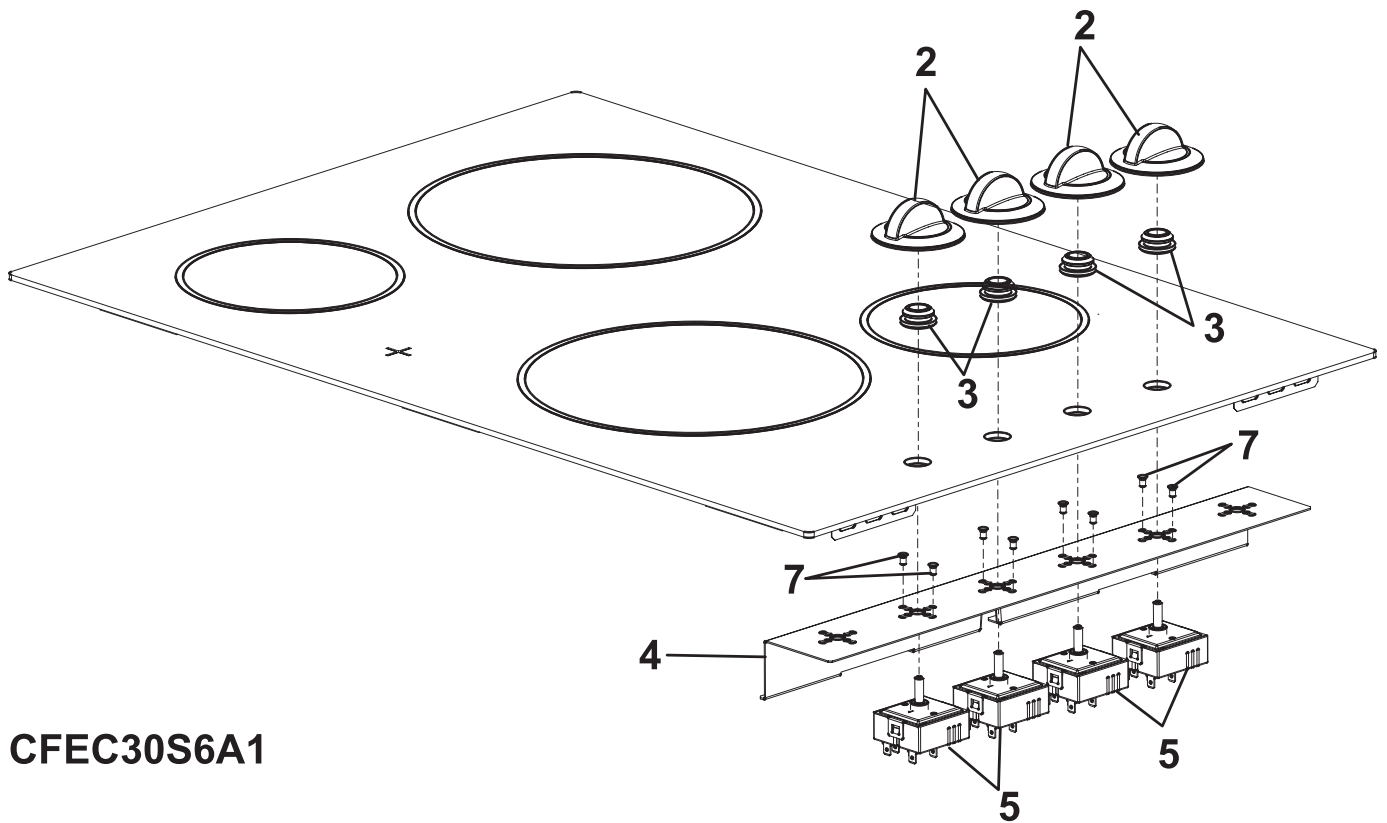

CFEC30S6A1

CONTROL PANEL

Model Index: A FEC30S6A (FEC30S6AB1)
 B FEC30S6A (FEC30S6AS1)
 C FEC30S6D (FEC30S6DQ1)

POS. NO	PART NO.		DESCRIPTION
2	318196634	A - -	Knob, control, black
2	318196633	- B -	Knob, control, white
2	318196635	- - C	Knob, control, bisque
3	387316100	A B C	Bushing, knob, sealing
4	387559700	A B C	Bracket, support, switch mtg.
5 #	305458905	A B C	Switch, surface element
7	319224001	A B C	Screw, switch mtg., M4 x 7

MAIN TOP/SURFACE UNITS

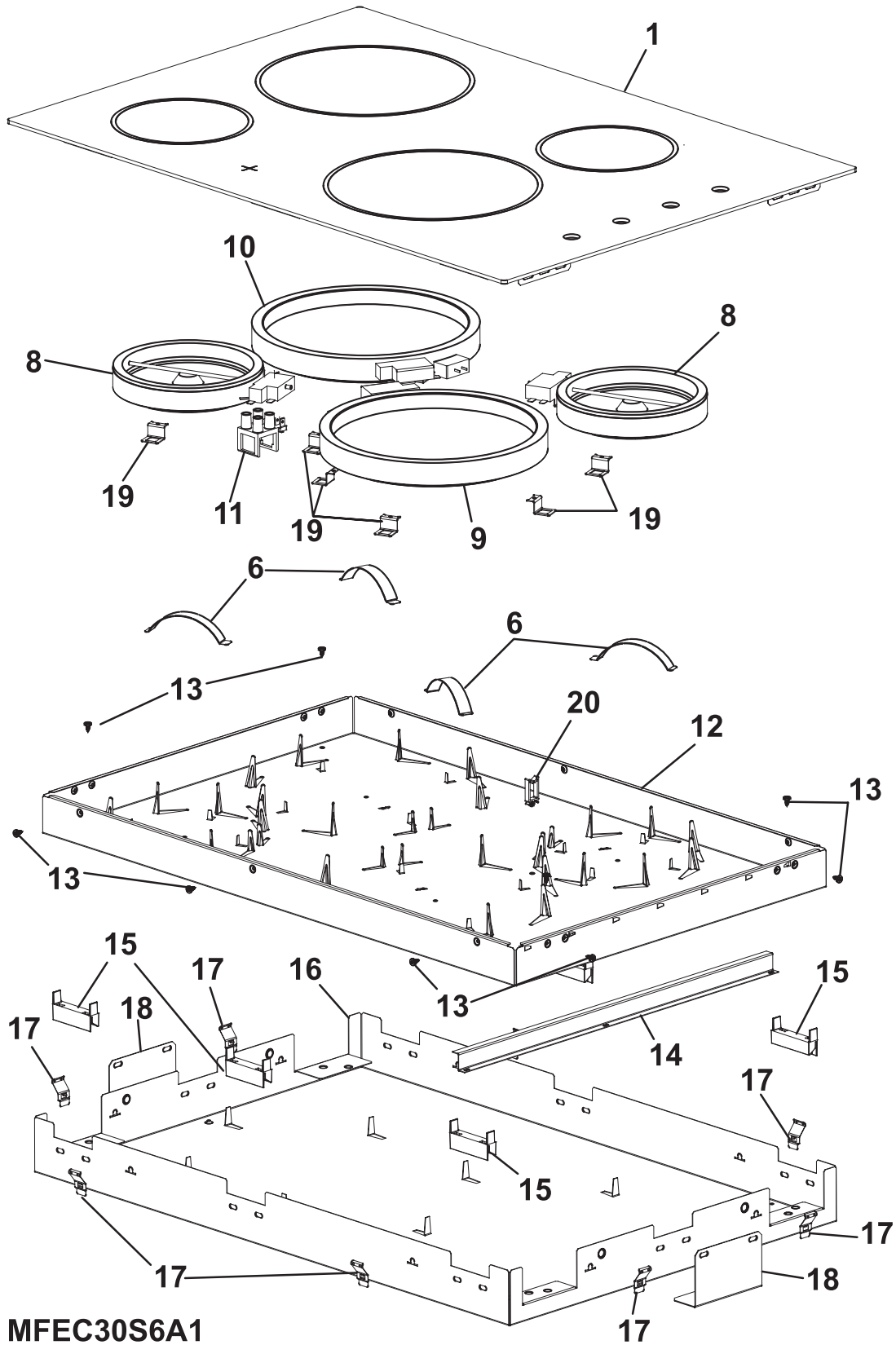

MAIN TOP/SURFACE UNITS

Model Index: A FEC30S6A (FEC30S6AB1)
 B FEC30S6A (FEC30S6AS1)
 C FEC30S6D (FEC30S6DQ1)

POS. NO	PART NO.		DESCRIPTION
1	305379399	A - -	Maintop Assembly, glass, black, w/carrier
1	305379398	- B -	Maintop Assembly, glass, white, w/carrier
1	305379397	- - C	Maintop Assembly, glass, bisque, w/carrier
6	387372900	A B C	Spring, surface element
8 #	374063522	A B C	Element, surface, 6", 1200W
9 #	305440417	A B C	Element, surface, 9", 2500W
10 #	305440416	A B C	Element, surface, 8", 2200W
11 #	387372700	A B C	Light Assembly, indicator, hot surface
12	387558600	A B C	Box, burner, inner
13	330447900	A B C	Screw, B4, 2 x 9, 5
14	387683500	A B C	Support, burner box
*	305351200	A B C	Rivet, 3, 2 x 6
15	387627600	A B C	Spacer, burner box, plastic
16	387559400	A B C	Box, burner, outer
17	387430700	A B C	Bracket, spring, cooktop mtg.
18	387627700	A B C	Bracket, retainer, cooktop
*	305376102	A B C	Screw
*	305309606	A B C	Screw
19	387683300	A B C	Bracket, surface element
*	305376101	A B C	Screw, bracket, surface element
20	387727700	A B C	Retainer, wiring
* #	318078564	A B C	Box & wires assy
* #	387629400	A B C	Harness, wiring, main
*	305452800	A B C	Screw, ground

WIRING DIAGRAM

MODEL WITH BRIDGE ELEMENT / MODELO Y ELEMENTO RADIANTE SUPERIOR DE PUENTE / MODELE AVEC ELEMENT PONT

CODE / CODIGO / STYLE / ESTILO / STYLE CODE

CODE	GAUGE / MEDIDA	TEMP. CALIBRE	cUL	UL
1	16	200°C	UL3122 or UL3135	
2	20	200°C	UL3122 or UL3135	
3	10	150°C	3321	3321
4	12	150°C	3321	3321
5	14	150°C	3321	3321
6	16	150°C	3321	3321

*** NOTE: USE PAGE 2 FOR GAGE AND WIRE COLOR.
 *** NOTA: UTILIZAR LA PAGINA 2 PARA EL CALIBRE Y EL COLOR DE LOS CABLES.
 *** NOTE: UTILISER LA PAGE 2 POUR LE CALIBRE ET LA COULEUR DU FIL.

* LIMITER / LIMITADOR / LIMITEUR CERAMASPEED / EIKA

* LIMITER / LIMITADOR / LIMITEUR E. G. O. / A. K. O.

MODEL WITH DOUBLE ELEMENT / MODELO Y ELEMENTO DE DOBLE / MODELE AVEC ELEMENT DOUBLE

LEGEND 1 / LEYENDA 1 / LEGENDE 1

- SW. - SWITCH INTERRUPTOR INTERRUPTEUR
- P. L. - PILOT LIGHT LAMPARA PILOTO LAMPE TEMOIN
- R. F. - RIGHT FRONT FRENTE DERECHO AVANT DROIT
- R. R. - RIGHT REAR TRASERO DERECHO ARRIERE DROIT
- L. F. - LEFT FRONT FRENTE IZQUIERDO AVANT GAUCHE
- L. R. - LEFT REAR TRASERO IZQUIERDO ARRIERE GAUCHE
- R. C. - REAR CENTER TRASERO CENTRO ARRIERE CENTRE
- L. C. - LEFT CENTER CENTRO DE IZQUIERDO CENTRE GAUCHE
- H. S. - HOT SURFACE SUPERFICIE CALIENTE SURFACE CHAUDE

MODEL WITH REGULAR ELEMENT / MODELO Y ELEMENTO REGULARE / MODELE AVEC ELEMENT REGULIER

LEGEND 2 / LEYENDA 2 / LEGENDE 2

MODEL WITH 4 UNITS / MODELO Y 4 ELEMENTOS / MODELE AVEC 4 ELEMENTS	MODEL WITH 5 UNITS / MODELO Y 5 ELEMENTOS / MODELE AVEC 5 ELEMENTS
BK ON / EN / SUR L. F. POSITION / POSICION / POSITION	BR ON / EN / SUR L. F. POSITION / POSICION / POSITION
W ON / EN / SUR L. R. POSITION / POSICION / POSITION	W ON / EN / SUR L. R. POSITION / POSICION / POSITION
BK ON / EN / SUR R. R. POSITION / POSICION / POSITION	BK ON / EN / SUR R. R. POSITION / POSICION / POSITION
BR ON / EN / SUR R. F. POSITION / POSICION / POSITION	BR ON / EN / SUR R. F. POSITION / POSICION / POSITION

CAUTION: DISCONNECT POWER BEFORE SERVICING UNIT.
ATENCIÓN: DESCONECTE LA ENERGIA ANTES DE REALIZAR EL MANTENIMIENTO DEL ELECTRODOMESTICO.
ATTENTION: COUPER LE COURANT AVANT D'EFFECTUER LA REPARATION.

387 6217 00 REV. B
Page 1

WIRING DIAGRAM

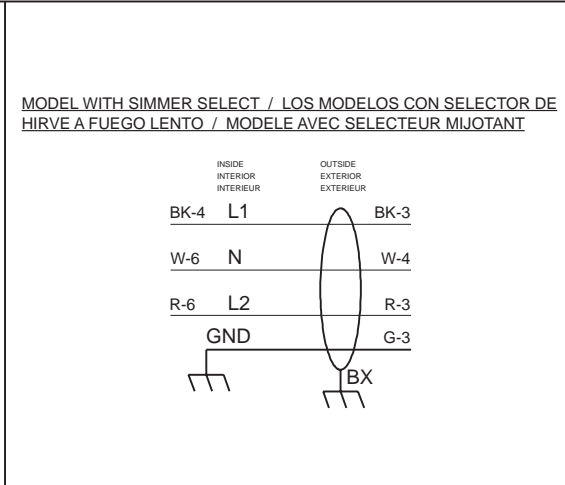
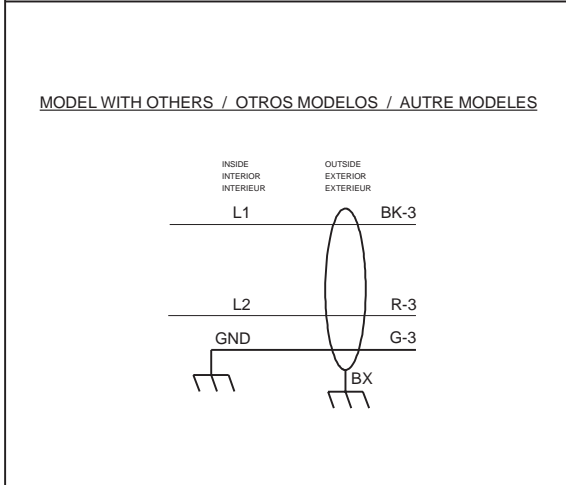
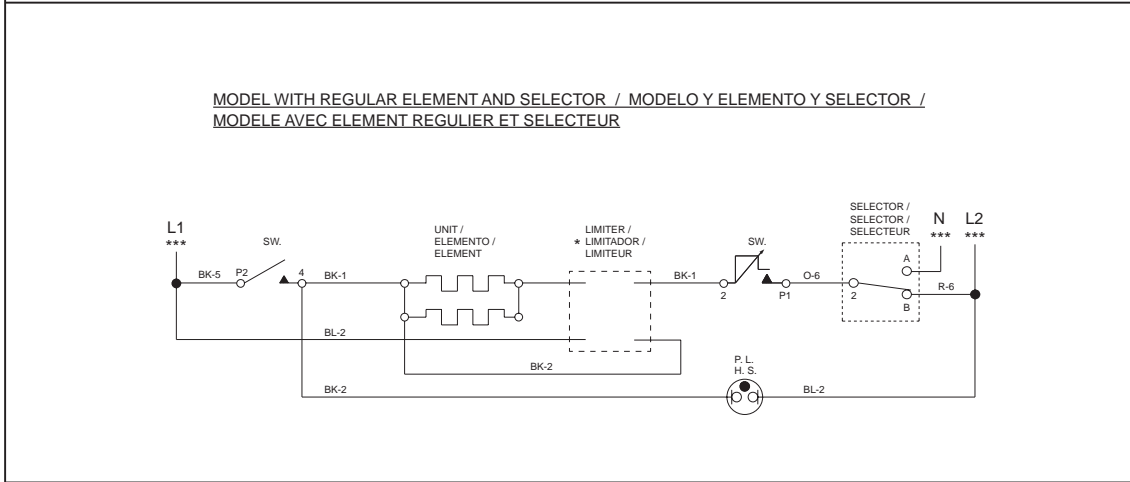
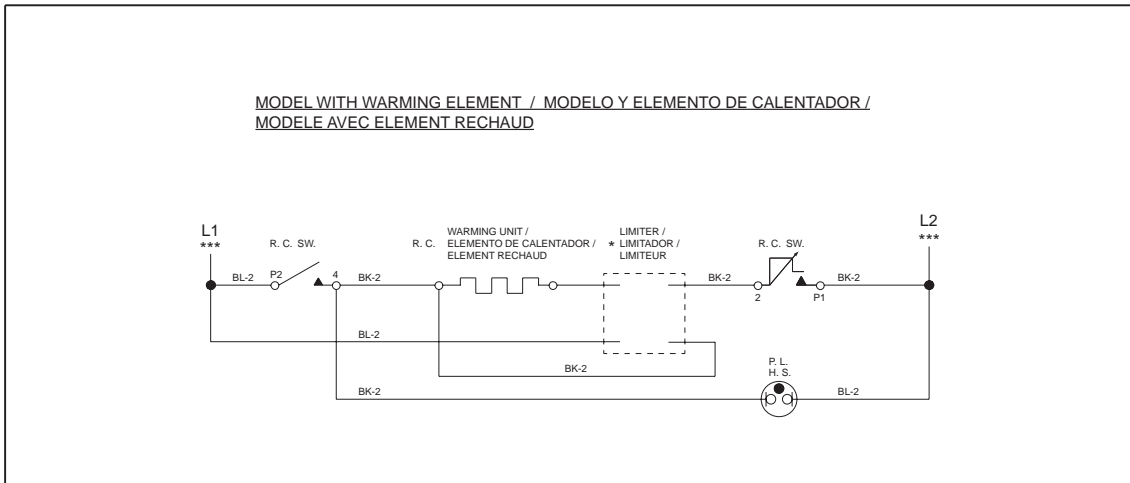

REMARK: FOR CONNECTING THE PLATFORM SEE INSTALLATION SHEET OR USE AND CARE GUIDE.
NOTA: PARA CONECTAR LA PARRILLA DE COCINAR, VER LA HOJA DE INSTALACION O EL MANUAL DEL USUARIO.
REMARQUE: POUR BRANCHER LA TABLE DE CUISSON VOIR LE FEUILLET D'INSTALLATION OU LE MANUEL D'UTILISATION ET D'ENTRETIEN.

CAUTION: DISCONNECT POWER BEFORE SERVICING UNIT.
ATENCIÓN: DESCONECTE LA ENERGIA ANTES DE REALIZAR EL MANTENIMIENTO DEL ELECTRODOMESTICO.
ATTENTION: COUPER LE COURANT AVANT D'EFFECTUER LA REPARATION.

387 6217 00 REV. B
 Page 2