



# FREEZER

## *use & care*

Introduction.....	2	Controls and Settings.....	15
Important Safety information.....	3	Ice Maker .....	19
Features .....	5	Storage Features.....	20
Installation .....	7	Filter Replacement .....	22
Door Removal.....	9	Care and Cleaning .....	23
Door Reversal .....	10	Troubleshooting .....	25
Door Handle Installation.....	11	Limited Warranty .....	28
Water Supply Connection.....	12		

## Welcome to our family

Thank you for bringing Frigidaire into your home! We see your purchase as the beginning of a long relationship together.

This manual is your resource for the use and care of your product. Please read it before using your appliance. Keep it handy for quick reference. If something doesn't seem right, the troubleshooting section will help you with common issues.

FAQs, helpful tips and videos, cleaning products, and kitchen and home accessories are available at [Frigidaire.com](http://Frigidaire.com).

We are here for you! Visit our website, chat with an agent, or call us if you need help. We may be able to help you avoid a service visit. If you do need service, we can get that started for you.

Let's make it official! Be sure to register your product.

Keep your product info here so it's easy to find.

Model Number \_\_\_\_\_  
 Serial Number \_\_\_\_\_  
 Purchase Date \_\_\_\_\_



### Installation Checklist

#### Doors

- Handles are secure and tight
- Door seals completely to cabinet on all sides
- Door is level from side to side across the top

#### Leveling

- Appliance is level, side to side and front to back
- Cabinet is setting solid on all corners
- Anti-tip bracket set in front

#### Electrical Power

- House power turned on
- Appliance plugged in

#### Ice Maker

- House water supply connected to appliance
- No water leaks present at all connections - recheck in 24 hours
- Ice maker is turned on

#### Final Checks

- Shipping material removed
- Registration card sent in



## WARNING

Please read all instructions before using this appliance.

### Safety Definitions

 This is the safety alert symbol. It is used to alert of potential personal injury hazards. Obey all safety messages that follow this symbol to avoid possible injury or death.



## DANGER

DANGER indicates an imminently hazardous situation which, if not avoided, will result in death or serious injury.



## WARNING

WARNING indicates a potentially hazardous situation which, if not avoided, could result in death or serious injury.



## CAUTION

CAUTION indicates a potentially hazardous situation which, if not avoided, may result in minor or moderate injury.



## IMPORTANT

IMPORTANT indicates installation, operation or maintenance information which is important but not hazard-related.



## DANGER



DANGER Risk of fire or explosion. Flammable refrigerant used. Do not use mechanical devices to defrost refrigerator. Do not puncture refrigerant tubing.

DANGER Risk of fire or explosion. Flammable refrigerant used. To be repaired only by trained service personnel. Use only manufacturer-authorized service parts. Any repair equipment used must be designed for flammable refrigerants. Follow all manufacturer repair instructions. Do not puncture refrigerant tubing.



## CAUTION



CAUTION Risk of fire or explosion. Dispose of refrigerator properly in accordance with the applicable federal or local regulations. Flammable refrigerant used.

CAUTION Risk of fire or explosion due to puncture of refrigerant tubing. Follow handling instructions carefully. Flammable refrigerant used.



## WARNING

WARNING! CALIFORNIA RESIDENTS  
Cancer and Reproductive Harm  
[www.P65Warnings.ca.gov](http://www.P65Warnings.ca.gov)

### Child Safety

This appliance is not intended for use by persons (including children) with reduced physical, sensory or mental capabilities, or lack of experience and knowledge, unless they have been given supervision or instruction concerning use of the appliance by a person responsible for their safety.

Destroy or recycle the carton, plastic bags, and any exterior wrapping material immediately after the refrigerator is unpacked. Children should **NEVER** use these items to play. Cartons covered with rugs, bedspreads, plastic sheets or stretch wrap may become airtight chambers, and can quickly cause suffocation.

### Safety Instructions

- DO NOT store or use gasoline, or other flammable liquid within or in the vicinity of this appliance. Read Product Label for warnings regarding flammability and other hazards.
- DO NOT store explosive substances such as aerosol cans with a flammable propellant in this appliance.
- DO NOT operate the refrigerator in the presence of explosive fumes.
- Avoid contact with any moving parts of automatic ice maker.
- Remove all staples from the carton. Staples can cause severe cuts, and also destroy finishes if they come in contact with other appliances or furniture.

### Proper Disposal of your Appliance

#### Risk of child entrapment

Child entrapment and suffocation are not problems of the past. Junked or aban-

# 4

## IMPORTANT SAFETY INFORMATION

doned appliances are still dangerous – even if they will sit for “just a few days”. If you are getting rid of your old appliance, please follow the instructions below to help prevent accidents.

We strongly encourage responsible appliance recycling/disposal methods. Check with your utility company or visit [energystar.gov/products/recycle](http://energystar.gov/products/recycle) for more information on recycling your old appliance.

### Before you throw away your old appliance:

- Remove door.
- Leave shelves in place so children may not easily climb inside.
- Have refrigerant removed by a qualified service technician.



### WARNING

These guidelines must be followed to ensure that safety mechanisms in this appliance will operate properly.

### Electrical information

- Plug the appliance into its own dedicated 115 Volt, 60 Hz., 15 Amp, AC only electrical outlet. The power cord of the appliance is equipped with a 3-prong grounding plug for your protection against electrical shock hazards. Plug it directly into a properly grounded 3-prong receptacle. Install the receptacle in accordance with local codes and ordinances. Consult a qualified electrician. Avoid connecting the appliance to a Ground Fault Interrupter (GFI) circuit. Do not use an extension cord or adapter plug.
- If the power cord is damaged, an authorized service technician should replace it to prevent any risk.
- Never unplug the appliance by pulling on the power cord. Always grip the plug firmly, and pull straight out from the receptacle to prevent damaging the power cord.
- Unplug the appliance before cleaning to avoid electrical shock.
- Performance may be affected if the voltage varies by 10% or more. Operating the appliance with insufficient power can damage the compressor. Such damage is not covered under your warranty.

- Do not plug the unit into an electrical outlet controlled by a wall switch or pull cord to prevent the appliance from being turned off accidentally.
- **WARNING:** Do not use electrical appliances inside the food storage compartments of the appliance unless they are recommended accessories for use within this model.



### IMPORTANT

To turn off power to your appliance you must unplug the power cord from the electrical outlet.

Grounding type wall receptacle

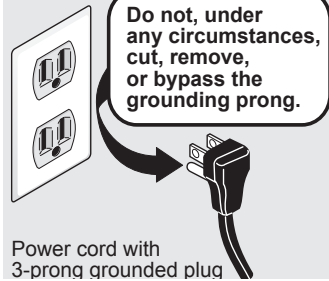

Power cord with 3-prong grounded plug



### IMPORTANT

#### CFC/HCFC Disposal

Your old appliance may have a cooling system that used CFCs or HCFCs (chlorofluorocarbons or hydrochlorofluorocarbons). CFCs and HCFCs are believed to harm stratospheric ozone if released to the atmosphere. Other refrigerants may also cause harm to the environment if released to the atmosphere.

If you are throwing away your old appliance, make sure the refrigerant is removed for proper disposal by a qualified technician. If you intentionally release refrigerant, you may be subject to fines and imprisonment under provisions of environmental legislation.

\*Features may vary according to model

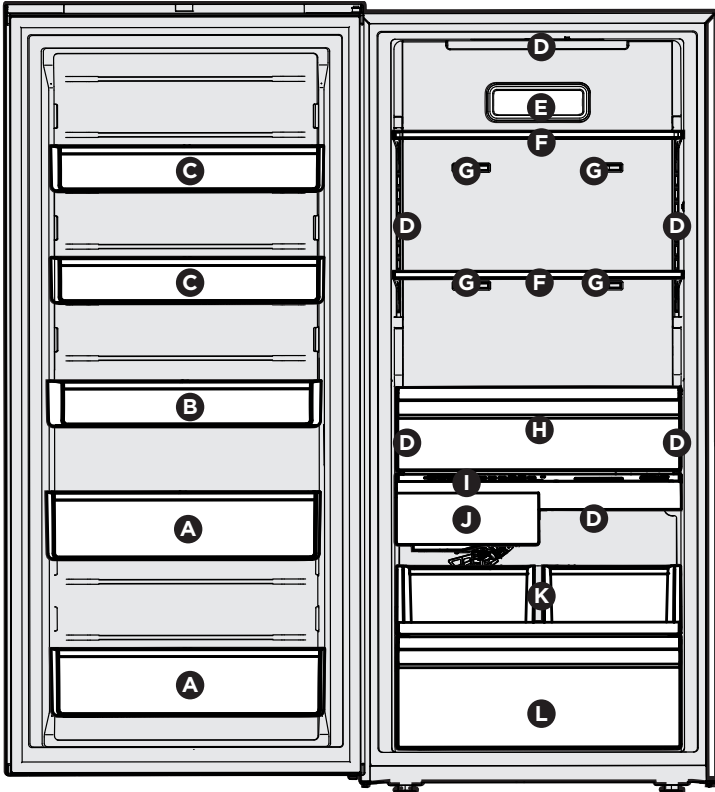

<b>A</b>	Adjustable Tall Item Door Bins with Dividers
<b>B</b>	Adjustable Gallon Door Bin with Divider
<b>C</b>	Adjustable Half-Gallon Door Bins with Dividers
<b>D</b>	LED Lighting
<b>E</b>	Air Filter

<b>F</b>	Adjustable Full Width Metal Shelves
<b>G</b>	*Multi-Port Air Exhaust Ducts
<b>H</b>	Soft Freeze Zone Drawer
<b>I</b>	Appliance Control Display
<b>J</b>	Ice Maker
<b>K</b>	Slide-Out Shelf with Removable Ice Storage Bins
<b>L</b>	Lower Storage Drawer with Dividers

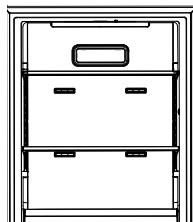

## IMPORTANT

\*Do not place items in front of the Multi-Port Air Exhaust Ducts as this will impact temperature performance.

# 6

## FEATURES

---

### **IMPORTANT**

#### **Cleaning your Appliance**

Remove tape and glue residue from surfaces before turning on the appliance. Rub a small amount of liquid dish soap over any remaining adhesive with your fingers. Rinse with warm water and dry with a soft cloth.

Do not use sharp instruments, rubbing alcohol, flammable fluids, or abrasive cleaners to remove tape or glue. These products can damage the surface of your appliance.

After you remove all of the package materials, clean the inside of your appliance before using it. See the **CARE & CLEANING** section in this manual.

See important information about cleaning glass shelves and covers in the **STORAGE FEATURES** section of this manual.

### **IMPORTANT**

#### **Moving your Appliance**

Your appliance is heavy. When moving the appliance for cleaning or service, raise the anti-tip bracket (see **“Setting the anti-tip bracket”**). Be sure to cover the floor with cardboard or hardboard to avoid floor damage. Always pull the appliance straight out when moving it. Do not wiggle or “walk” the appliance when trying to move it as floor damage could occur.

### **IMPORTANT**

Accessories are available for your appliance and may be purchased at [Frigidaire.com](http://Frigidaire.com) or by calling 1-800-374-4432 (Frigidaire.ca or 1-800-265-8352 in Canada) or from an authorized seller.

---

This Use & Care Guide provides general operating instructions for your model. Use the appliance only as instructed in this Use & Care Guide. Before starting the appliance, follow these important first steps.

## Location

- Choose a place that is near a grounded electrical outlet. Do Not use an extension cord or an adapter plug.
- If possible, place the appliance out of direct sunlight and away from the range, dishwasher or other heat sources.
- Install the appliance on a floor that is level and strong enough to support a fully loaded appliance.



## WARNING

DO NOT install the appliance where the temperature will drop below 0°F (-18°C) or rise above 110°F (43°C). The compressor will not be able to maintain proper temperatures inside the unit.



## CAUTION

Do not block the lower front of your appliance. Sufficient air circulation is essential to operate your appliance properly.

## Installation

### Installation clearances

Allow the following clearances for ease of installation, proper air circulation, and plumbing and electrical connections:

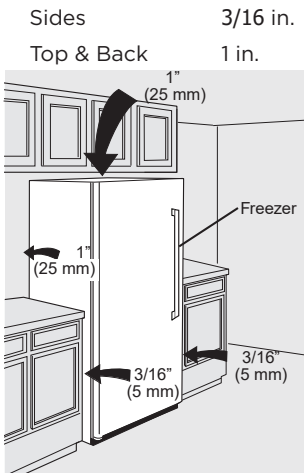

## NOTE

If your appliance is placed with the door hinge side against a wall, you may have to allow additional space for the handle so the door can be opened wider.

## Leveling

Rest all bottom corners firmly on a solid floor.

The floor must be strong enough to support a fully loaded appliance.

It is **VERY IMPORTANT** for your unit to be level in order to function properly. If the appliance is not leveled during installation, the door may be misaligned and not close or seal properly, causing cooling, frost or moisture problems.

### To Level the Appliance:



## CAUTION

The cabinet is heavy. Two people are recommended to level the cabinet.

Level the unit using a carpenter's level. Adjust the leveling feet at the front making minor adjustments to the rear leveling feet as needed. Level the unit front to back and side to side. Make sure all 4 feet fully touch the floor.

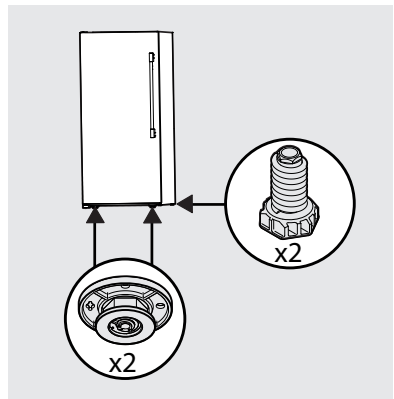

## IMPORTANT

Level the appliance to ensure optimal performance of the ice maker.

# 8

## INSTALLATION

### Setting the anti-tip bracket:

Units are equipped with an anti-tip bracket. The anti-tip bracket is located on the lower front corner of the cabinet, on the lower hinge bracket. After fully leveling the unit, lower the anti-tip foot by turning it clockwise until it securely contacts the floor. Do not raise the cabinet.

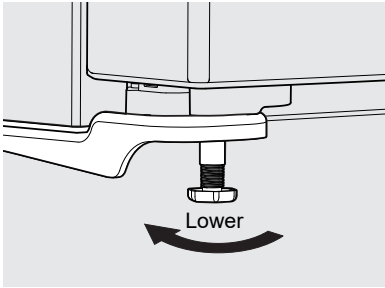

Anti-tip Bracket



### WARNING



The anti-tip device must be installed according to the instructions in your Use & Care Manual. Failure to do so may result in injury.

### Lower Hinge Adjustment for Leveling the Doors of the Matching Refrigerator / Freezer Pair

To level the doors using the adjustable lower hinge (some models):

If the refrigerator door is lower than the freezer door, raise the refrigerator door by turning the adjustment screw counter-clockwise using a 19mm socket wrench. (See illustration below.)

If the freezer door is lower than the refrigerator door, raise the freezer door by turning the adjustment screw counter-clockwise using a 19mm socket wrench. (See illustration below.)

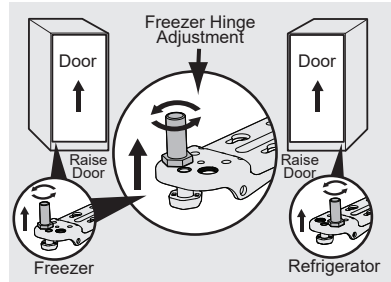

### Guidelines for final positioning of your appliance:

- Rest all bottom leveling feet firmly on a solid floor.
- The cabinet should be level on all sides.
- The door should be level.



## Tools Necessary:

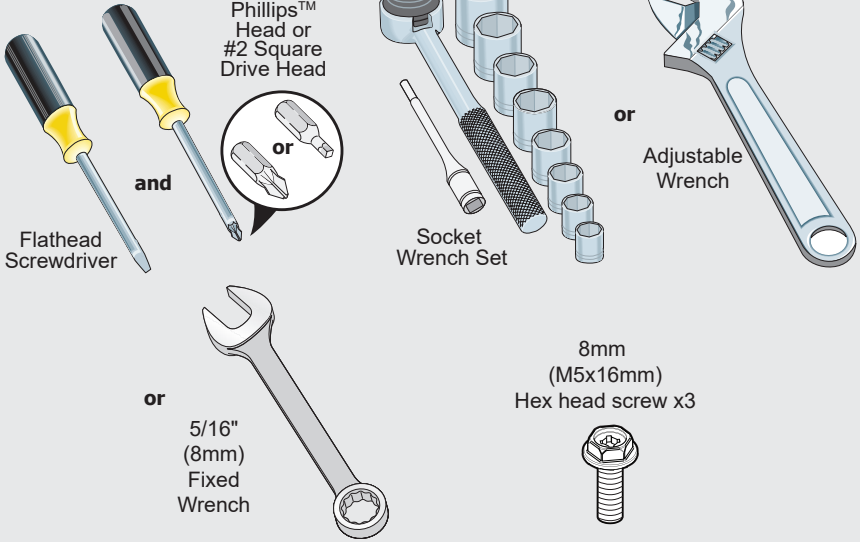

## Door removal:



### IMPORTANT

Before you begin, remove the electrical power cord from the wall outlet. Remove any food from door shelves.



### CAUTION

Doors are heavy. Two people are recommended to remove or replace the door assembly from the cabinet.



### CAUTION

The door should be closed prior to removing or installing

- Unplug the unit or switch the breaker that supplies power to the unit to the off position.
- Remove the plastic top hinge cover.
- Hold the door in place while removing the top hinge from the cabinet.
- Remove the M5x16 mm hex head screws from the top hinge with a wrench or socket.

- Lift the door upwards and pull up and away from the cabinet until free of the bottom hinge pin mounted on the front of the cabinet.
- To replace the door, reverse the above procedures and securely tighten all screws to prevent hinge slippage.

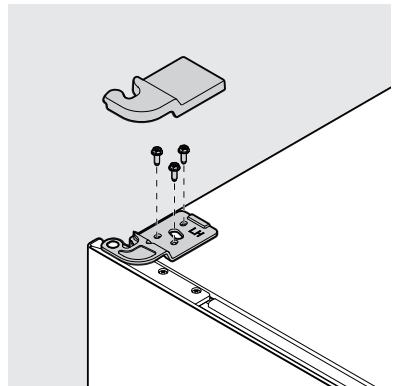

# 10

## DOOR REVERSAL

---

### Door swing reversal:



#### IMPORTANT

A qualified person should change the swing of your door.

If you would like to change your door from a left-hand swing to a right-hand swing, you must purchase a Door Swing Kit.

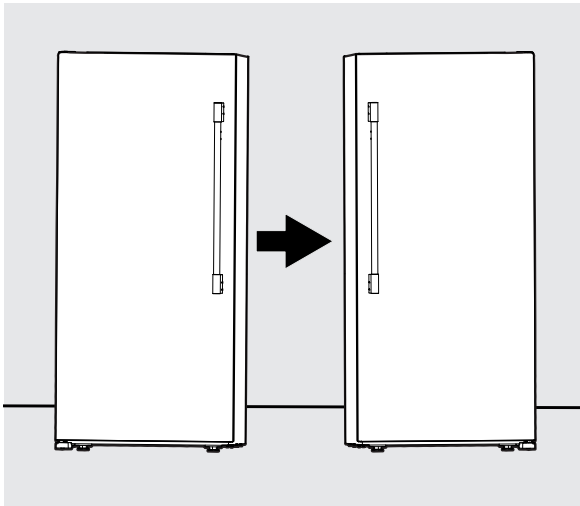

Left-hand Swing

Right-hand Swing



#### CAUTION

Doors are heavy. Two people are recommended to remove or replace the door assembly from the cabinet.

Order Kit TTDRRVFFKIT on [Frigidaire.com](http://Frigidaire.com) or by calling 1-800-374-4432.

---



## CAUTION

Wear gloves and use extreme CAUTION when installing these handles. The rounded end of the handles may be sharp.



## NOTE

All set screws should be tightened and sub-flush (Allen set screw should be seated just below the surface of the end cap) of handle end cap. The end caps should be drawn tight to door with no gaps.

## Door Handle Mounting Instructions

1. Remove handle from carton and any other protective packaging.
2. Position handle end caps over upper and lower pre-installed shoulder bolts (A) that are fastened into door, ensuring the holes for the set screws are facing toward the hinge.
3. While holding handle firmly against door, fasten upper and lower Allen set screws (B) with supplied Allen wrench.

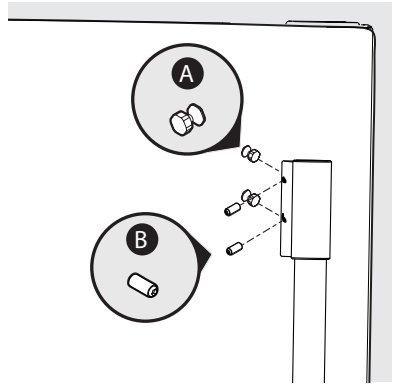

**WARNING**

To avoid electric shock, which can cause death or severe personal injury, disconnect the unit from electrical power source before connecting a water supply line to the appliance.

**CAUTION**

To Avoid Property Damage:

- Use Copper or Stainless Steel braided tubing for the water supply line. Frigidaire does not recommend water supply tubing made of 1/4" plastic. Plastic tubing greatly increases the potential for water leaks, and the manufacturer will not be responsible for any damage if plastic tubing is used for the supply line.
- DO NOT install water supply tubing in areas where temperatures fall below freezing.
- Chemicals from a malfunctioning softener can damage the ice maker. If the ice maker is connected to soft water, ensure that the softener is maintained and working properly.

**NOTE**

Ensure that your water supply line connections comply with all local plumbing codes.

**Before Installing The Water Supply Line, You Will Need:**

- Basic Tools: adjustable wrench, flat-blade screwdriver, and Phillips™ screwdriver
- Access to a household cold water line with water pressure between 30 and 100 psi.
- A braided stainless steel water supply line with integral fittings such as Smart Choice® 5304437642 or 1/4" copper line with compression fittings. The line must be 6' or longer to allow appliance to be moved out for cleaning.
- A shutoff valve to connect the water supply line to your household water system. DO NOT use a self-piercing type shutoff valve.
- Do not reuse compression fitting or use thread seal tape.
- A compression nut and ferrule (sleeve) for connecting a copper water supply line to the ice maker inlet valve.

## To Connect Water Supply Line To Ice Maker Inlet Valve

1. Disconnect the appliance from electrical power source.
2. Place the end of the water supply line into a sink or bucket. Turn ON the water supply and flush the supply line until the water is clear. Turn OFF the water supply at the shutoff valve.
3. Remove the plastic cap from the water valve inlet and discard the cap.
4. If you use **copper tubing** - Slide the brass compression nut, and then the ferrule (sleeve) onto the water supply line. Push the water supply line into the water valve inlet as far as it will go ( $\frac{1}{4}$ "/6.4 mm). Slide the ferrule (sleeve) into the valve inlet and finger tighten the compression nut onto the valve. Tighten another half turn with a wrench; DO NOT overtighten. See Figure 1.

If you use **braided flexible stainless steel tubing** - The nut is already assembled on the tubing. Slide the nut onto the valve inlet and finger tighten the nut onto valve. Tighten another half turn with a wrench; DO NOT overtighten. See Figure 2.

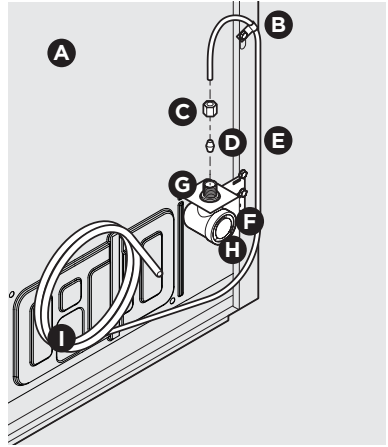

Figure 1

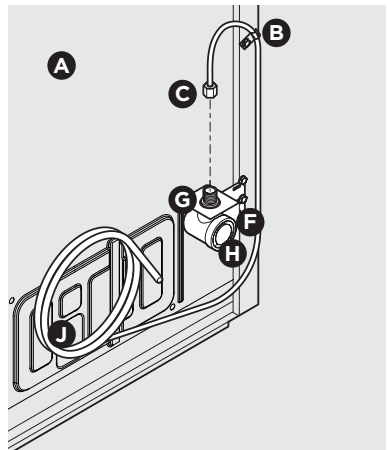

Figure 2

<b>A</b>	Plastic Water Tubing to Ice Maker Fill Tube (foamed within the cabinet)
<b>B</b>	Steel Clamp (Fig. 1: $\frac{1}{4}$ "; Fig. 2: $\frac{1}{2}$ " )
<b>C</b>	Brass Compression Nut
<b>D</b>	Ferrule (Sleeve)
<b>E</b>	Copper Water Line
<b>F</b>	Water Valve Bracket
<b>G</b>	Valve Inlet
<b>H</b>	Water Valve
<b>I</b>	Copper Water Line from Household Water Supply*
<b>J</b>	Braided Flexible Stainless Steel Water Line
*Include enough tubing in the loop to allow moving the appliance out for cleaning	

# 14 WATER SUPPLY CONNECTION

---

5. With the steel clamp and screw, secure the water supply line (copper tubing only) to the rear panel of appliance as shown.
6. Coil the excess water supply line (copper tubing only), about 2½ turns, behind appliance as shown and arrange coils so they do not vibrate or wear against any other surface.
7. Turn ON the water supply at shutoff valve and tighten any connections that leak.
8. Reconnect the appliance to electrical power source.
9. To turn ice maker on, press and hold **ICE MAKER** on the appliance display for 3 seconds.

## NOTE

Check with your local building authority for recommendations on water lines and associated materials prior to installing your new appliance. Depending on your local/state building codes, Frigidaire recommends for homes with existing valves its Smart Choice® water line kit 5305513409 (with a 6' Stainless Steel Water Line) and for homes without an existing valve, Frigidaire recommends its Smart Choice® water line kit 5305510264 (with a 20' copper water line with self-tapping saddle valve). Please refer to [Frigidaire.com](http://Frigidaire.com) for more information.

## Cool Down Period

To ensure safe food storage, allow the appliance to operate with the door closed for at least 8 hours before loading it with food.

## Power On

Upon opening the door, the settings icon will illuminate on the control panel.



By pressing the settings icon, you will illuminate all of the icons on the appliance control. After 10 seconds of no user interaction with the icons or door closure, all the icons will fade, except for the settings icon.

## Appliance Control Display

The appliance control display is located in the cabinet below the upper drawer.

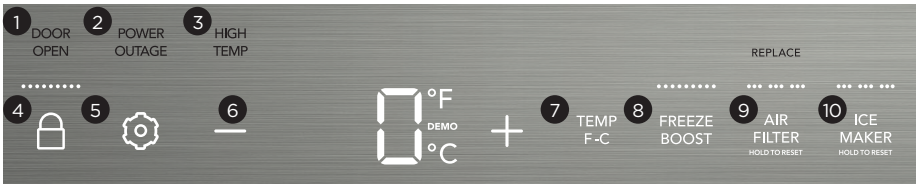
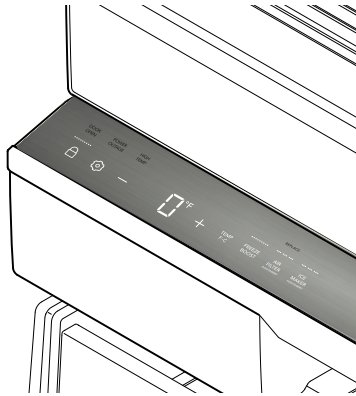

# 16



## CONTROLS AND SETTINGS

---

### Alarms

- 1 DOOR OPEN**  
This alert indicates the door has been open for 5 minutes or more. The **DOOR OPEN** LED will illuminate and the audible alert will sound until the door is closed.  
The audible alert can be turned off by pressing **DOOR OPEN** or by closing the door. If the door is ajar for 5 minutes, the interior light will turn off.
- 2 POWER OUTAGE**  
The **POWER OUTAGE** indicator light informs you there has been a power interruption which could have led to the internal temperature increasing beyond the safe temperature range. After you check your food, reset the alarm by pressing **POWER OUTAGE**.
- 3 HIGH TEMP**  
If the temperature increases above a safe temperature range, the red **HIGH TEMP** LED light will illuminate and the alarm will sound. Reset the alarm by pressing **HIGH TEMP**.

### Controls

- 4** The lock button can be used to lock the control panel. Press and hold  for 3 seconds to enable/disable. While in the locked state, no changes can be made until unlocked.
  - 5** The settings icon illuminates upon opening the appliance door. Press  to reveal other function icons. After 10 seconds of non use of icons or door closure, all icons will fade except .
  - 6 Adjusting Temp**  
To adjust the temperature setting, press **+** to raise the temperature and **-** to lower the temperature on the appliance control. Allow several hours for the temperature to stabilize between adjustments.
  - 7 TEMP °F/°C**  
Short press to toggle between Fahrenheit (°F) and Celsius (°C).
  - 8 FREEZE BOOST**  
Prior to grocery shopping, activate **FREEZE BOOST** so upon returning you can ensure your newly purchased frozen food will be preserved.  
Turning on **FREEZE BOOST** will cool the appliance down to a target temperature and will remain active for up to 24 hours before automatically deactivating or being manually exited.  
To turn the function off, press **FREEZE BOOST**. When you turn off **FREEZE BOOST**, it will automatically reset the freezer back to the previous temperature setting.
  - 9 AIR FILTER**  
The **AIR FILTER** replacement alert will illuminate when it is time to replace the air filter. See the **FILTER REPLACEMENT** section for instructions on how to replace the air filter. After changing the air filter, reset the **AIR FILTER** alert by pressing and holding **AIR FILTER**.
  - 10 ICE MAKER**  
The ice maker is default on, which means it will constantly make ice until the ice bucket is full. The ice maker can be turned off to stop making new ice. Press and hold **ICE MAKER** for 3 seconds to turn it on/off.
-



## Sabbath Mode

The Sabbath Mode is a feature that disables portions of the appliance and its controls in accordance with observance of the weekly Sabbath and religious holidays within the Orthodox Jewish community.

### To enter Sabbath Mode

Simultaneously press and hold **—** and **TEMP F/C** for 5 seconds.

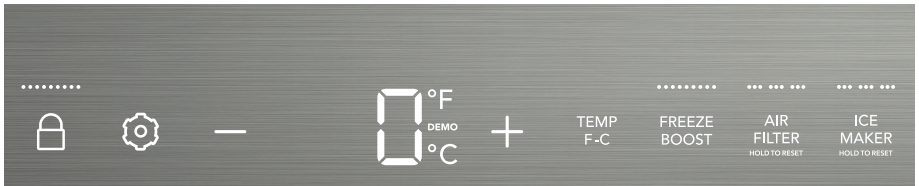

“Sb” will appear on the appliance control display indicating the unit is in Sabbath mode.



For further assistance, guidelines of proper usage and a complete list of models with the Sabbath feature, please visit the web at [star-k.org](http://star-k.org).

The unit stays in Sabbath mode after a power failure recovery. It must be deactivated with the buttons on the appliance control display.



### NOTE

While in Sabbath Mode, neither the lights nor the appliance control display will work (except to exit Sabbath Mode) until Sabbath Mode is deactivated.

Additionally, the ice maker will stop ice production when Sabbath mode is activated.

The appliance stays in Sabbath Mode after power failure recovery. It must be deactivated with the buttons on the appliance control display.

# 18 CONTROLS AND SETTINGS

---

## To exit Sabbath Mode

Simultaneously press and hold **—** and **TEMP F/C** for 5 seconds.



The appliance control display will show all of the icons.

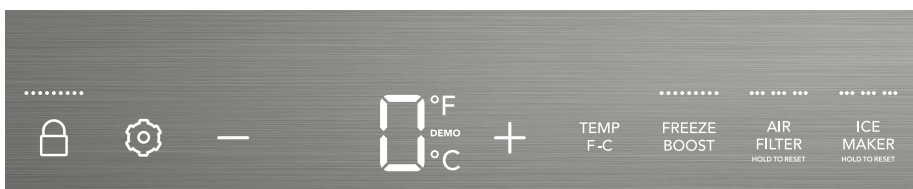

In the Sabbath mode, the **HIGH TEMP** alarm is active for health reasons. For example, if you leave the door ajar, the **HIGH TEMP** alarm is activated. The freezer will function normally once you close the door, without any violation of the Sabbath/holidays. The **HIGH TEMP** alarm comes on when the cabinet temperature is outside the safe zone for 20 minutes. The alarm silences itself after 10 minutes while the **HIGH TEMP** icon stays lit until you exit the Sabbath mode.

All buttons are disabled, and all sounds (except the **HIGH TEMP** alert\* and the combination to exit Sabbath Mode) are muted. Only the **HIGH TEMP** alert will illuminate until you deactivate the Sabbath Mode.



Your appliance has an automatic ice maker that will provide a sufficient supply of ice for normal use. The unit will not produce ice during the first 24 hours of initial operation.

### Turning Your Ice Maker On

After you have completed connecting the plumbing, you must open the water supply valve. To turn the ice maker on, press  on the appliance control display. Then press and hold **ICE MAKER** until the LEDs above **ICE MAKER** are illuminated. New plumbing connections may cause the first production of ice cubes to be discolored or have an odd flavor. Discard these first cubes until the cubes produced are free of discoloration and taste.

### Turning Your Ice Maker Off

To turn the ice maker off, press  on the appliance control display. Then press and hold **ICE MAKER** until the LEDs above **ICE MAKER** are turned off. Separately, the ice maker automatically stops producing ice when the bin is full, and then restarts when the level of ice drops. Note that when the ice maker is turned Off at the appliance control, the ice maker will not produce ice at all.

### Ice Maker Tips

- If the ice maker will be turned off for a long period of time, turn the water supply valve to the closed position.
- Ice cubes stored too long may develop an odd flavor. Empty the ice bin. The ice maker will then produce more ice.
- Occasionally shake the ice container to keep ice separated.
- Keep the ice maker off until the ice maker is connected to the water supply or whenever the water supply is turned off.
- The following sounds are normal when the ice maker is operating:
  - Motor running
  - Ice loosening from tray
  - Ice dropping into ice container
  - Running water
  - Water valve opening or closing



#### IMPORTANT

To ensure proper function of your ice maker, hook up the water supply immediately or turn the ice maker off (see **ICE MAKER** in **CONTROLS AND SETTINGS**).



#### CAUTION

- DO NOT place the ice bin in the dishwasher.
- Wash the ice bin in warm water with mild detergent. Rinse well and dry.
- Turn off the ice maker when cleaning the freezer and during vacations.

### Ice Maker Storage Bin

#### Capacity

The ice maker should produce about 4.5 lbs of ice per 24 hours, depending on conditions of use.

#### How much ice can be stored in the ice bins?

When completely full, the bins will hold about 8 lbs of ice.

**IMPORTANT**

When placing frozen items in the freezer, leave a gap of at least 2" at the top of the freezer. Stacking items to the top can cause ice buildup.

**Full Width Cantilever Shelves**

Multi-position adjustable metal shelves can be moved to any position for larger or smaller packages. The shipping spacers that stabilize the shelves for shipping may be removed and discarded.

**To Adjust The Shelves**

- Remove all food from the shelf.
- Lift the front edge up to release the tabs from the slots in the rear and pull the shelf out.
- Replace the shelf by inserting the mounting bracket hooks into the desired support slots at the rear.
- Carefully lower the shelf and lock into position.

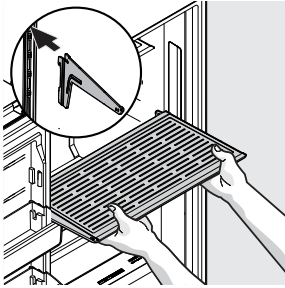
**Soft Freeze Zone**

The soft freeze zone drawer remains slightly warmer than the freezer interior for convenient storage of soft freeze items such as ice cream.

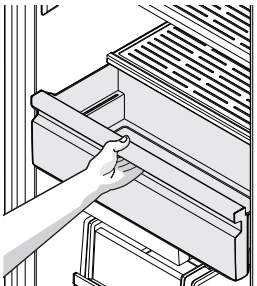
**Slide-Out Shelf with Removable Ice Storage Bins**

The slide-out shelf provides easy access to the removable ice storage bin. You should return it back to its fully closed position to allow the ice maker to properly dispense ice cubes. If the slide-out shelf is not in its fully closed position, it will cause ice to be dispensed outside the ice bin, possibly causing the need for a service call.

The removable storage bins hold ice from the ice maker. The left-hand bin is in the primary location for holding dispensed ice. If you prefer more ice, simply move the bin to the right, and put the other bin in place on the left-hand side for holding newly dispensed ice. When not holding ice, the right-hand bin can be used for additional storage. Or you can remove the right-hand bin in order to use the slide-out shelf for storage.

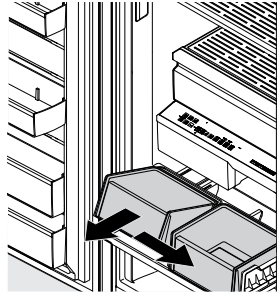
**Lower Drawer with Dividers**

The lower drawer with dividers works great for food that may need to be separated. The drawer can easily be used with the dividers or without by removing or adding the inserts.

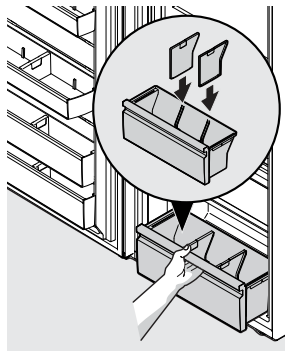

### Door Bin Dividers

Customize your unit to fit different sized items as your needs change with door bin dividers.

**To remove**, grasp the divider and pull it upward until it disengages with the door bin.

**To install**, slide the divider downward into the corresponding door bin alignment features until it is fully placed.

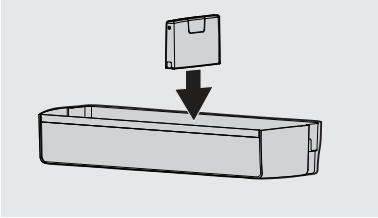

### Adjustable Door Bins

The adjustable door bins are specially designed to hold large containers or storage bags. Each bin type can be used only in the zone indicated below so the door can close correctly. Your unit has 2 Half-Gallon Door Bins (Zone A), a Gallon Door Bin (Zone B), and 2 Tall Item Door Bins (Zone C).

#### To remove a door bin:

- Grasp the ends of the door bin.
- Lift the door bin up until it clears the locking lugs.
- Pull the door bin straight out toward you.

#### To install a door bin:

- Make sure the locking feature on the bin aligns with the mounting lugs on the door.
- Lower the door bin into the mounting lugs until it locks in place.

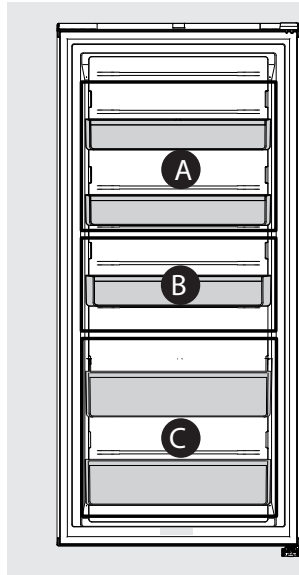

# 22 FILTER REPLACEMENT

## PureAir Ultra II™ Air Filter

With more power to clear the air, Frigidaire air filters banish pungent smells and work better than baking soda. *PureAir Ultra II™* Air Filters:

- **More powerful than baking soda**  
Keep your unit fresh for up to 6 months.
- **Captures & Keeps Odors Away**  
Absorbs undesirable smells with carbon technology.

Here are the product numbers to request when ordering:

*PureAir Ultra II™* Air Filter  
**PAULTRA2™**

### Installing or replacing the air filter

Your new *PureAir Ultra II™* air filter is located in the air filter cover, located in the top center of the cabinet.

Your appliance control display is equipped with a **REPLACE AIR FILTER** indicator to remind you to change your filter every 6 months to ensure optimal filtering of appliance odors. To order your replacement filters, please visit our online store at [Frigidaire.com](http://Frigidaire.com), by calling toll-free at 1 (800) 372-4432, or by visiting the dealer where you purchased your unit.

The air filter element is held in by the removable air filter cover which has a stainless steel decorative plate.

1. Grab the cover with your hand, pulling until it releases from the fixed air filter housing. The air filter element is mounted on the back of the cover.
2. Remove the old filter and discard it.
3. Unpackage the new filter and snap it into the filter cover. The open face (carbon media) of the filter should be installed facing outward in the cover.
4. Reattach the air filter cover to the air filter housing by aligning the cover to the housing and firmly pushing it until it snaps in place.
5. Press and hold **REPLACE AIR FILTER** on the appliance control to reset it.

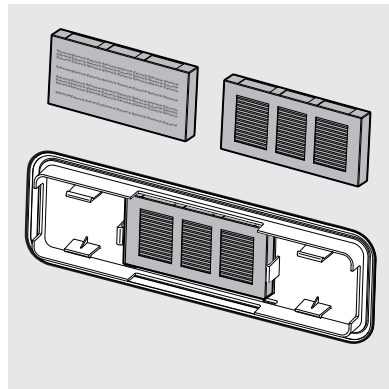
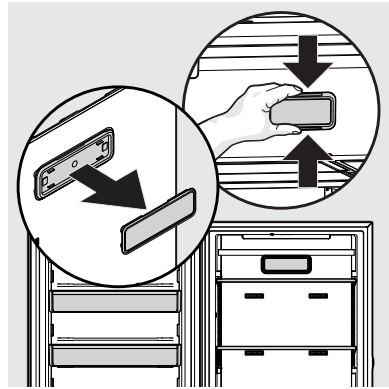

## Protecting your investment

Keeping your appliance clean maintains appearance and prevents odor build-up. Wipe up any spills immediately and clean the appliance at least twice a year. When cleaning, take the following precautions:

- Never use CHLORIDE or cleaners with bleach to clean stainless steel.
- Do not wash any removable parts in a dishwasher.
- Always unplug the electrical power cord from the wall outlet before cleaning.
- Remove adhesive labels by hand. Do not use razor blades or other sharp instruments which can scratch the appliance surface.
- Do not remove the serial plate.

Do not use abrasive cleaners such as window sprays, scouring cleansers, brushes, flammable fluids, cleaning waxes, concentrated detergents, bleaches or cleansers containing petroleum products on plastic parts, interior doors, gaskets or cabinet liners. Do not use paper towels, metallic scouring pads, or other abrasive cleaning materials or strong alkaline solutions.



### CAUTION

Damp objects stick to cold metal surfaces. Do not touch interior metal surfaces with wet or damp hands.



### CAUTION

When moving the unit, pull straight out. Do not shift the appliance from side to side as this may tear or gouge the floor covering.

## Vacation and Moving Tips

**Short Vacations:** Leave the unit operating during vacations of less than 3 weeks.

**Long Vacations:** If the appliance will not be used for several months:

- Remove all food and unplug the power cord.
- Clean and dry the interior thoroughly.
- Leave the door open slightly, blocking it open if necessary, to prevent odor and mold growth.

**Moving:** When moving the unit, follow these guidelines to prevent damage:

- Disconnect the power cord plug from the wall outlet.
- Remove foods, then defrost, and clean the appliance.
- Secure all loose items such as base panel, baskets, and shelves by taping them securely in place to prevent damage.
- In the moving vehicle, secure unit in an upright position to prevent movement. Also protect outside of the appliance with a blanket, or similar item.



### NOTE

- To disconnect electrical power to the lights or other electrical components, unplug the unit or switch the breaker that supplies power to the unit to the off position.
- Do not use razor blades or other sharp instruments which can scratch the appliance surface when removing adhesive labels. Any glue left from tape or labels can be removed with a mixture of warm water and mild detergent, or, touch the glue residue with the sticky side of tape you have already removed. Do not remove the serial plate.

# 24 CARE AND CLEANING

---

Care & Cleaning Tips		
Part	What To Use	Tips and Precautions
Interior & Door Liners	<ul style="list-style-type: none"><li>• Soap and water</li><li>• Baking soda and water</li></ul>	Use 2 tbsp of baking soda in 1 qt of warm water. Be sure to wring excess water out of sponge or cloth before cleaning around controls, light bulb or any electrical part.
Door Gaskets	<ul style="list-style-type: none"><li>• Soap and water</li></ul>	Wipe gaskets with a clean soft cloth.
Drawers & Bins	<ul style="list-style-type: none"><li>• Soap and water</li></ul>	Use a soft cloth to clean drawer runners and tracks. Do not wash any removable items (bins, drawers, etc.) in dishwasher.
Exterior & Handles	<ul style="list-style-type: none"><li>• Soap and water</li><li>• Non-Abrasive Glass Cleaner</li></ul>	Do not use commercial household cleaners, ammonia, or alcohol to clean handles. Use a soft cloth to clean smooth handles. Do not use a dry cloth to clean smooth doors.
Metal Shelves	<ul style="list-style-type: none"><li>• Soap and water</li></ul>	Clean with a soft cloth
Door & Stainless Steel Air Tower Cover	<ul style="list-style-type: none"><li>• Soap and water</li><li>• Stainless steel cleaners</li></ul>	Clean with non-abrasive, soapy water and a dishcloth. Rinse with clean water and a soft cloth. Use a non-abrasive stainless steel cleaner. These cleaners can be purchased at most home improvement or major department stores. Always follow manufacturer's instructions. Do not use household cleaners containing ammonia or bleach. <b>NOTE:</b> Always clean, wipe and dry with grain to prevent scratching.



Let us help you troubleshoot your concern! This section will help you with common issues. If you need us, visit our website, chat with an agent, or call us. We may be able to help you avoid a service visit. If you do need service, we can get that started for you!

**1-800-374-4432 (United States)**

**1-800-265-8352 (Canada)**

**Frigidaire.com**

**Frigidaire.ca**

CONCERN	CAUSE	SOLUTION
<b>APPLIANCE OPERATION</b>		
<b>Appliance does not run.</b>	<ul style="list-style-type: none"> <li>• Appliance is plugged into a tripped Ground Fault Interrupt (GFI).</li> <li>• Appliance may not be plugged in or plug is loose.</li> <li>• House fuse blown or tripped circuit breaker.</li> <li>• Power outage.</li> </ul>	<ul style="list-style-type: none"> <li>• Appliance must be plugged into a dedicated circuit with standard outlet. Contact a certified electrician to check.</li> <li>• Ensure plug is tightly pushed into outlet.</li> <li>• Check/replace fuse with a 15-amp time-delay fuse. Reset circuit breaker.</li> <li>• Check house lights. Call the local electric company.</li> </ul>
<b>Appliance temperature is colder than preferred.</b>	<ul style="list-style-type: none"> <li>• The freezer temperature is set too low.</li> </ul>	<ul style="list-style-type: none"> <li>• Check freezer temperatures and adjust the temperature control as needed.</li> </ul>
<b>Appliance temperature is warmer than preferred.</b>	<ul style="list-style-type: none"> <li>• The freezer temperature is set too high.</li> <li>• The door is ajar.</li> </ul>	<ul style="list-style-type: none"> <li>• Set control to a colder setting until appliance temperature is satisfactory. Allow 24 hours for the temperature to stabilize.</li> <li>• Make sure the door is completely closed and sealed.</li> </ul>
<b>Appliance is noisy or vibrates.</b>	<ul style="list-style-type: none"> <li>• The cabinet is not level.</li> <li>• Floor is weak.</li> </ul>	<ul style="list-style-type: none"> <li>• Adjust the leveling feet. See “<b>Leveling</b>” in the <b>INSTALLATION</b> section.</li> </ul>
<b>Appliance runs too much or too long.</b>	<ul style="list-style-type: none"> <li>• Room or outside weather is hot.</li> <li>• Appliance has recently been disconnected for a period of time.</li> <li>• Large amounts of warm or hot food have been stored recently.</li> <li>• Door is opened too frequently or too long.</li> <li>• Door may be slightly open.</li> <li>• Temperature control is set too low.</li> <li>• Gaskets are dirty, worn, cracked, or poorly fitted.</li> </ul>	<ul style="list-style-type: none"> <li>• It’s normal for the appliance to work longer under these conditions.</li> <li>• It may take 24 hours for the appliance to cool down completely.</li> <li>• Warm food will cause appliance to run more until the desired temperature is reached.</li> <li>• Warm air entering the appliance causes it to run more. Open door less often.</li> <li>• See <b>DOOR PROBLEMS</b> in <b>TROUBLESHOOTING</b> section.</li> <li>• Turn control knob to a warmer setting. Allow several hours for the temperature to stabilize.</li> <li>• Clean or change gasket. (See <b>Care and Cleaning Tips</b> in <b>CARE AND CLEANING</b> section). Worn, cracked or poorly fitting gaskets should be replaced.</li> </ul>

# 26 TROUBLESHOOTING

CONCERN	CAUSE	SOLUTION
<b>APPLIANCE TEMPERATURES</b>		
<b>Interior appliance temperature is too cold.</b>	<ul style="list-style-type: none"> <li>• Temperature control is set too low.</li> </ul>	<ul style="list-style-type: none"> <li>• Set control to a warmer setting. Allow several hours for temperature to stabilize.</li> </ul>
<b>Temperature inside appliance is too warm.</b>	<ul style="list-style-type: none"> <li>• Temperature control is set too warm.</li> <li>• Door is opened too frequently or too long.</li> <li>• Door may not be seating properly.</li> <li>• Large amount of warm or hot food has been stored recently.</li> <li>• Unit has recently been disconnected for a period of time.</li> </ul>	<ul style="list-style-type: none"> <li>• Turn control to a colder setting. Allow several hours for temperature to stabilize.</li> <li>• Warm air enters the appliance every time the door is opened. Open door less often.</li> <li>• Look for food items on the shelves or in the door bins keeping the door from closing completely.</li> <li>• Wait until the appliance has had a chance to reach its selected temperature.</li> <li>• Appliance may take up to 24 hours to cool down completely.</li> </ul>
<b>🔒 is displayed on control.</b>	<ul style="list-style-type: none"> <li>• The control has been locked.</li> </ul>	<ul style="list-style-type: none"> <li>• Press 🔒 for 3 seconds to unlock.</li> </ul>
<b>“Sb” is displayed on the control.</b>	<ul style="list-style-type: none"> <li>• The control is in Sabbath Mode.</li> </ul>	<ul style="list-style-type: none"> <li>• Press — and <b>TEMP F/C</b> for 5 seconds.</li> </ul>
<b>AUTOMATIC ICE MAKER</b>		
<b>Ice maker is not making any ice.</b>	<ul style="list-style-type: none"> <li>• Ice maker is turned off.</li> </ul>	<ul style="list-style-type: none"> <li>• Turn on the ice maker. Press and hold the “On/Off” button for 3 seconds until the indicator light is on.</li> </ul>
<b>Ice maker is not making enough ice.</b>	<ul style="list-style-type: none"> <li>• Freezer control is set too warm.</li> </ul>	<ul style="list-style-type: none"> <li>• Set freezer control to a colder setting to improve performance of the ice maker. Allow 24 hour for temperature to stabilize.</li> </ul>
<b>Ice cubes are freezing together.</b>	<ul style="list-style-type: none"> <li>• Ice cubes are not being used frequently enough.</li> <li>• Ice cubes are hollow (partially frozen cubes with water inside).</li> <li>• Freezer control is set too warm.</li> </ul>	<ul style="list-style-type: none"> <li>• Remove ice container and discard ice from the container. The ice maker will produce fresh ice.</li> <li>• Ice and water filter cartridge may be clogged. Replace filter cartridge.</li> <li>• Set the freezer control to a colder setting. Allow 24 hours for temperature to stabilize.</li> </ul>
<b>SOUND AND NOISE</b>		
<b>Louder sound levels whenever appliance is on.</b>	<ul style="list-style-type: none"> <li>• Modern freezers have increased storage capacity and more stable temperatures. They require heavy-duty compressors.</li> </ul>	<ul style="list-style-type: none"> <li>• This is normal. When the surrounding noise level is low, you might hear the compressor running while it cools the interior.</li> </ul>
<b>Popping or cracking sound when compressor comes on. Bubbling or gurgling sound.</b>	<ul style="list-style-type: none"> <li>• Metal parts undergo expansion and contraction, as in hot water pipes.</li> <li>• Refrigerant (used to cool the freezer) is circulating throughout the system.</li> </ul>	<ul style="list-style-type: none"> <li>• This is normal. Sound will level off or disappear as appliance continues to run.</li> <li>• This is normal.</li> </ul>

<b>CONCERN</b>	<b>CAUSE</b>	<b>SOLUTION</b>
<b>Vibrating or rattling noise.</b>	<ul style="list-style-type: none"> <li>• Appliance is not level. It rocks on the floor when it is moved slightly.</li> <li>• Floor is uneven or weak.</li> <li>• Appliance is touching the wall.</li> </ul>	<ul style="list-style-type: none"> <li>• Level the appliance. Refer to “Leveling” in the <b>INSTALLATION</b> section.</li> <li>• Ensure floor can adequately support the appliance. Level the appliance by putting wood or metal shims under part of the appliance.</li> <li>• Re-level appliance or move appliance slightly. Refer to “Leveling” in the <b>INSTALLATION</b> section.</li> </ul>
<b>WATER / MOISTURE / FROST INSIDE APPLIANCE</b>		
<b>Moisture forms on inside appliance walls.</b>	<ul style="list-style-type: none"> <li>• Weather is hot and humid, which increases internal rate of frost buildup.</li> <li>• Door is slightly open.</li> <li>• Door is kept open too long.</li> </ul>	<ul style="list-style-type: none"> <li>• This is normal.</li> <li>• Look for food items on the shelves or in the door bins keeping the door from closing completely.</li> <li>• Open the door less often.</li> </ul>
<b>ODOR IN APPLIANCE</b>		
<b>Odors in appliance.</b>	<ul style="list-style-type: none"> <li>• Interior needs to be cleaned.</li> <li>• Foods with strong odors are in the appliance.</li> </ul>	<ul style="list-style-type: none"> <li>• Clean interior with sponge, warm water, and baking soda. Replace air filter.</li> <li>• Cover the food tightly.</li> </ul>
<b>DOOR PROBLEMS</b>		
<b>Door will not close.</b>	<ul style="list-style-type: none"> <li>• Appliance is not level. It rocks on the floor when it is moved slightly.</li> <li>• Floor is uneven or weak.</li> </ul>	<ul style="list-style-type: none"> <li>• This condition can force the cabinet out of square and misalign the door. Refer to “Leveling” in the <b>INSTALLATION</b> section.</li> <li>• Ensure floor can adequately support appliance. Level the appliance by putting wood or metal shims under part of the appliance.</li> <li>• Look for food items on the shelves or in the door bins keeping the door from closing completely.</li> </ul>
<b>LIGHTING PROBLEMS</b>		
<b>Cabinet light is not working.</b>	<ul style="list-style-type: none"> <li>• LED is burned out.</li> </ul>	<ul style="list-style-type: none"> <li>• Call a Frigidaire service technician.</li> </ul>

Your appliance is covered by a one year limited warranty. For one year from your original date of purchase, Electrolux will pay all costs for repairing or replacing any parts of this appliance that prove to be defective in materials or workmanship when such appliance is installed, used and maintained in accordance with the provided instructions.

#### Exclusions

##### This warranty does not cover the following:

1. Products with original serial numbers that have been removed, altered or cannot be readily determined.
2. Product that has been transferred from its original owner to another party or removed outside the USA or Canada.
3. Rust on the interior or exterior of the unit.
4. Products purchased "as-is" are not covered by this warranty.
5. Food loss due to any Appliance or freezer failures.
6. Products used in a commercial setting.
7. Service calls which do not involve malfunction or defects in materials or workmanship, or for appliances not in ordinary household use or used other than in accordance with the provided instructions.
8. Service calls to correct the installation of your appliance or to instruct you how to use your appliance.
9. Expenses for making the appliance accessible for servicing, such as removal of trim, cupboards, shelves, etc., which are not a part of the appliance when it is shipped from the factory.
10. Service calls to repair or replace appliance light bulbs, air filters, water filters, other consumables, or knobs, handles, or other cosmetic parts.
11. Surcharges including, but not limited to, any after hour, weekend, or holiday service calls, tolls, ferry trip charges, or mileage expense for service calls to remote areas, including the state of Alaska.
12. Damages to the finish of appliance or home incurred during installation, including but not limited to floors, cabinets, walls, etc.
13. Damages caused by: services performed by unauthorized service companies; use of parts other than genuine Electrolux parts or parts obtained from persons other than authorized service companies; or external causes such as abuse, misuse, inadequate power supply, accidents, fires, or acts of God.

#### DISCLAIMER OF IMPLIED WARRANTIES; LIMITATION OF REMEDIES

CUSTOMER'S SOLE AND EXCLUSIVE REMEDY UNDER THIS LIMITED WARRANTY SHALL BE PRODUCT REPAIR OR REPLACEMENT AS PROVIDED HEREIN. CLAIMS BASED ON IMPLIED WARRANTIES, INCLUDING WARRANTIES OF MERCHANTABILITY OR FITNESS FOR A PARTICULAR PURPOSE, ARE LIMITED TO ONE YEAR OR THE SHORTEST PERIOD ALLOWED BY LAW, BUT NOT LESS THAN ONE YEAR. ELECTROLUX SHALL NOT BE LIABLE FOR CONSEQUENTIAL OR INCIDENTAL DAMAGES SUCH AS PROPERTY DAMAGE AND INCIDENTAL EXPENSES RESULTING FROM ANY BREACH OF THIS WRITTEN LIMITED WARRANTY OR ANY IMPLIED WARRANTY. SOME STATES AND PROVINCES DO NOT ALLOW THE EXCLUSION OR LIMITATION OF INCIDENTAL OR CONSEQUENTIAL DAMAGES, OR LIMITATIONS ON THE DURATION OF IMPLIED WARRANTIES, SO THESE LIMITATIONS OR EXCLUSIONS MAY NOT APPLY TO YOU. THIS WRITTEN WARRANTY GIVES YOU SPECIFIC LEGAL RIGHTS. YOU MAY ALSO HAVE OTHER RIGHTS THAT VARY FROM STATE TO STATE.

#### If You Need Service

Keep your receipt, delivery slip, or some other appropriate payment record to establish the warranty period should service be required. If service is performed, it is in your best interest to obtain and keep all receipts. Service under this warranty must be obtained by contacting Electrolux at the addresses or phone numbers below.

This warranty only applies in the USA and Canada. In the USA, your appliance is warranted by Electrolux Major Appliances North America, a division of Electrolux Home Products, Inc. In Canada, your appliance is warranted by Electrolux Canada Corp. Electrolux authorizes no person to change or add to any obligations under this warranty. Obligations for service and parts under this warranty must be performed by Electrolux or an authorized service company. Product features or specifications as described or illustrated are subject to change without notice.

**USA**  
**1-800-374-4432**  
 Frigidaire  
 10200 David Taylor Drive  
 Charlotte, NC 28262



**Electrolux**

**Canada**  
**1.800.265.8352**  
 Electrolux Canada Corp.  
 5855 Terry Fox Way  
 Mississauga, Ontario, Canada  
 L5V 3E4

# FRIGIDAIRE®

welcome *home*

Our home is your home. Visit us if you need help with any of these things:



owner support



accessories



service



registration

(See your registration card for more information.)

Frigidaire.com  
1-800-374-4432

Frigidaire.ca  
1-800-265-8352