

24" BUILT-IN COFFEE MACHINE



CODE ID

MATTEO COFFEE MACHINE - MATTE BLACK

F7MBC24MB1



LED Lighting



Cappuccino/Latte Maker



On-demand Hot Water



Bean Hopper - Adjustable Grinder

PERFORMANCE

Espresso / Double Espresso
Coffee / Double Coffee
Latte
Cappuccino
Milk froth
Warm milk
Hot water
Water heating time: 1 minute
Automatic rinsing cycle

FEATURES

3 temperature settings
5 coffee strength settings:
extra-strong, strong, medium,
mild, extra-mild
5 cup size settings: espresso,
small, medium, large, mug
Cappuccino
Steam
Hot water
Stand-by (energy saving)

MAINTENANCE

Water hardness setting
Coffee and water refill indicators
Empty waste container indicator
Cleaning indicator
Descale indicator

INCLUDED ACCESSORIES

Container for milk
Telescopic rails
Power cord with plug

24" BUILT-IN COFFEE MACHINE

MATTEO COFFEE MACHINE

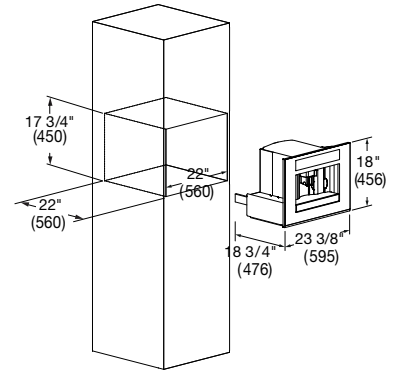

| F7MBC24MB1 | |
|--|--------------------------|
| Type | Coffee machine |
| Finish | Matte Black |
| FEATURES | |
| Total number of modes | 30 |
| Automatic modes | Coffee, Steam, Hot water |
| User Interface | Full touch electronic |
| Water tank capacity | 60 fl. oz |
| Bean hopper capacity | 7 oz |
| Adjustable grinder with 13 settings | • |
| Cups of coffee dispensed at a time | 1 or 2 |
| Maximum cup height 3.93 in / 100 mm | • |
| Dispenser for steam and hot water | • |
| LED lighting | • |
| Automatic system rinsing | • |
| Auto wakeup | • |
| Auto shutoff | • |
| Milk container 25 fl.oz - 740 ml | • |
| Drip tray | • |
| Fill Water Tank warning on the display (Water tank only - cannot be plumbed in) | • |
| ELECTRICAL SPECIFICATION (120V, 60 HZ) | |
| Max rated power (W) | 1350 W |
| Pump pressure (bar) | 15 |
| SIZE | |
| Overall dim - width | 23 3/8" (595mm) |
| Overall dim - height | 18" (456mm) |
| Overall dim - depth | 18 3/4" (476mm) |
| Cutout - width | 22" (560mm) |
| Cutout - height (min) | 17 3/4" (450mm) |
| Cutout - depth (min) | 22" (560mm) |
| INSTRUCTION FOR USE | |
| Use & Care Manual / Installation Manual | EN, SP, FR |