

FULGOR MILANO

30" Induction Ranges Top 600 SERIES

Weight & Dimensions

PRODUCT DIMENSIONS

30" Wide Rangetop Models

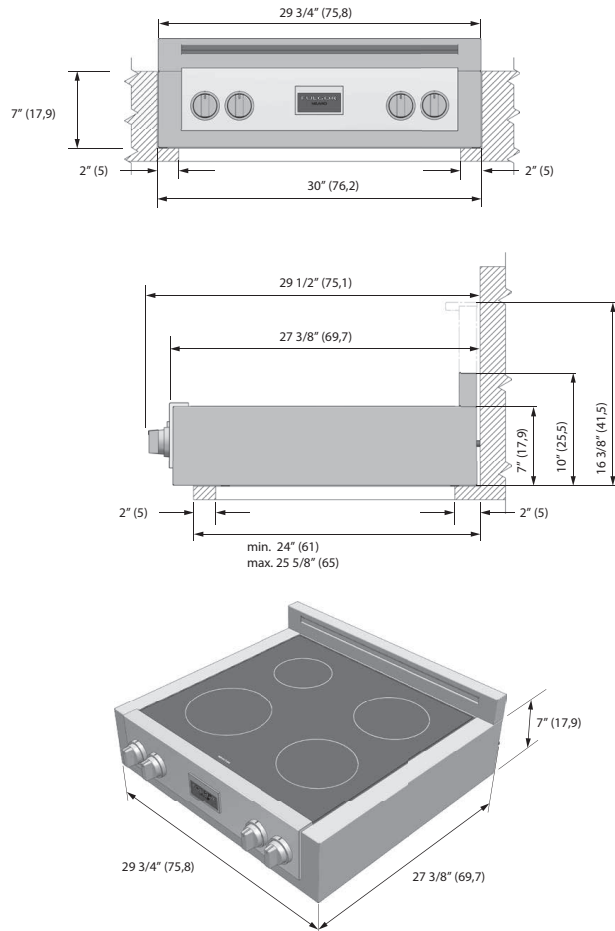

CUTOUT REQUIREMENTS

The surface of the entire back wall above the range and below the hood must be covered with a noncombustible material.

*Consult local code for exact location requirements.

Note: Clearances to non-combustible materials must conform with local codes or, in the absence of local codes, with the National Fuel Gas Code, ANSI Z223.1/NFPA 54.

ADDITIONAL CLEARANCES:

For island installation, maintain 2-1/2 in. minimum from cutout to back edge of countertop and 3 in. minimum from cutout to side edges of countertop (see top view).

Minimum clearances:

Above cooking surface (above 36" [91.4 cm])

- Sides 3" (7.6 cm)

Within 3" (7.6 cm) side clearance, wall cabinets no deeper than 13" (33.0 cm) must be minimum 18" (45.7 cm) above cooking surface.

Wall cabinets directly above product must be a minimum of 30" (76.2 cm) above cooking surface.

Rear - 0" with 3" (7.6 cm) backguard.

FLUSH ISLAND INSTALLATION

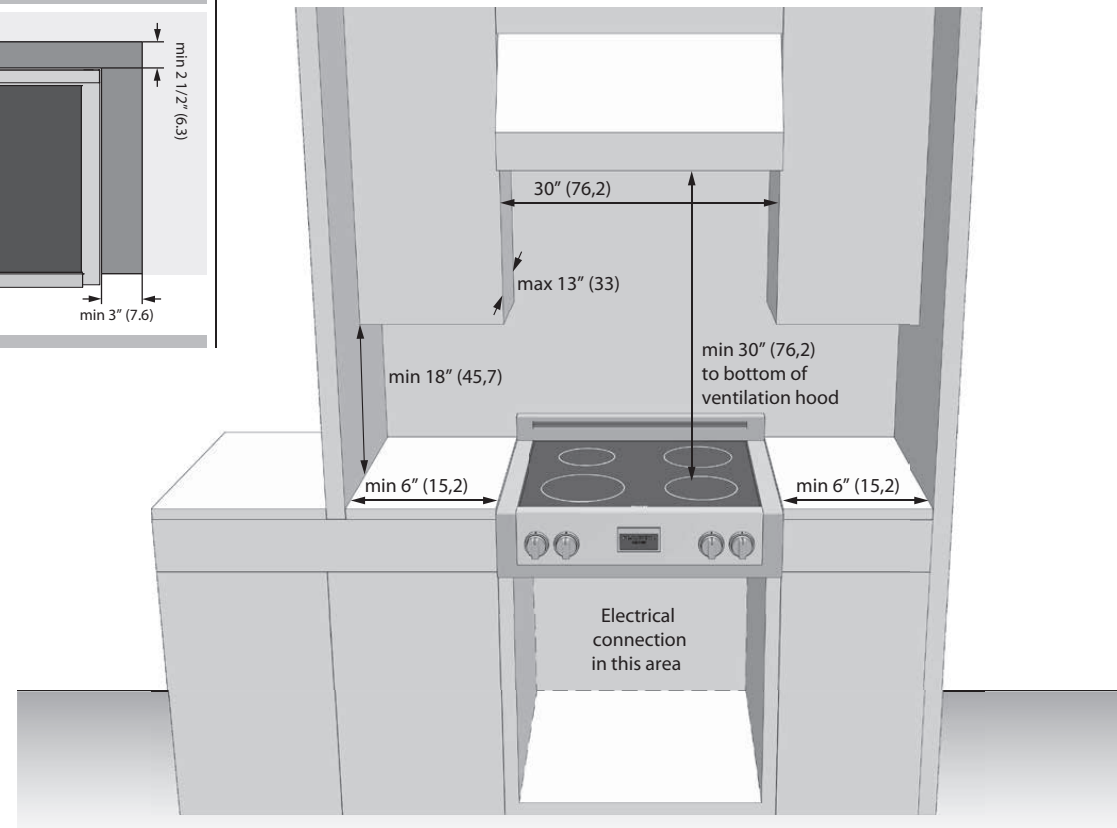
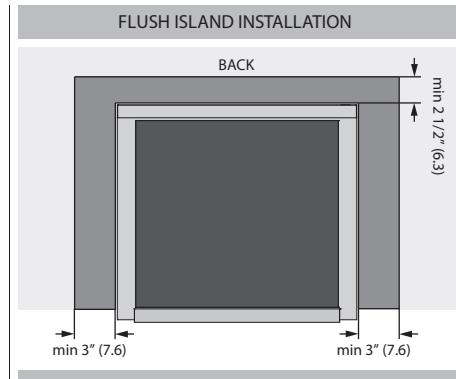

PACKAGING 30"		lb / inch	Kg / mm
GROSS WEIGHT		71 lb	32 Kg
DIMENSION	W	38"3/4	984
	D	32"1/8	817
	H	13"3/8	340

INSTALLATION WITH SEPARATOR SHEET

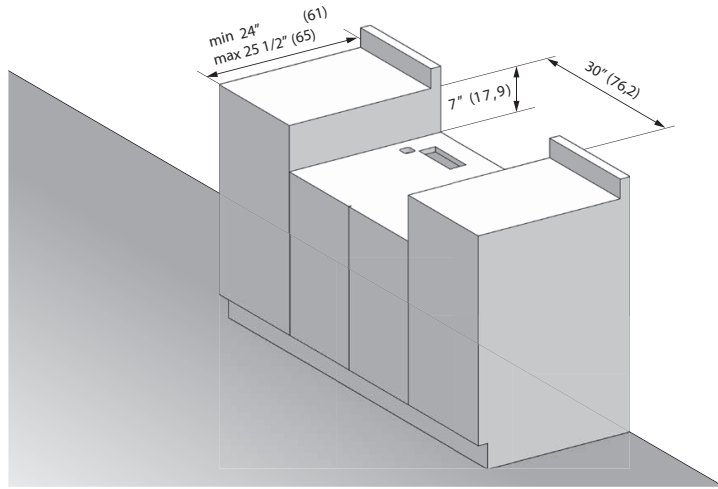

INSTALLATION WITHOUT SEPARATOR SHEET

