

# Monogram wall ovens







## Simply professional

For years, designers have stressed the importance of simplicity in design and life. The new Monogram® wall oven collection embraces this ideal and takes it to elegant new heights.





**Electronic dials** combine the precision of modern digital technology with the simplicity of turn-to-set controls.



**Exclusive self-clean, full-extension oven racks** glide in and out on stainless-steel ball bearings for easy access. The adjustable, heavy-duty, porcelain-coated racks can remain in the oven during the self-clean cycle.



**Six electronically controlled heating elements**—two bake, two broil and two convection—provide substantially reduced preheat times and precision cooking control. Reverse-Air convection technology utilizes a bidirectional fan, and ensures even heat distribution for ideal results.

## Simply elegant

Advanced technology and a host of thoughtful features transform everyday cooking tasks into simple joys.



## Gallery of modern design

### Monogram® integrated wall ovens

Electronic dial controls are as elegant as they are ergonomic.

Sleek tubular handles are smooth, rugged and easy to grasp.

Hand-finished edges reflect the meticulous quality and craftsmanship for which Monogram products are renowned.

Large viewing window allows you to view your culinary work in progress.

Standard GE dimensions match the industry's preferred cutout sizes for remarkably simple installation.



**ZET1SLSS** Integrated single wall oven



**ZET2SLSS** Integrated double wall oven

### Monogram professional wall ovens

Electronic dial controls have a robust, die-cast metal design, yet rotate with smooth digital precision.

Professional-style handles are solid and substantial, reinforcing the overall look of sculptural sophistication.

Chamfered, hand-finished edges give the premium-grade stainless steel door an added sense of depth and dimension.

Large viewing window allows you to view your culinary work in progress.

Standard GE dimensions match the industry's preferred cutout sizes for remarkably simple installation.



**ZET1PLSS** Professional single wall oven



**ZET2PLSS** Professional double wall oven

Exclusive self-clean, full-extension oven racks glide in and out smoothly on stainless steel ball bearings, and are designed to be left in the oven during the self-clean cycle.

Halogen light columns on the oven walls provide brilliant task lighting for each rack position.

4.4-cu.-ft. total capacity easily accommodates even the largest meals.

True hidden bake elements are concealed beneath the oven floor, allowing easy ash removal after the self-clean cycle.



Reverse-Air convection system uses dedicated heating elements and bidirectional fan to provide consistent temperature throughout the oven.

Six-element design—two bake, two broil and two convection—provides precise cooking control, with fast preheating.

208V performance compensation utilizes the six-element design to boost power in reduced-voltage installations.

Two broil elements with reflector shield offer intense, dual-zone broiling.



## Simply better

Always elevating the bar for appliance innovation, Monogram® ovens offer design and performance possibilities unmatched by any other brand. It's a difference consumers can see in their kitchens and appreciate in their cooking.

APPEARANCE



**Monogram.** Two 304 stainless steel designs offer two outstanding appearance choices. Integrated models have a smooth exterior with a tubular handle. The professional ovens make a bold statement with raised chamfered edges, die-cast metal dials and a professional handle to match the appearance of Monogram's professional line of products.

**Wolf.** Rotating control panel design does not coordinate with their professional cooktop line.

**Fisher & Paykel.** Ovens are available only in an integrated design.

CONTROLS



**Monogram.** Electronic dials combine the precision of digital technology with the simplicity of a traditional dial. The die-cast or stainless steel dials turn with the ease of a stereo tuner dial, rotating smoothly in either direction.

**Wolf.** All models include electronic touch controls only.

**Viking.** Standard electromechanical dials offer simplicity, but do not deliver the control, accuracy and performance of digital technology.

CONVECTION SYSTEM



**Monogram.** Reverse-Air convection technology promotes even heat circulation with dual convection elements and a bidirectional fan, eliminating the need to rotate trays midway through the cooking process.

**Viking, Bosch, Fisher & Paykel and others.** Offer only traditional single-direction convection performance.



HEATING ELEMENTS



**Monogram.** The only brand to offer six heating elements—two bake, two broil and two convection—for fast preheating and precise cooking control. Multiple heating elements and advanced electronics allow quick preheating in 208-volt applications.

**Wolf and Viking.** Single heating elements do not offer the same performance and preheating speed.

INTERIOR LIGHTING



**Monogram.** Six halogen lights create illuminated columns on both sides of the oven to enhance visibility on each rack position.

**Wolf.** Wolf offers staggered single lighting on each side wall with no illuminated columns of light.

**Fisher and Paykel.** Staggered single side lighting provides less than half the amount of light throughout the oven.

CAPACITY



**Monogram.** Oven interior offers a generous 4.4-cubic-foot capacity, easily accommodating even the largest meals.

**Fisher & Paykel.** Oven interior offers 10 percent less capacity, with only 4.0 cubic feet of space.

**Viking.** Small, 3.3-cu.-ft. design can make it difficult to orchestrate meals when entertaining.

OVEN RACKS



**Monogram.** The best of both worlds. Adjustable, heavy-duty porcelain-coated oven racks are not only full-extension, but they can also remain in the oven during the self-clean cycle.

**Fisher & Paykel, Wolf, Viking and other brands.** Standard chrome racks do not self-clean and most do not fully extend.

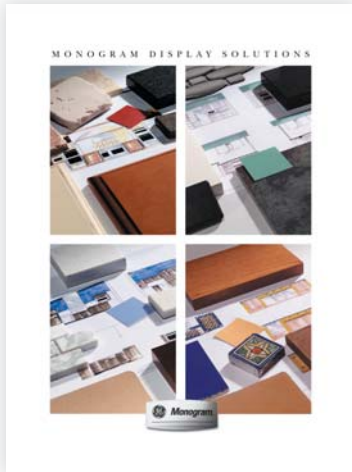

## A display of simplicity

Monogram has made realizing dreams simple, allowing you to capture the full attention of consumers and increase sales without the services of a designer.

**Monogram Display Solutions** makes your life as simple as possible. This collection of fine concepts for displaying Monogram® products has all the preplanning taken care of, from the design to the hardware and even the countertop selections. The result is a complete design package that will save you precious hours while developing a highly professional display to sell more Monogram appliances.

For a complete selection of showroom design solutions, order publication number 24-M413.\*

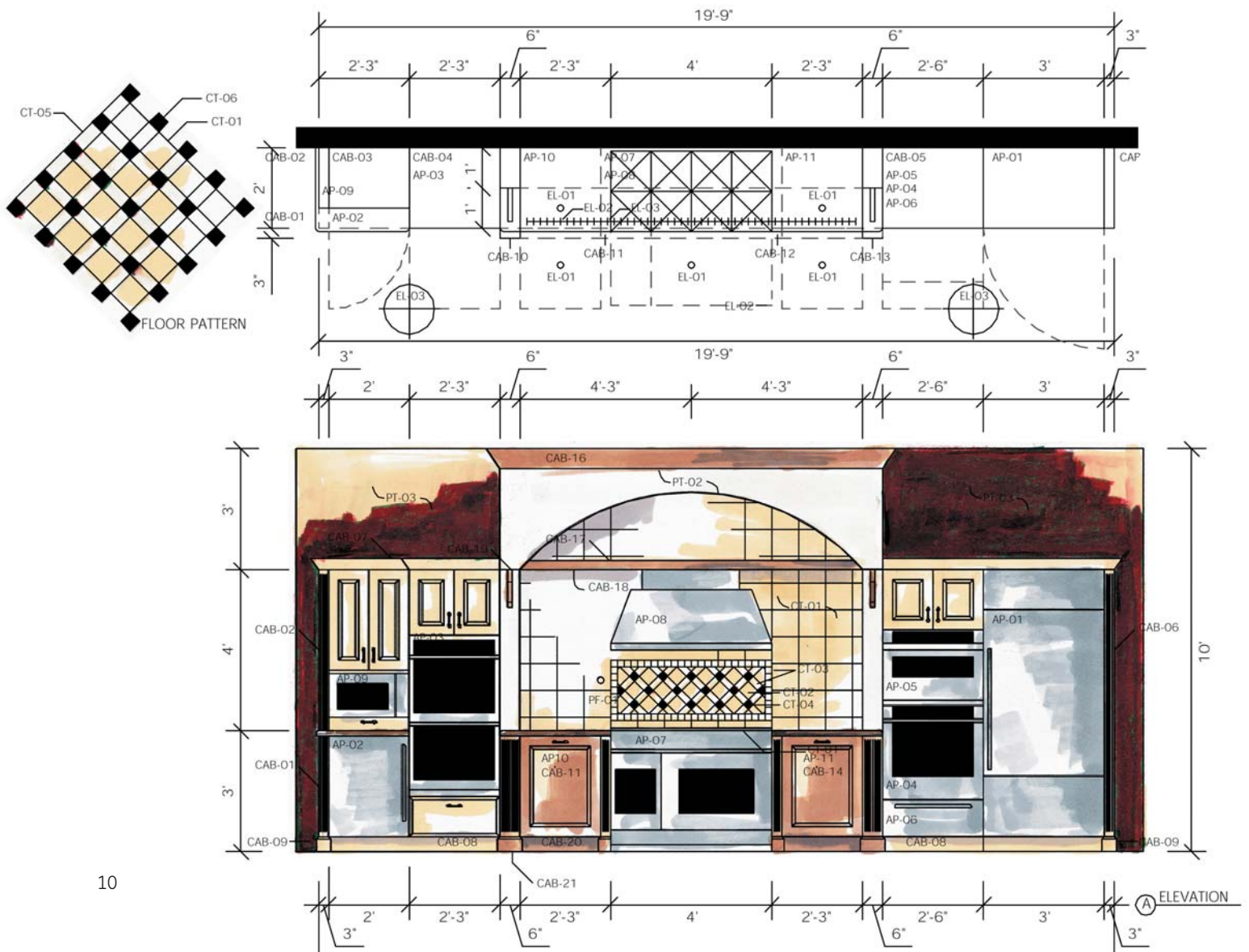



**Finished kitchen displays** are available for immediate design impact and differentiation. Simply order the display of your choice, and it will be delivered and professionally installed in your showroom.

**Versatile freestanding displays** created by a professional display developer give you another option for showcasing Monogram appliances. Completely self-contained, these modules work well on their own yet can be combined for maximum effect. Or, a local craftsman may fashion displays for you using the appliance cutout dimensions available at [monogram.com](http://monogram.com).



## Single and double integrated convection wall ovens

	ZET1SLSS	ZET2SLSS
<b>Description</b>	30" single oven	30" double oven
<b>Performance</b>		
Self-cleaning oven(s)	•	Upper and lower
Oven capacity	4.4 cu. ft.	4.4 cu. ft. (each oven)
Reverse-Air convection oven	•	Upper and lower
True hidden bake elements	•	•
Multi-rack convection bake	•	•
Single-rack convection bake	•	•
Convection roast	•	•
Convection broil	•	•
Standard/dual zone broil	Hi/Lo	Hi/Lo
Dual convection elements	•	•
Dual broil elements	•	•
Dual bake elements	•	•
208/240v performance compensation	•	•
Roasting rack	•	•
<b>Convenience</b>		
Electronic dial controls	•	•
Full-extension self-clean porcelain oven racks	3	3 (each oven)
Dual halogen light columns	6 lamps	6 lamps (each oven)
Self-clean delay option	•	•
Automatic meat thermometer	•	1 (each oven)
Digital temperature display	•	•
Electronic clock and kitchen timer	•	•
Delay bake option with Warm mode	•	•
Proof mode	•	•
Warm mode	•	•
Audible preheat signal	•	•
Auto oven shut-off w/override	•	•
Control lock capability	•	•
Certified Sabbath mode	•	•
<b>Appearance</b>		
Oven door(s)	Stainless steel	Stainless steel
Monogram tubular handle	•	•
Control knobs	Machined stainless steel	Machined stainless steel
Hand-polished, welded door seams	•	•
Undercounter installation	•	
<b>General features</b>		
Oven cabinet width required (in.)	30	30
Rack positions	5	5 (each oven)
Interior dimensions (WxHxD in inches)	upper lower	24 x 17-1/2 x 18-1/4 24 x 17-1/2 x 18-1/4
Overall dimensions (WxHxD in inches)	29-3/4 x 28-1/4 x 23-1/2	29-3/4 x 52-7/8 x 23-1/2
KW rating	@240VAC 208VAC	4.3 3.9
Amps rating	@240VAC 208VAC	8.6 7.8
Recommended circuit	@240VAC* 208VAC*	20 40
Approx. shipping weight (lbs.)	195	370
Limited warranty**	1-Year	1-Year

\*Check local codes

\*\*See written warranty for details.

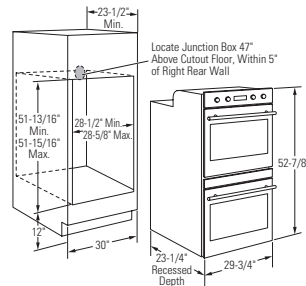
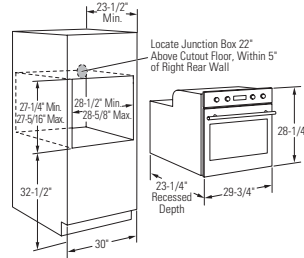



## Single and double professional convection wall ovens

Description	ZET1PLSS	ZET2PLSS
	30" single oven	30" double oven
<b>Performance</b>		
Self-cleaning oven(s)	•	Upper and lower
Oven capacity	4.4 cu. ft.	4.4 cu. ft. (each oven)
Reverse-Air convection oven	•	Upper and lower
True hidden bake elements	•	•
Multi-rack convection bake	•	•
Single-rack convection bake	•	•
Convection roast	•	•
Convection broil	•	•
Standard/dual zone broil	Hi/Lo	Hi/Lo
Dual convection elements	•	•
Dual broil elements	•	•
Dual bake elements	•	•
208/240v performance compensation	•	•
Roasting rack	•	•
<b>Convenience</b>		
Electronic dial controls	•	•
Full-extension self-clean porcelain oven racks	3	3 (each oven)
Dual halogen light columns	6 lamps	6 lamps (each oven)
Self-clean delay option	•	•
Automatic meat thermometer	•	1 (each oven)
Digital temperature display	•	•
Electronic clock and kitchen timer	•	•
Delay bake option with Warm mode	•	•
Proof mode	•	•
Warm mode	•	•
Audible preheat signal	•	•
Auto oven shut-off w/override	•	•
Control lock capability	•	•
Certified Sabbath mode	•	•
<b>Appearance</b>		
Oven door(s)	Stainless steel	Stainless steel
Monogram professional handle	•	•
Control knobs	Die-cast metal	Die-cast metal
Hand-polished, welded door seams	•	•
Undercounter installation	•	
<b>General features</b>		
Oven cabinet width required (in.)	30	30
Rack positions	5	5 (each oven)
Interior dimensions (WxHxD in inches)	upper lower	24 x 17-1/2 x 18-1/4 24 x 17-1/2 x 18-1/4
Overall dimensions (WxHxD in inches)	29-3/4 x 28-1/4 x 23-1/2	29-3/4 x 52-7/8 x 23-1/2
KW rating	@240VAC 208VAC	4.3 3.9
Amps rating	@240VAC 208VAC	17.9 18.7
Recommended circuit	@240VAC* 208VAC*	20 20
Approx. shipping weight (lbs.)	195	370
Limited warranty**	1-Year	1-Year

\*Check local codes

\*\*See written warranty for details.

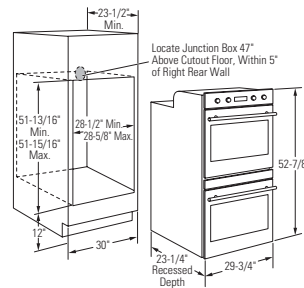
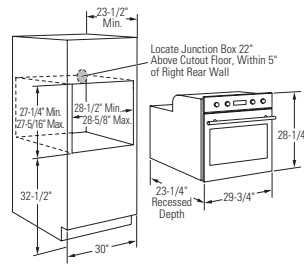



## Single and double Trivection® ovens

	ZET3038SHSS ZET3038BHBB	ZET3058SHSS ZET3058BHBB
<b>Description</b>	30" single oven	30" double oven
<b>Performance</b>		
Self-cleaning oven(s)	•	Upper and lower
Oven capacity	4.3 cu. ft.	4.3 cu. ft. upper 4.4 cu. ft. lower
Trivection technology	•	•
Trivection/convection oven	•	Upper
Convection oven	•	Lower
Reverse-Air convection	•	•
Multi-rack convection bake	•	•
Single-rack convection bake	•	•
Convection roast	•	•
Optional closed-door broiling	•	•
Speed bake/speed broil	• / •	Upper/upper
Convection element	2500W	2500W
Variable broil/six-pass broil element	•	•
Dual power bake element	•	Upper
Eight-pass bake element	•	Lower
Roasting rack	•	•
<b>Convenience</b>		
Electronic glass touch controls	•	•
Heavy duty oven racks	3	3 (each oven)
Halogen oven lights	2	2 (each oven)
Self-clean delay option	•	•
Auto Recipe™ conversion	•	•
Convection mode conversion	•	•
Digital temperature display	•	•
Delay bake option with warm mode	•	•
Proof, warm, defrost modes	•	•
Audible preheat signal	•	•
Auto oven shut-off w/override	•	•
Control lock capability	•	•
Certified Sabbath mode	•	•
<b>Appearance</b>		
Oven door(s)	Stainless steel Black painted steel	Stainless steel Black painted steel
Monogram tubular handle	•	•
Hand-polished, welded door seams	•	•
Undercounter installation	•	
<b>General Features</b>		
Oven cabinet width required (in.)	30	30
Rack positions	5	5 upper / 7 lower
Interior dimensions (WxHxD in inches)	upper lower	24 x 17-1/2 x 17-1/2 24 x 16-1/4 x 18-1/4
Overall dimensions (WxHxD in inches)	29-3/4 x 28-1/4 x 23-1/2	29-3/4 x 52-7/8 x 23-1/2
KW rating	@240VAC 208VAC	5.9 4.4
Amps rating	@240VAC 208VAC	24.6 21.2
Approx. shipping weight (lbs.)	199	333
Limited warranty*	1-year	1-year

\*See written warranty for details.

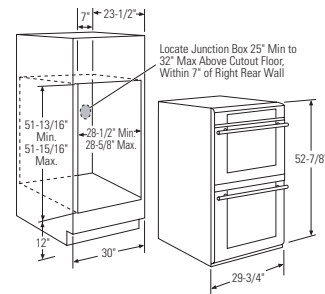
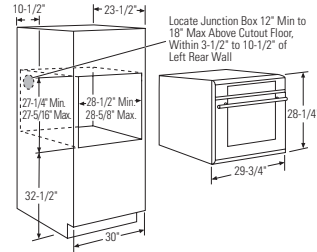



## Single and double convection ovens

	ZET938SFSS ZET938BFBB ZET938WFWW	ZET958SFSS ZET958BFBB ZET958WFWW	ZEK938SFSS ZEK938BFBB	ZEK958SFSS ZEK958BFBB
<b>Description</b>	30" single oven	30" double oven	27" single oven	27" double oven
<b>Performance</b>				
Self-cleaning oven(s)	•	Upper and lower	•	Upper and lower
Oven capacity	4.1 cu. ft.	4.1 cu. ft. (each oven)	3.9 cu. ft.	3.9 cu. ft. (each oven)
Reverse-Air convection oven	•	Upper and lower	•	Upper and lower
Hidden bake element	•	•	•	•
Multi-rack convection bake	•	•	•	•
Single-rack convection bake	•	•	•	•
Optional closed-door broiling	•	•	•	•
Convection element	2500W	2500W	2500W	2500W
Variable broil/broil element	3600W; 6-pass	3600W; 6-pass	3400W; 4-pass	3400W; 4-pass
Bake element	2700W; 8-pass	2700W; 8-pass	2650W; 6-pass	2650W; 6-pass
Roasting rack	•	•	•	•
<b>Convenience</b>				
Electronic glass touch controls	•	•	•	•
Self-clean porcelain oven racks	3	3 (each oven)	3	3 (each oven)
Concealed bake element	•	•	•	•
Halogen oven lights	2	2 (each oven)	2	2 (each oven)
Self-clean delay option	•	•	•	•
Convection mode conversion	•	•	•	•
Automatic meat thermometer	•	1 (each oven)	•	1 (each oven)
Digital temperature display	•	•	•	•
Electronic clock and kitchen timer	•	•	•	•
Delay bake option with Warm mode	•	•	•	•
Proof mode	•	•	•	•
Warm mode	•	•	•	•
°C or °F programmable	•	•	•	•
Audible preheat signal	•	•	•	•
Auto oven shut-off w/override	•	•	•	•
Control lock capability	•	•	•	•
Certified Sabbath mode	•	•	•	•
<b>Appearance</b>				
Oven door(s)	Stainless steel Black painted steel White painted steel	Stainless steel Black painted steel White painted steel	Stainless steel Black painted steel	Stainless steel Black painted steel
Monogram tubular handle	•	•	•	•
Hand-polished, welded door seams	•	•	•	•
Undercounter installation	•	•	•	•
<b>General features</b>				
Oven cabinet width required (in.)	30	30	27	27
Rack positions	7	7 (each oven)	4	4 (each oven)
Interior dimensions upper		24 x 16-1/4 x 18-1/4		21-1/2 x 17 x 18-1/4
WxHxD in inches lower	24 x 16-1/4 x 18-1/4	24 x 16-1/4 x 18-1/4	21-1/2 x 17 x 18-1/4	21-1/2 x 17 x 18-1/4
Overall dimensions WxHxD in inches	29-3/4 x 28-1/4 x 23-1/4	29-3/4 x 52-7/8 x 23-1/4	26-5/8 x 29 x 23-1/4	26-5/8 x 51 x 23-1/4
KW rating @240VAC	3.6	7.2	3.4	6.8
@208VAC	2.7	5.4	2.6	5.1
Amps rating @240VAC	15	30	15	28.3
@208VAC	13	26	13	24.5
Approx. shipping weight (lbs.)	135	260	100	164
Limited warranty*	1-Year	1-Year	1-Year	1-Year

\*See written warranty for details.

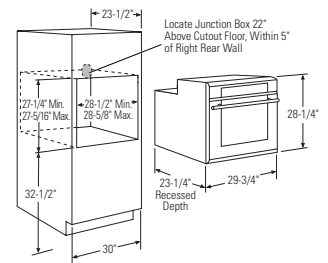
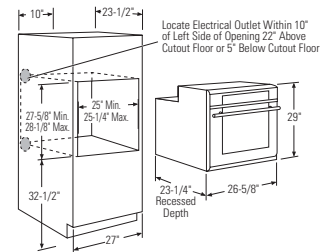
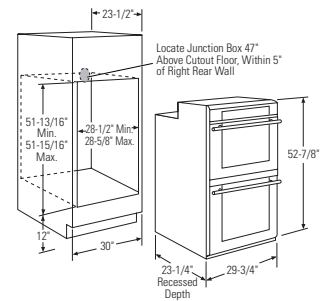
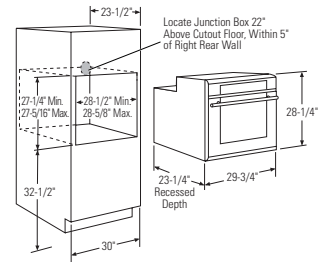



**GE Consumer & Industrial**  
Appliances  
General Electric Company  
Louisville, KY 40225  
ge.com

monogram.com