

GSH22JFT

GE® ENERGY STAR® 22.0 Cu. Ft. Side-By-Side Refrigerator with Dispenser

Dimensions and Installation Information (in inches)

Overall Dimensions	Height to top of hinge (in.) A	67-1/2
	Height to top of case (in.) B	66-1/2
	Case depth without door (in.) C†	28
	Case depth less door handle (in.) D†	31-1/4
	Case depth with door handle (in.) E†	33-9/16
	Depth with fresh food door open 90° (in.) F†	49-3/8
	Width (in.) G	33-1/2
	Width with door open 90° inc. door handle (in.) H	35-15/16
Air Clearances	Each side (in.)	1/8
	Top (in.)	1
	Back (in.)	1

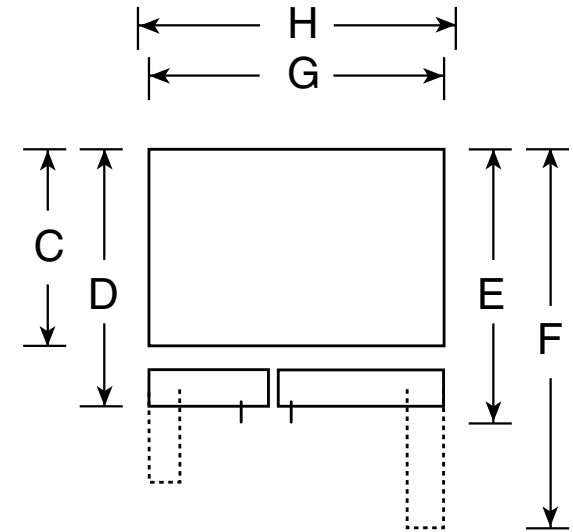
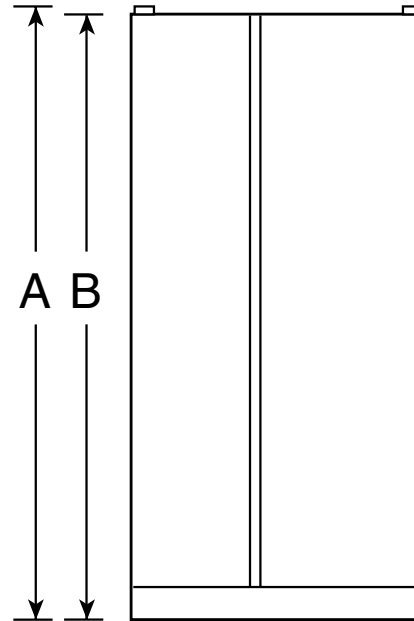

Top View

†Water hook-up fits in back air clearance when calculating installation depth.

If installed against a wall, allow clearance of 14-3/16" on freezer side to remove bin.

Clearance required to remove fresh food full-size pan without disassembling is 18-15/16".

Allow additional space for any necessary leveling adjustments.

For answers to your Monogram®, GE Profile™ or GE® appliance questions, visit our website at ge.com or call GE Answer Center® service, 800.626.2000.



As an ENERGY STAR® partner, GE has determined that this product meets the ENERGY STAR guidelines for energy efficiency.

GSH22JFT

GE® ENERGY STAR® 22.0 Cu. Ft. Side-By-Side Refrigerator with Dispenser

Features and Benefits

- External Temperature Controls with Child Lock - Combines the ease of 0-9 temperature settings, with the sophistication of electronic controls
- Adjustable Humidity Vegetable/Fruit Crisper - Provides easy storage environment for fruits and vegetables
- Adjustable Temperature Deli Drawer - Keep meats and cheeses fresher, longer
- Snack Pan - Helps keep everyday foods like muffins and carrot sticks fresh
- Adjustable Gallon Door Bins - Make room for milk and other gallon-size containers
- AutoEnergy Saver - Senses freezer and fresh door openings and adjusts refrigeration operation cycles accordingly
- GE SmartWater™ Filtration System - Delivers clean great-tasting water and ice through the LightTouch! Dispenser
- FrostGuard™ Technology - Protects frozen items from freezer burn by monitoring freezer door openings and defrosting only when needed
- Deluxe Quiet Design - Significantly reduces operating noise
- NeverClean™ Condenser - Condenser coils are encased, so they don't require cleaning in normal operating environments
- Model GSH22JFTWW - White on white
- Model GSH22JFTCC - Bisque on bisque
- Model GSH22JFTBB - Black on black

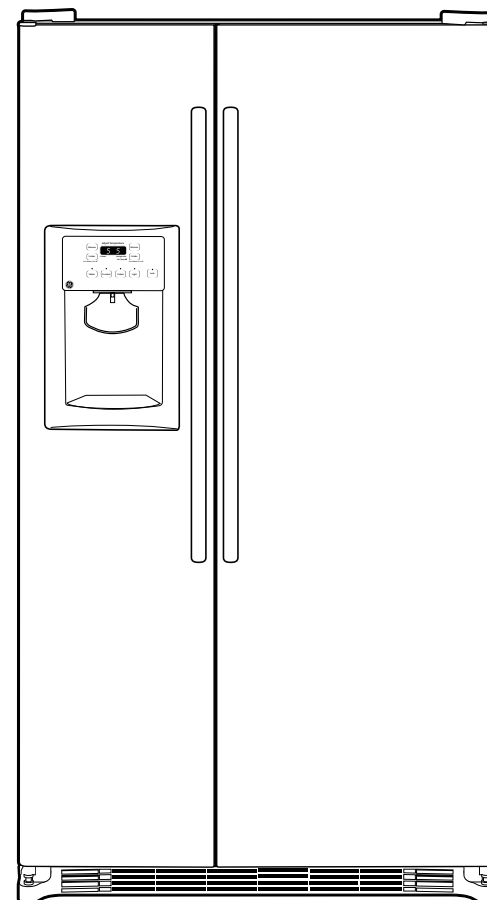

imagination at work



As an ENERGY STAR® partner, GE has determined that this product meets the ENERGY STAR guidelines for energy efficiency.