

GTH21SCX

GE® ENERGY STAR® 21.0 Cu. Ft. Top-Freezer Refrigerator

Dimensions and Installation Information (in inches)

Overall Dimensions	Height to top of hinge (in.) A	66-3/4
	Height to top of case (in.) B	66
	Case depth without door (in.) C†	27
	Case depth less door handle (in.) D†	30-1/2
	Case depth with door handle (in.) E†	31-1/4
	Depth with fresh food door open 90° (in.) F†	60-3/4
	Width (in.) G	32-3/4
	Width with door open 90° inc. door handle (in.) H	36-1/2
Air Clearances	Each side (in.)	1/8
	Top (in.)	1/2
	Back (in.)	1/2

*Height to mid-freezer (in.): 55

Note: All Top-Freezer No-Frost Right-Hand Refrigerator Doors:
As you face the front of the refrigerator, the handle is on your left and the hinges are on your right.

Note: Top-Freezer No-Frost Left-Hand Refrigerator Doors:
As you face the front of the refrigerator, the handle is on your right and the hinges are on your left.

For answers to your Monogram®, GE Profile™ or GE® appliance questions, visit our website at ge.com or call GE Answer Center® service, 800.626.2000.

Front View

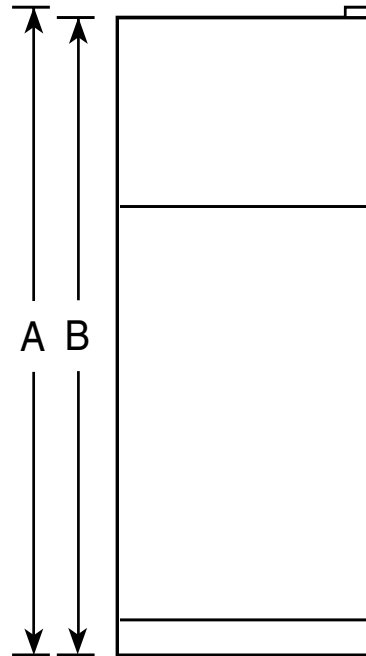

Top View

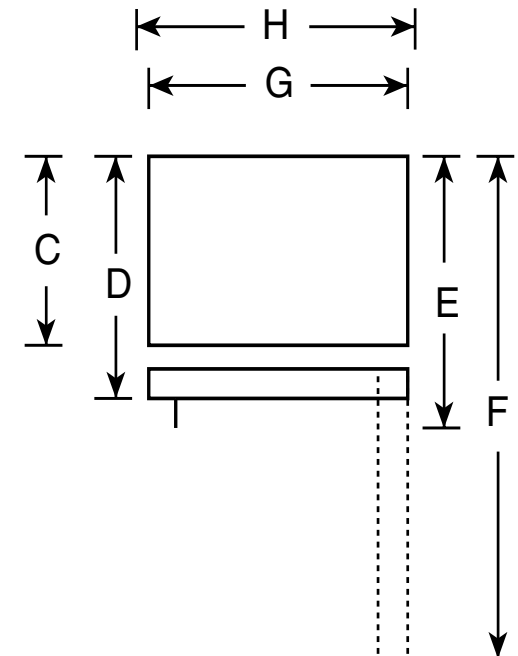

imagination at work



Total volume and shelf area are calculated by the Association of Home Appliance Manufacturers' standards.



Listed by Underwriters Laboratories



As an ENERGY STAR® partner, GE has determined that this product meets the ENERGY STAR guidelines for energy efficiency.

Specification Created 5/08

130326

GTH21SCX

GE® ENERGY STAR® 21.0 Cu. Ft. Top-Freezer Refrigerator

Features and Benefits

- Stainless steel exterior - Stainless steel adds elegance to any kitchen décor
- Adjustable spill-resistant glass shelves - Shelves are designed to keep spills from creating bigger messes
- Factory-installed icemaker - Refrigerator comes ready to automatically create ice
- Adjustable-humidity crisper drawers - Adjustable humidity controls keep fresh produce fresh
- Snack drawer - Conveniently stores favorite foods and allows for quick, easy access
- Upfront temperature controls - A simple knob turn regulates interior temperatures with ease
- Wire freezer shelves - Sturdy shelves provide additional storage for frozen foods
- NeverClean™ condenser - Sealed compartment keeps coils clean and simplifies maintenance
- Deluxe quiet design - Significantly reduces unnecessary operating noise in the kitchen
- Model GTH21SCXSS - Stainless steel

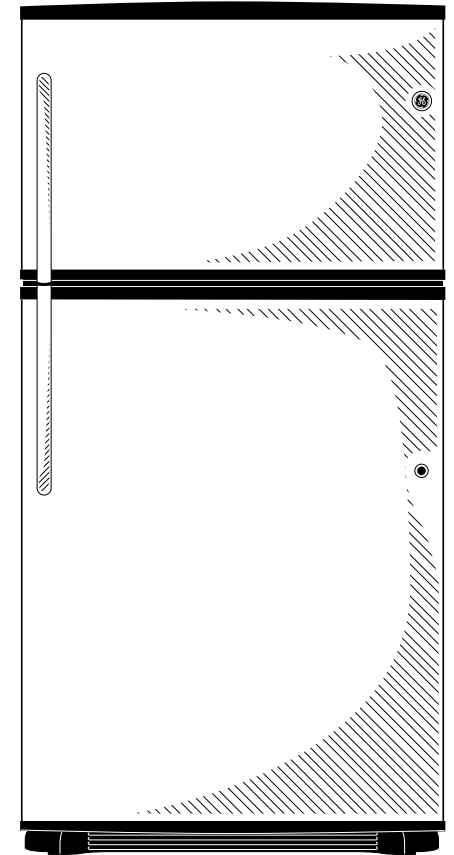

imagination at work