

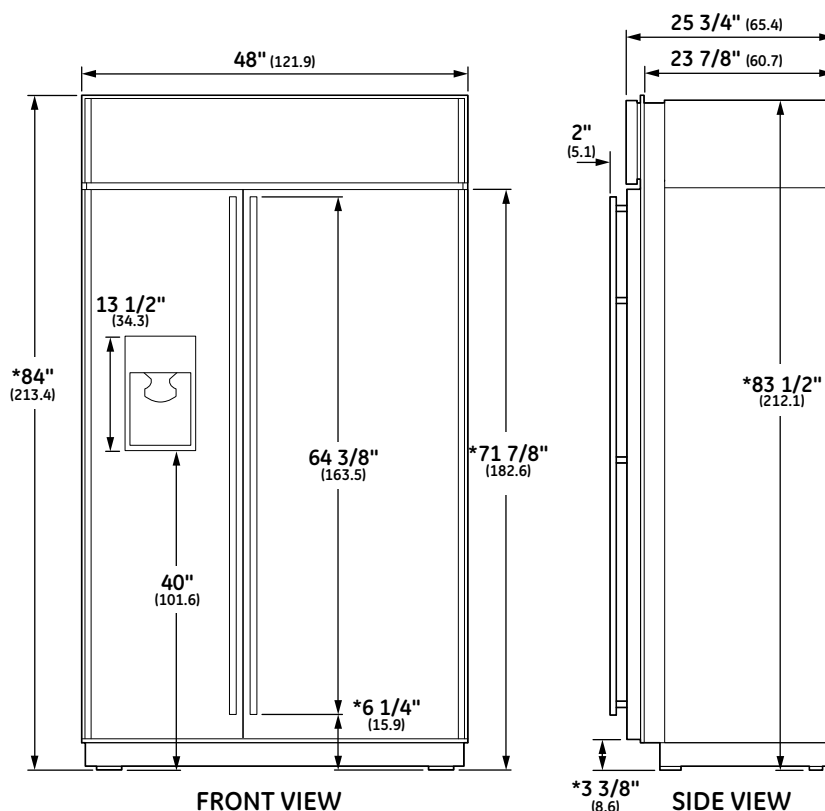

OVERALL DIMENSIONS



\* Shipping height. Use leveling legs and wheels for maximum 1" height adjustment from shipping height.

SPECIFICATIONS

Overall Width	48" (121.92 cm)
Overall Height	84" (213.36 cm)
Overall Depth	25 3/4" (65.41 cm)
Door Clearance	28 5/8" (72.7 cm)
Cutout Width	47 1/2" (120.7 cm)
Cutout Height	83 1/2" - 84 1/2" (212.1 - 214.6 cm)
Cutout Depth	24" (61 cm)
Plumbing Requirements	1/4" OD copper tubing or GE SmartConnect kit
Shipping Weight	775 lb

**ATTENTION ELECTRICIAN:**  
 A 115 volt 60Hz., 15 or 20 amp power supply is required. An individual properly grounded branch circuit or circuit breaker is recommended. Install a properly grounded 3-prong electrical receptacle recessed into the back wall.

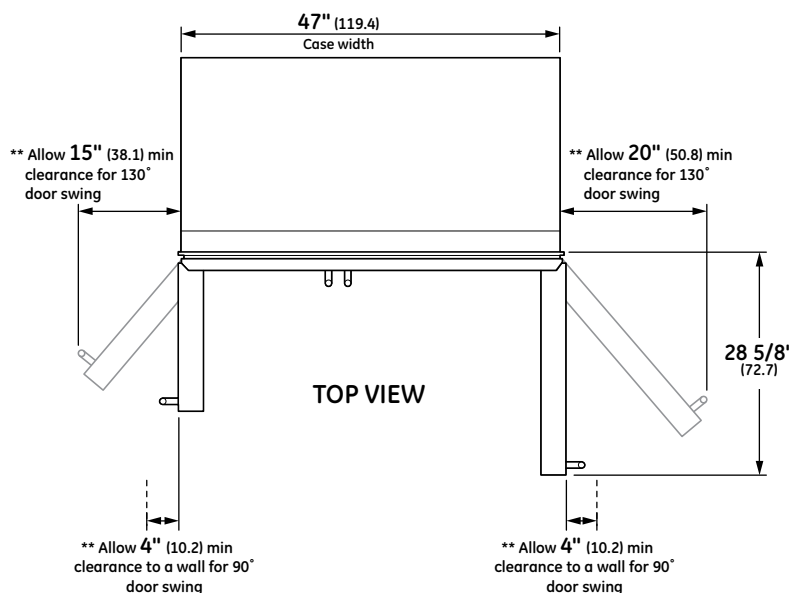

\*\* These refrigerators are equipped with a 2-position door stop. The factory-set 130° door swing can be adjusted to 90° if clearances to adjacent cabinets or walls is restricted. Allow full 130° door swings for pan removal. If the 90° door stop position is used, pan access is maintained, but pan removal is restricted.

Dimensions in parentheses are in centimeters unless otherwise noted. Actual product dimension may vary due to manufacturing tolerances.



STANDARD INSTALLATION

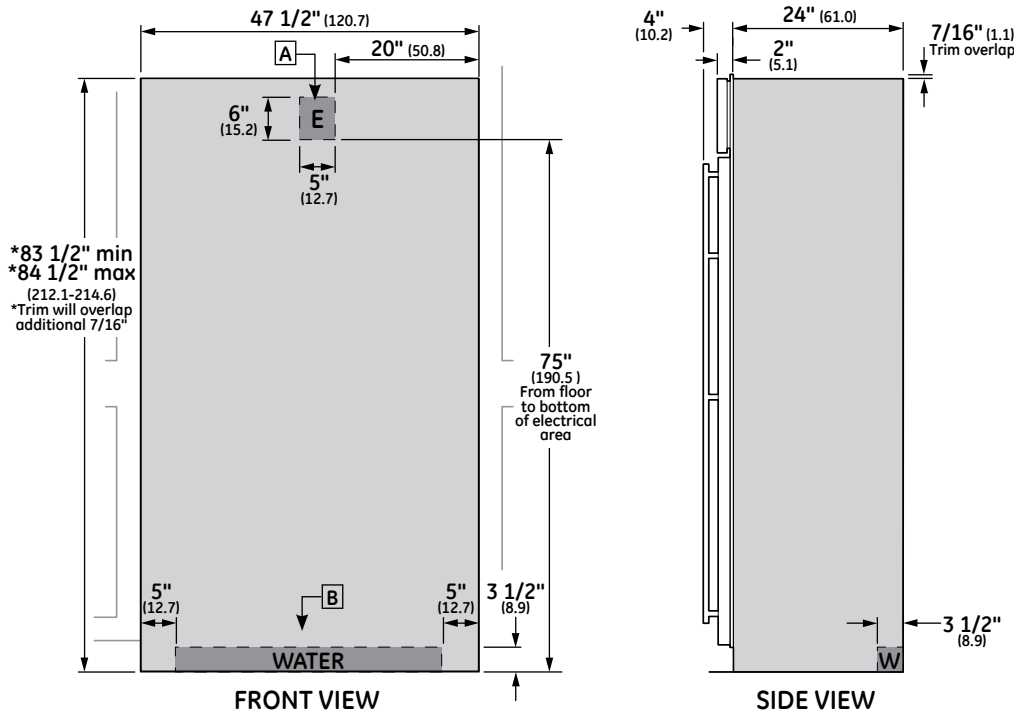

The refrigerator will project forward, slightly beyond adjacent cabinetry.

NOTES

**A** Mounting the junction box in this location will also allow for front accessibility through access panel.

**B** Water supply area.

**! WARNING:**  
The refrigerator is top heavy and must be secured to prevent the possibility of tipping forward. Failure to do so may result in death or serious injury.  
The information below is for cabinet design only. **When installing the anti-tip system you must use the product installation instructions.**

Determine your installation construction and required anti-tip configuration:

**C** Installed Under Soffit  
After installing unit into installation opening, raise grille panel and screw metal case sides to adjacent cabinet. When installed under a soffit, the soffit cannot exceed 24" deep. The top case trim overlaps the bottom of the soffit.

**D** Wooden Wall Studs and No Soffit  
• Cut a 2" x 4" block and secure to brackets provided.

• Secure brackets to back wall of opening at 84" or your installation height from the floor.

**E** Metal Wall Studs and No Soffit

This method requires securely fastened cabinets on both sides and a 3/4" minimum wood brace above unit, with it's front surface 24" from back wall.

• After installing unit into opening, raise grille panel and attach metal case top trim to 3/4" minimum wood brace.

• The brace spanning the enclosure must be securely fastened to cabinets on both sides.

See Installation Instructions for detailed instructions.

ANTI-TIP BRACKET

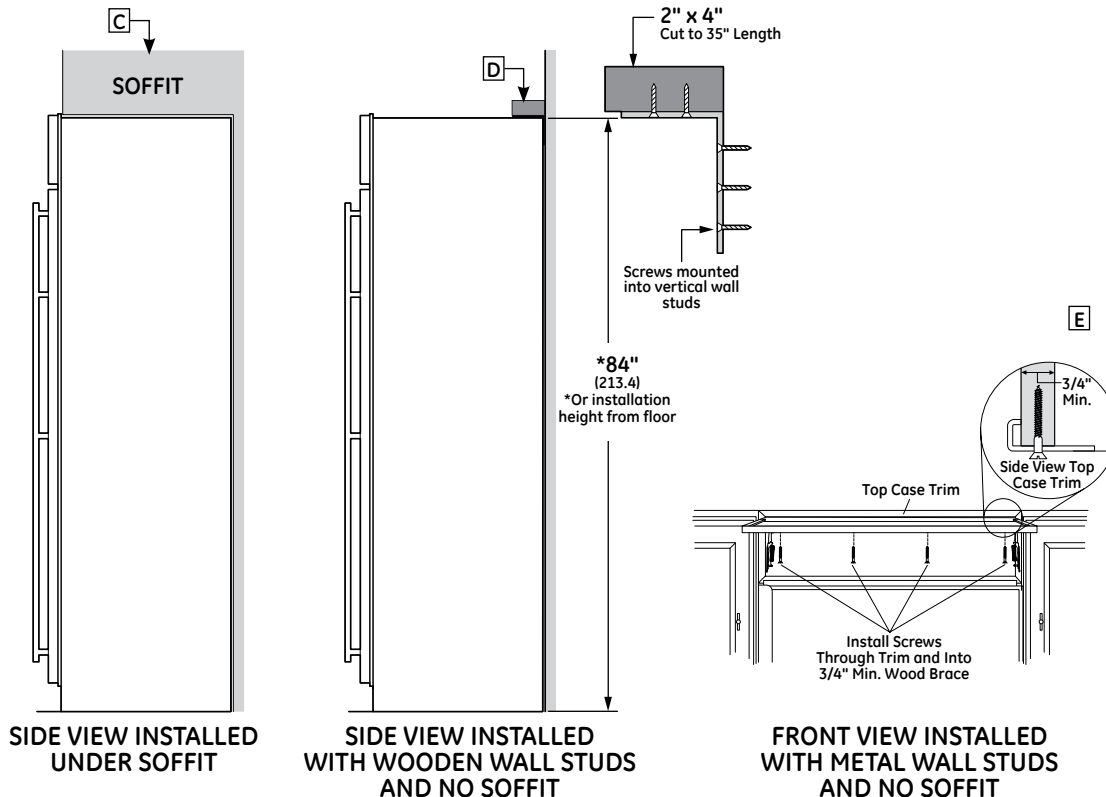

CUSTOM SIDE PANELS

F

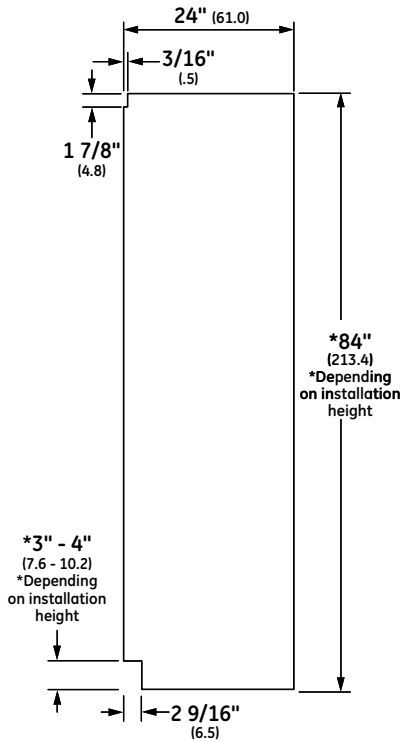

NOTES

F Side panels must be used whenever the sides of the refrigerator will be exposed. The 1/4" side panels will slip into the side case trim. Secure the panels to the refrigerator with stick-on hook and loop fastener strips. Order the side panels from the cabinet manufacturer.

## FEATURES AND BENEFITS

**Halogen Light Columns** - Located in the freezer and fresh food compartments, extend the full length of the interior compartments providing brilliant, all-level illumination

**LED Lighting** - Located at the top of the fresh food compartment, and inside the vegetable and climate-control drawers, illuminates contents without compromising space

**Advanced Temperature Management System with Multi-Shelf Air Tower** - Provides even distribution of air throughout the refrigerator

**Climate-Control Drawer** - Allows you to express-chill beverages, express-thaw meats and select specific temperatures for perishable foods

**Dispenser with Proximity Sensor** - Designed to accommodate glassware of all sizes, from pitchers to tumblers; control graphics light up as you approach and automatically switch off when you walk away

**Filter-Change Indicator Light** - Located on the upfront control panel, provides a visual reminder when it's time to replace the filter for the water dispenser

**GE® Water Filter** - Has been moved from the fresh food compartment to the overhead cabinet, where it is discreetly out of sight

**Dairy Bin with Center Divider** - Has a unique magnetic seal that locks in freshness

