

Upright FREEZERS

SAFETY INFORMATION 2

USING THE FREEZER 4

CARE AND CLEANING 11

TROUBLESHOOTING TIPS 13

WARRANTY 17

CONSUMER SUPPORT 18

OWNER'S MANUAL

MUF06DMRWW

ENGLISH/FRANÇAIS

Write the model and serial numbers here:

Model # _____

Serial # _____

IMPORTANT SAFETY INFORMATION

READ ALL INSTRUCTIONS BEFORE USING THE APPLIANCE

⚠ WARNING To reduce the risk of fire, explosion, electric shock, or injury when using your freezer, follow these basic safety precautions:

- This freezer must be properly installed and located in accordance with the Installation Instructions before it is used.
- Unplug the freezer before making repairs or cleaning.
NOTE: Power to the freezer cannot be disconnected by any setting on the control panel.
NOTE: Repairs must be performed by a qualified Service Professional.
- Replace all parts and panels before operating.
- Do not store or use gasoline or other flammable vapors and liquids in the vicinity of this or any other appliance.
- Do not store explosive substances such as aerosol cans with a flammable propellant in this appliance.
- Do not use an extension cord.
- To prevent suffocation and entrapment hazards to children, remove the lid from any freezer before disposing of it or discontinuing its use.
- To avoid serious injury or death, children should not stand on, or play in or with the appliance.
- Children and persons with reduced physical, sensory or mental capabilities or lack of experience and knowledge can use this appliance only if they are supervised or have been given instructions on safe use and understand the hazards involved.
- This appliance is intended to be used in household and similar applications such as: staff kitchen areas in shops, offices and other working environments; farm houses; by clients in hotels, motels, bed & breakfast and other residential environments; catering and similar non-retail applications.

⚠ CAUTION To reduce the risk of injury when using your freezer, follow these basic safety precautions.

- Do not clean freezer with warm water when it is cold. Components may break if exposed to sudden temperature changes or impact, such as bumping or dropping.
- Keep fingers out of the “pinch point” areas; clearances between the lid and cabinet are necessarily small. Be careful closing lid when children are in the area.
- Do not touch the cold surfaces in the freezer compartment when hands are damp or wet, skin may stick to these extremely cold surfaces.
- Do not refreeze frozen foods which have thawed completely.

⚠ WARNING  **EXPLOSION HAZARD Flammable Refrigerant**

This appliance contains isobutane refrigerant, R600a, a natural gas with high environmental compatibility. However, it is also combustible. Adhere to the warnings below to reduce the risk of injury or property damage.

1. When handling, installing and operating the appliance, care should be taken to avoid damage to the refrigerant tubing.
2. Service shall only be performed by authorized service personnel. Use only manufacturer-authorized service parts.
3. Dispose of appliance in accordance with Federal and Local Regulations. Flammable refrigerant and insulation material used require special disposal procedures. Contact your local authorities for the environmentally safe disposal of your appliance.
4. Keep ventilation openings in the appliance enclosures or in the built-in structure clear of obstruction.
5. Do not use mechanical devices or other means to accelerate the defrosting process.
6. Do not damage refrigerant circuit.
7. Do not use electrical appliances inside the food storage compartment of the appliance.

STATE OF CALIFORNIA PROPOSITION 65 WARNINGS:

⚠ WARNING This product contains one or more chemicals known to the State of California to cause cancer and birth defects or other reproductive harm.

READ AND SAVE THESE INSTRUCTIONS

IMPORTANT SAFETY INFORMATION

READ ALL INSTRUCTIONS BEFORE USING THE APPLIANCE

INSTALLATION

⚠ WARNING EXPLOSION HAZARD

Keep flammable materials and vapors, such as gasoline, away from freezer. Failure to do so can result in fire, explosion, or death.

CONNECTING ELECTRICITY

⚠ WARNING ELECTRICAL SHOCK HAZARD

Plug into a grounded 3-prong outlet.

Do not remove the ground prong.

Do not use an adapter.

Do not use an extension cord.

Failure to follow these instructions can result in death, fire, or electrical shock.

Do not, under any circumstances, cut or remove the third (ground) prong from the power cord. For personal safety, this appliance must be properly grounded.

The power cord of this appliance is equipped with a 3-prong (grounding) plug which mates with a standard 3-prong (grounding) wall outlet to minimize the possibility of electric shock hazard from this appliance.

Have the wall outlet and circuit checked by a qualified electrician to make sure the outlet is properly grounded.

Where a standard 2-prong wall outlet is encountered, it is your personal responsibility and obligation to have it replaced with a properly grounded 3-prong wall outlet.

The freezer should always be plugged into its own individual electrical outlet which has a voltage rating that matches the rating plate.

A 115 Volt AC, 60 Hz, 15- or 20-amp fused, grounded electrical supply is required. This provides the best performance and also prevents overloading house wiring circuits which could cause a fire hazard from overheated wires.

Never unplug your freezer by pulling on the power cord. Always grip plug firmly and pull straight out from the outlet.

Immediately discontinue use of a damaged supply cord. If the supply cord is damaged, it must be replaced by a qualified service professional with an authorized service part from the manufacturer.

When moving the freezer away from the wall, be careful not to roll over or damage the power cord.

PROPER DISPOSAL OF YOUR OLD APPLIANCE

⚠ WARNING SUFFOCATION AND ENTRAPMENT HAZARD

Failure to follow these disposal instructions can result in death or serious injury

IMPORTANT: Child entrapment and suffocation are not problems of the past. Junked or abandoned appliances are still dangerous even if they will sit for “just a few days.” If you are getting rid of your old appliance, please follow the instructions below to help prevent accidents.

Before You Throw Away Your Old Freezer:

- Take off the freezer lid.
- Leave the baskets in place so that children may not easily climb inside.

Refrigerant and Foam Disposal:

Dispose of appliance in accordance with Federal and Local Regulations. Flammable refrigerant and insulation material used require special disposal procedures. Contact your local authorities for the environmentally safe disposal of your appliance.

READ AND SAVE THESE INSTRUCTIONS

Features

Note: The illustrations shown in this user guide are only for reference. The actual product may differ slightly.

Package contents:

- 5.3 cubic foot upright freezer
- User Guide

Product dimensions

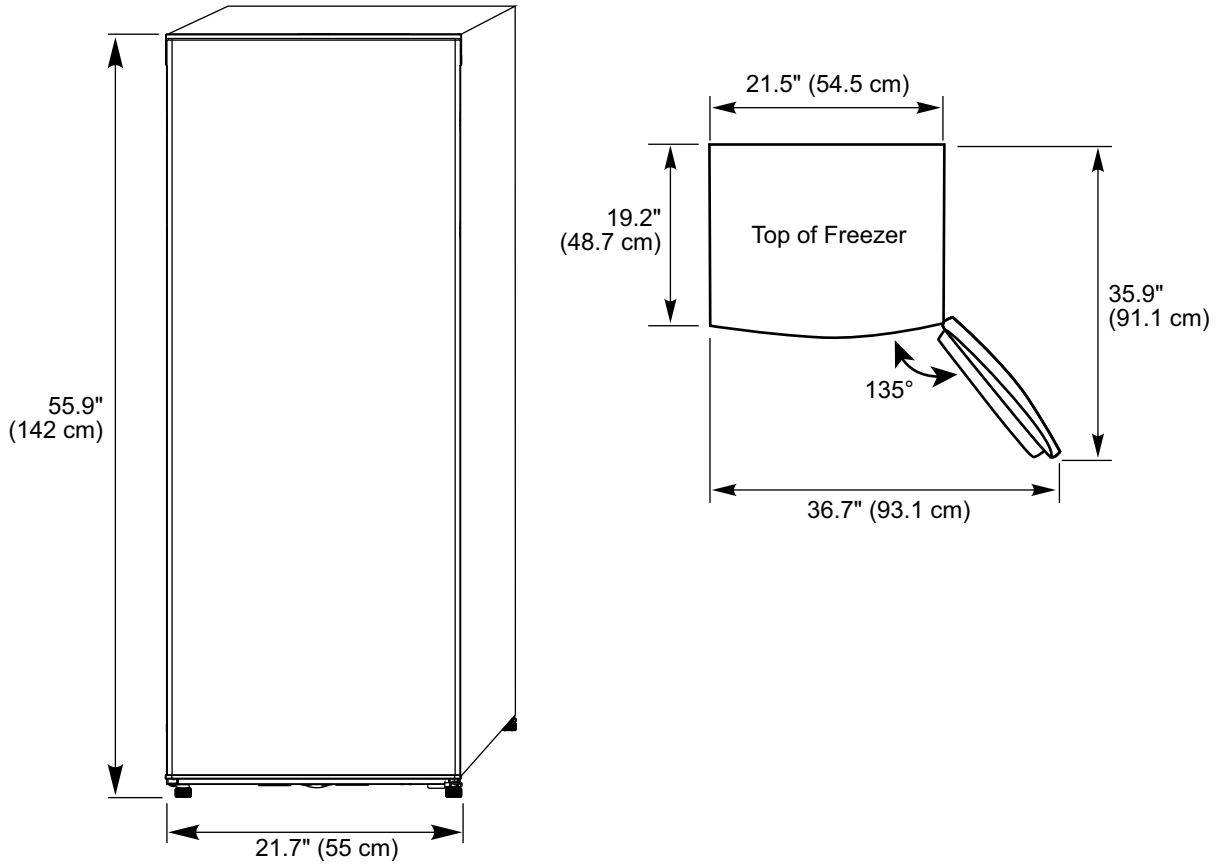

Interior

Notes:

- The four upper shelves measure 14.9 × 12.6" (37.8 × 32.1 cm) (W × D)
- The bottom shelf measures 15.2 × 6.6" (38.5 × 16.8 cm) (W × D)
- You can remove the bottom shelf.

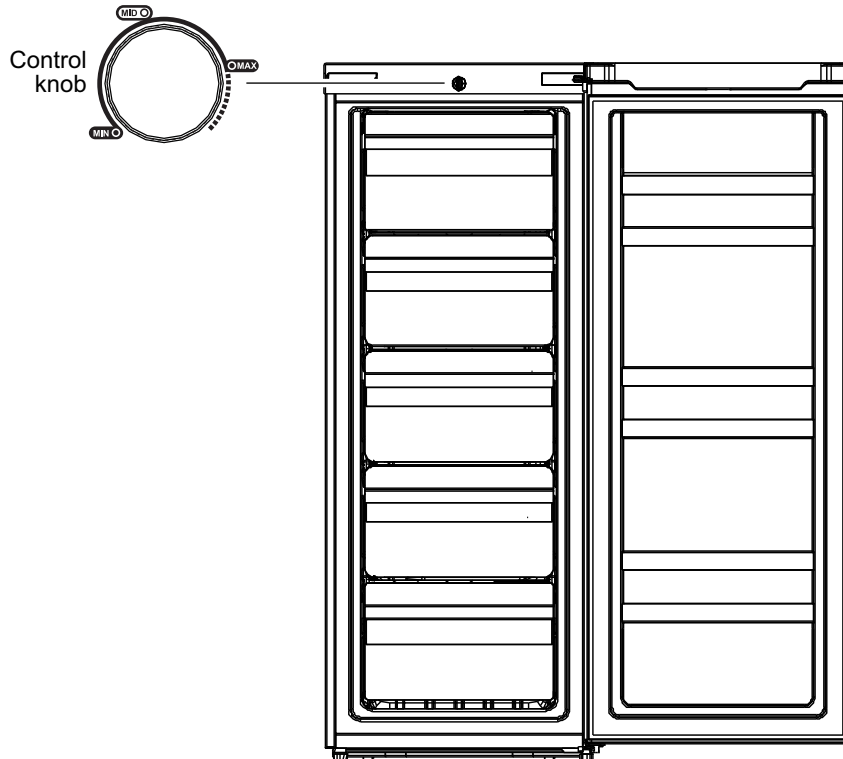

Setting up your freezer

Before using your freezer

- Remove the exterior and interior packing material including the bottom cushions, foam pads, and tape inside your freezer. Remove the plastic film from the door and sides.
- Let your freezer stand upright for approximately 30 minutes before connecting it to power. This reduces the possibility of a malfunction in the cooling system from incorrect handling during transportation.
- Before placing any fresh or frozen foods, let your freezer run for two to three hours. If the ambient temperature is high, for example in summer, wait for four or more hours.
- Wash the inside with a damp, warm cloth and a baking soda solution (two tablespoons in a quart of water), then wipe dry with a dry cloth. Do this periodically to keep your freezer looking new.
- For correct operation, you should level your freezer using the leveling feet. If you do not level your freezer, the door may not close or seal correctly, causing cooling, frost, and moisture problems. Turn the leveling feet clockwise to raise or counterclockwise to lower a side. The leveling feet are easier to adjust if you have someone push against the top of your freezer to take some weight off.
- When moving your freezer, do not tilt it beyond 45° from upright position.

Finding a suitable location

- Place your freezer on a floor that is strong enough to support your freezer when it is fully loaded.
- Do not install your freezer on carpeting or a rug.
- Your freezer is designed to be free standing and should not be recessed or built-in.
- If you use your freezer in a garage, make sure that the ambient temperature is between 5 °F and 190 °F (-15 °C and 43 °C).
- Allow 3.9 inches (20 cm) of space between the sides of your freezer and the surrounding walls, 3.9 inches (10 cm) between the back of your freezer and the wall, and 11.8 inches (30 cm) between the top of your freezer and the ceiling. This allows for correct air ventilation. Adjust the feet to keep your freezer level.
- If you locate your freezer next to a fixed wall, allow sufficient space on the hinge side for the door to swing open.
- Position your freezer away from direct sunlight and sources of heat, such as a stove, heater, or radiator. Direct sunlight may affect the acrylic coating and heat sources may increase electrical consumption. Extremely cold temperatures may also prevent your freezer from performing correctly.
- Avoid locating your freezer in moist areas.

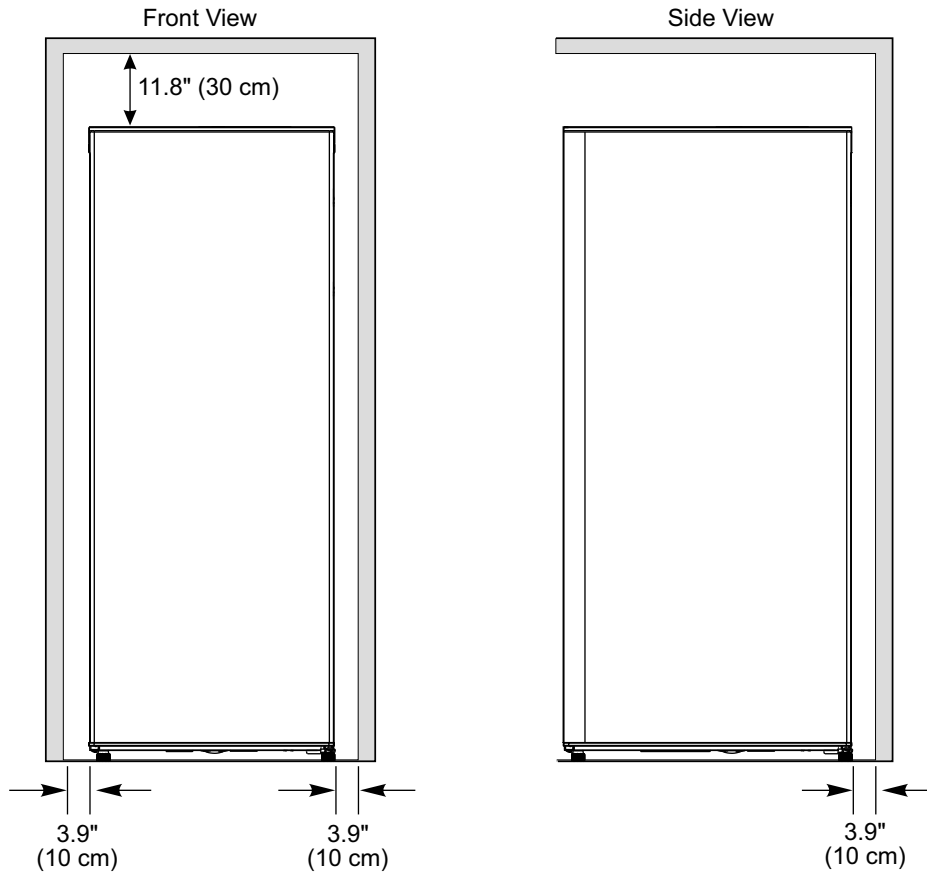

Leveling your freezer

- Leveling your freezer is important. If you do not level your freezer during installation, the doors may not close or seal correctly which can cause cooling, frost, or moisture problems.
 - To level your freezer, rotate the leveling feet clockwise (to raise) your freezer or counter-clockwise (to lower it).
- Note:** To make it easier to adjust the feet, have someone push against the top of your freezer to tilt it slightly.

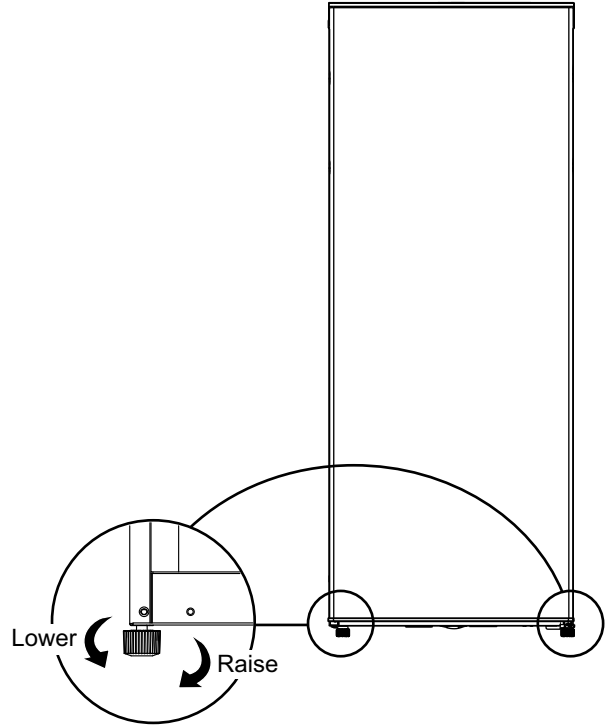

Reversing the freezer door

- Unplug your freezer before you reverse the door. Failure to unplug your freezer may result in serious injury or death from electrical shock.
- To avoid personal injury and property damage, get another person to help you reverse the door.

You will need the following tools to reverse the freezer door:

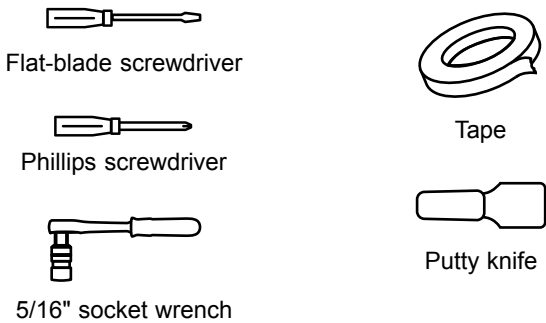

1. Unplug your freezer.
2. Remove the hinge cover, then remove the top hinge screws and hinge from your freezer. Remove the pin from the top edge of the door, then remove the hole cover from the other side of the freezer.

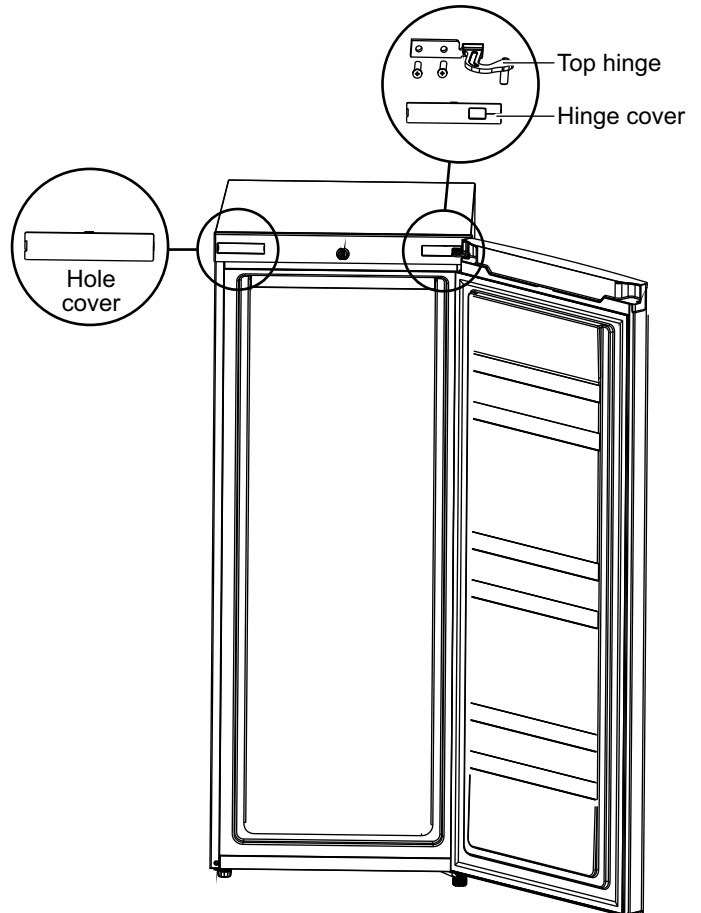

Reversing the freezer door (cont.)

3. While one person tilts your freezer backwards, remove the bottom hinge screws and hinge and the two leveling feet. Install the bottom hinge and leveling feet on the other side.

Tip: You can lay your freezer flat on the floor to make removing and installing the bottom hinge easier. If you do lay it flat, when you return it to the upright position, wait two hours before you plug it in.

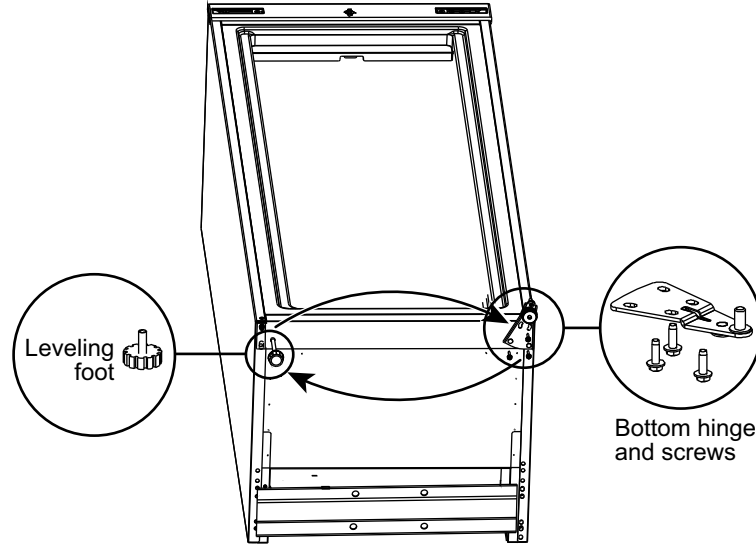

4. Remove the door stopper, then install it on the other side.

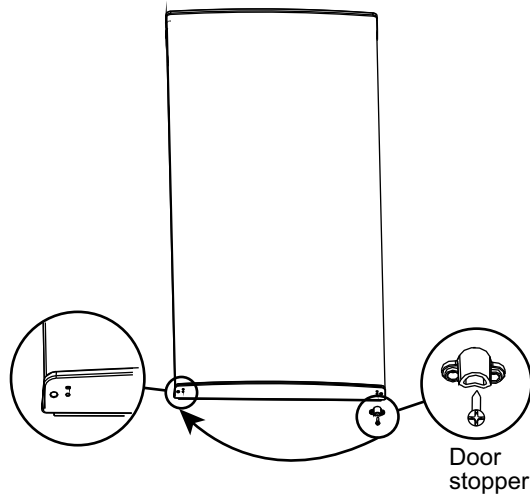

5. Align the door bottom so that the pin on the hinge slides into the hole in the door bottom.

Reversing the freezer door (cont.)

6. Align the hinge with the screw holes on the door and the hole in the top edge of the door. Slide the pin through the hole in the hinge and into the hole on the top edge of the door. Use the screws to attach the hinge to your freezer. Place the hole cover over the hinge opening on the other side of the door.

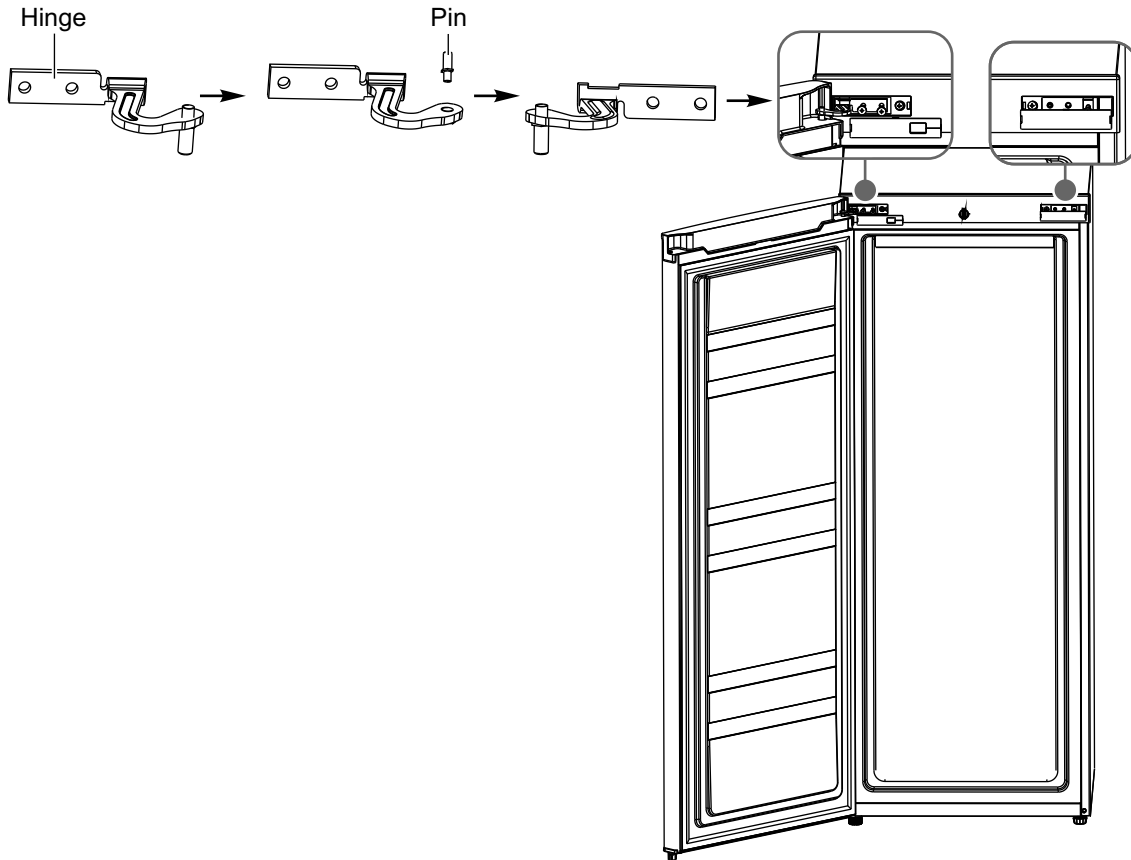

Providing the correct power source

Check your local power source. Your freezer requires a 115 V, 60 Hz power supply.

Make sure that:

- The power outlet accepts a 3-prong grounding plug. The third prong on the power cord plug grounds your freezer to minimize the possibility of electric shock. Do not modify the power plug.
- You DO NOT plug anything else into the same power outlet as your freezer. You may overload the circuit which can cause a fire.
- You DO NOT use an extension cord. If your freezer is too far from the power outlet, move your freezer or have an electrician install a plug closer to your freezer.
- The power outlet cannot be turned off with a switch or pull string.

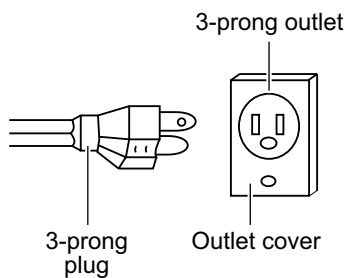

Using a 3-prong plug and outlet

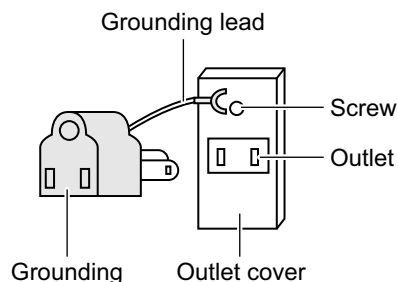

Using a grounding adapter

Using the freezer

The storage life of frozen foods varies. You should consume the food before the recommended storage time expires. Place frozen food into your freezer as quickly as possible after purchase. If there are instructions on the packaging, carefully follow these instructions regarding storage times.

Prepackaged, commercially-frozen food should be stored in accordance with the frozen food manufacturer's instructions for a three-star frozen food storage compartment or home freezer.

Shelves are provided for the organization of odd-shaped items.

Note: If the power fails, food in your freezer will stay frozen for several hours, even in summer. During a power failure, do not open the door more than you have to and do not add new food.

1. Plug in your freezer. Wait for 30 minutes, then open the freezer door to determine if your freezer is working correctly. When your freezer is plugged into a power outlet, it runs continuously.
2. Wait two to four hours before placing food into your freezer. If the room temperature is high, wait four or more hours.
3. Turn the Control knob to adjust the temperature. Your freezer has three marked temperature settings:
 - MIN: 10.4 °F ~ 5 °F (-12 °C ~ -15 °C)
 - MID: -0.4 °F ~ -4 °F (-18 °C ~ -20 °C)
 - MAX: -7.6 °F ~ -11.2 °F (-22 °C ~ -24 °C)

You can set the temperature to one of the setting positions or to a setting position between the marked settings.

Notes:

- You may need to adjust the temperature based on the room temperature. If the room temperature is high, (for example, in summer) lower the freezer temperature. If the room temperature is low, (for example, in winter) raise the freezer temperature.
- You may need to adjust the temperature based on how much food is in your freezer.
- If your freezer is unplugged or loses power, you must wait three to five minutes before restarting it. Your freezer will not start if you attempt to restart it sooner.
- If the power fails, unplug your freezer, then wait until the power is back to normal before you plug it in.
- Large amounts of food lower the cooling efficiency of your freezer.
- Do not put bottled food or drinks in your freezer.

Cleaning the freezer

Your freezer is designed for year-round use with only minimal cleaning and maintenance. We recommend that you do the following every time you clean it to keep your freezer running odor-free and efficiently:

⚠ CAUTION To prevent damage to the finish, do not use gasoline, benzene, thinner, or other solvents, and do not use abrasive cleaners. Caution To prevent damage to the finish, do not use gasoline, benzene, thinner, or other solvents, and do not use abrasive cleaners.

1. Unplug your freezer from the power outlet.
2. Remove all food from the appliance.
3. Wash the shelves with a mild detergent solution.
4. Wash the inside and outside with a cloth dampened with a non-corrosive, neutral detergent. If you use a detergent, remove the residual detergent with a cloth dampened with clear water. Do not use excessive detergent or water. Too much liquid may damage the electrical insulation.
5. Dry the inside and outside with a soft cloth or towel.
6. Make sure that you keep the door gasket (seal) clean so that the door seals tightly. This helps your freezer run efficiently.

Defrosting your freezer

Tip: To avoid standing water when you defrost, place some towels on the floor in front of your freezer.

1. Unplug your freezer.
2. Remove all food from your freezer, and place the food into containers that will prevent it from melting.
3. To speed the defrosting, you can:
 - Place a fan blowing on its highest speed right at the freezer. The ice will melt faster. After the ice melts, use towels to wipe up excess water, then use the fan to speed drying.
 - Place containers with hot water inside the freezer.
 - Use a plastic or wooden ice shovel (like a spatula) to remove thick layers of ice or frost. Do not use a sharp utensil (like a knife) because you may damage your freezer.
4. Use a cloth dampened with water or a mild cleaning solution to clean the inside of your freezer.
5. When you finish defrosting, wipe the inside with a dry towel.
6. Close your freezer, plug it into the power outlet, then put the food back into your freezer.

Storing your freezer

1. Unplug your freezer from the power outlet.
2. Remove all food.
3. Clean your freezer.
4. Take off the doors, and leave the shelves in place so that children may not easily climb inside.

⚠ CAUTION Use extreme caution with children. Make sure that children cannot access your freezer.

Moving your freezer

1. Unplug your freezer from the power outlet.
2. Remove all food from the appliance.
3. Securely tape down all loose items inside your freezer.
4. Tape the door shut.
5. Make sure that your freezer does not tilt more than 45° from the upright position during transportation.

Tips on saving energy

- Locate your freezer in the coolest area of the room, away from heat producing appliances or heating ducts and out of direct sunlight.
- Let hot foods cool to room temperature before placing them in your freezer. Overloading your freezer forces the compressor to run longer. Foods that freeze too slowly may lose quality or spoil.
- Wrap foods correctly and wipe containers dry before placing them in your freezer. This cuts down on frost build-up inside your freezer.
- Do not line the freezer storage shelves with aluminum foil, wax paper, or paper toweling. Liners interfere with cold air circulation and make your freezer less efficient.
- Organize and label food to reduce door openings and extended searches. Remove as many items as needed at one time, and close the door as soon as possible.

Troubleshooting Tips... Before you call for service

Problem	Possible solution
My freezer does not work.	<ul style="list-style-type: none"> ■ Make sure that your freezer is securely plugged into a working outlet. ■ Make sure that your power source has the correct voltage. Your freezer's voltage rate is on a label on the back of your freezer. ■ Check the house fuse or circuit breaker box and replace the fuse or reset the circuit breaker.
The freezer has a bad odor.	<ul style="list-style-type: none"> ■ Make sure that all food with a strong odor (like onions) is wrapped or stored in airtight packaging. ■ Certain containers and wrapping materials (such as paper, foil, or plastic) can cause odors. If you think this might be the case, try using different containers or a different brand of wrapping material. ■ Check for spoiled food and remove it. ■ Clean the inside of your freezer. See <i>Cleaning your freezer</i> on page 13.
The freezer door does not close completely.	<ul style="list-style-type: none"> ■ Make sure that no food packages are in the way. ■ Make sure that the door gasket (seal) is clean. See <i>Cleaning your freezer</i> on page 13. ■ If the door gasket does not seal, try heating then cooling the seal. You can use an electric hair dryer to heat the seal. ■ Make sure that your freezer is level. See <i>Leveling your freezer</i> on page 8.
The freezer door is hard to open.	<ul style="list-style-type: none"> ■ When you open the freezer door, warm air rushes inside. When you close the door, the warm air rushes to the condenser which causes a vacuum. This causes the door to be hard to open for about 10 to 15 seconds after closing. ■ If the door is hard to open at other times, try rubbing paraffin wax or petroleum jelly along the edges of the entire gasket. Paraffin wax is used for canning and is safe for use around food.
The compressor runs for a long time or turns on and off frequently.	<p>The compressor runs longer if:</p> <ul style="list-style-type: none"> ■ The room temperature is high. ■ You just added a large amount of food. Wait for the food to freeze, then check again. ■ You open and close the door frequently. ■ The door gasket is dirty. Clean the gasket. See <i>Cleaning your freezer</i> on page 13. ■ Your freezer has been disconnected for a period of time. Wait for your freezer to cool (about four hours) before adding food. ■ You have the temperature set too low. Set the Control knob to a higher temperature.
The light inside the freezer does not turn on.	<ul style="list-style-type: none"> ■ Make sure that your freezer is plugged into a working outlet. ■ Check to see if the light is damaged. If the light is damaged, have it replaced by a qualified service technician.
The freezer makes unusual noises or vibration.	<ul style="list-style-type: none"> ■ Metal parts expand and contract as the temperature changes. This is normal. ■ When the refrigerant is circulating throughout the system, your freezer may make noises. This is normal. ■ Remove items from the top of your freezer. ■ Make sure that your freezer is level. See <i>Leveling your freezer</i> on page 8. ■ If your freezer is touching walls, move it away from the walls. ■ Make sure that the shelves are installed correctly.

Troubleshooting Tips... Before you call for service

Problem	Possible solution
The water pan overflows.	<ul style="list-style-type: none"> ■ You have too much food in your freezer or stored food contains too much water which results in heavy defrosting. ■ The doors are not closed correctly, resulting in increased defrosting.
The outside of the freezer is hot.	<p>Heat dissipation from the condenser may make the outside feel hot. This is normal and happens if:</p> <ul style="list-style-type: none"> ■ The room temperature is high. ■ You have too much food in your freezer. ■ You open and close the door excessively.
Water condenses on the outside of the freezer.	<ul style="list-style-type: none"> ■ Condensation on the exterior surface and door seal is normal when the room humidity is high. ■ When you open the door, warm, moist outside air meets the cold dry air inside your freezer. These are normal. Just wipe off the condensation with a clean towel.

Please place in envelope and mail to:
Veuillez mettre dans une enveloppe et envoyez à:

**OWNERSHIP REGISTRATION
P.O. BOX 1780
MISSISSAUGA, ONTARIO
L4Y 4G1**

**(FOR CANADIAN CONSUMERS ONLY -
POUR RÉSIDENTS CANADIENS SEULEMENT)**



For Canadian
Customers



Pour les
Consommateurs
Canadiens

CUT ALONG THIS LINE AND RETURN CARD - THANKS
DÉCOUPEZ ICI ET ENVOYEZ LA FICHE - MERCI

OWNERSHIP REGISTRATION CERTIFICATE – FICHE D'INSCRIPTION DU PROPRIÉTAIRE

Please register your product to enable us to contact you in the remote event a safety notice is issued for this product and to allow for efficient communication under the terms of your warranty, should the need arise.

Veuillez enregistrer votre produit afin de nous permettre de communiquer avec vous si jamais un avis de sécurité concernant ce produit était émis et de communiquer facilement avec vous en vertu de votre garantie, si le besoin s'en fait sentir.

REGISTER ON-LINE: www.geappliances.ca

MAIL TO: **P.O. BOX 1780, MISSISSAUGA**

ENREGISTREMENT SUR INTERNET À : www.electromenagersge.ca

POSTEZ À : **ONTARIO, L4Y 4G1**

<input type="checkbox"/> MR. / M		<input type="checkbox"/> MRS. / MME.		FIRST NAME / PRÉNOM		LAST NAME / NOM	
<input type="checkbox"/> MISS/MLE.		<input type="checkbox"/> MS.					
STREET NO / N° RUE		STREET NAME / RUE				APT.NO/APP/RR#	
CITY / VILLE				PROVINCE		POSTAL CODE/CODE POSTAL	
AREA CODE/IND. RÉG.		TELEPHONE/TÉLÉPHONE		E-MAIL/COURRIEL			
DID YOU PURCHASE A SERVICE CONTRACT FOR THIS APPLIANCE? AVEZ-VOUS ACHETÉ UN CONTRAT DE SERVICE POUR CET APPAREIL?				YES/OUI <input type="checkbox"/> NO/NON <input type="checkbox"/>		IF YES/SI OUI : EXPIRATION Y/A M D/J	
NAME OF SELLING DEALER / NOM DU MARCHAND					MODEL / MODÈLE		
INSTALLATION DATE / DATE D'INSTALLATION Y/A M D/J			CORRESPONDENCE <input type="checkbox"/> ENGLISH CORRESPONDANCE <input type="checkbox"/> FRANÇAIS		SERIAL / SÉRIE		
<input type="checkbox"/> I do not wish to receive any promotional offers regarding this product. Je ne désire pas recevoir d'offres promotionnelles concernant ce produit.							

Moffat Appliances Freezer Warranty

WARRANTY

GEAppliances.ca

All warranty service is provided by our Factory Service Centers, or an authorized Customer Care® technician. To schedule service online, visit us at GEAppliances.ca/en/support/service-request/, or call GE Appliances at 800.561.3344. Please have your serial number and your model number available when calling for service.

Servicing your appliance may require the use of the onboard data port for diagnostics. This gives a GE Appliances factory service technician the ability to quickly diagnose any issues with your appliance and helps GE Appliances improve its products by providing GE Appliances with information on your appliance. If you do not want your appliance data to be sent to GE Appliances, please advise your technician not to submit the data to GE Appliances at the time of service.

For the period of	GE Appliances will replace
One year From the date of the original purchase	Any part of the dishwasher which fails due to a defect in materials or workmanship. During this limited one-year warranty , GE Appliances will provide, free of charge , all labor and in-home service to replace the defective part.

Staple your receipt here. Proof of the original purchase date is needed to obtain service under the warranty.

What GE Appliances will not cover (for customers in Canada):

- Service trips to your home to teach you how to use the product.
- Improper installation, delivery, or maintenance.
- Failure of the product if it is abused, misused or used for other than the intended purpose or used commercially.
- Replacement of house fuses or resetting of circuit breakers.
- Product not accessible to provide required service.
- Damage to the product caused by accident, fire, floods, or acts of God.
- Incidental or consequential damage caused by possible defects with this appliance.
- Cleaning or servicing of the air gap device in the drain line.
- Damage caused after delivery including damage from items dropped on the door.

This warranty is extended to the original purchaser and any succeeding owner for products purchased for home use within Canada. If the product is located in an area where service by a GE Appliances Authorized Servicer is not available, you may be responsible for a trip charge or you may be required to bring the product to an Authorized GE Appliances Service location for service.

EXCLUSION OF IMPLIED WARRANTIES

Your sole and exclusive remedy is product repair as provided in this Limited Warranty. Any implied warranties, including the implied warranties of merchantability or fitness for a particular purpose, are limited to one year or the shortest period allowed by law.

WARRANTOR IS NOT RESPONSIBLE FOR CONSEQUENTIAL DAMAGES.

Extended Warranties: Purchase a GE Appliances extended warranty and learn about special discounts that are available while your warranty is still in effect. Contact your retailer of purchase for more details.

Warrantor: MC Commercial Inc.

Consumer Support

GE Appliances Website

Have a question or need assistance with your appliance? Try the GE Appliances Website 24 hours a day, any day of the year! You can also shop for more great GE Appliances products and take advantage of all our on-line support services designed for your convenience. In Canada: **GEAppliances.ca**

Register Your Appliance

Register your new appliance on-line at your convenience! Timely product registration will allow for enhanced communication and prompt service under the terms of your warranty, should the need arise. You may also mail in the pre-printed registration card included in the packing material. In Canada: **GEAppliances.ca/en/support/register-your-appliance**

Schedule Service

Expert GE Appliances repair service is only one step away from your door. Get on-line and schedule your service at your convenience any day of the year. In Canada: **GEAppliances.ca/en/support/service-request** or call 800.561.3344 during normal business hours.

Extended Warranties

Contact your retailer of choice regarding extended warranties to purchase a GE Appliances extended warranty and learn about special discounts that are available while your warranty is still in effect.

Parts and Accessories

Individuals qualified to service their own appliances can have parts or accessories sent directly to their homes via their local parts distributor. Or, call 800.661.1616 during normal business hours.

Instructions contained in this manual cover procedures to be performed by any user. Other servicing generally should be referred to qualified service personnel. Caution must be exercised, since improper servicing may cause unsafe operation.

Contact Us

If you are not satisfied with the service you receive from GE Appliances, contact us on our Website with all the details including your phone number, or write to:

Director, Customer Relations | MC Commercial Inc. | Suite 310 - 1 Factory Lane, Moncton NB, E1C 9M3