

## 5.0 Cubic Foot Chest Freezer

HF50CM23NW



Available

### Unit Specifications

Width	28 3/8"
Depth	21 5/8"
Height	33 1/4"
Weight	79 lbs.
UPC	688057211510

### More Easy-To-Use Features

- Holds up to 175lbs of frozen food
- Adjustable thermostat control
- Easy-Access Defrost Drain
- Space-Saving Flat-Back Design
- Manual Defrost
- Removable Basket

### Warranty

- 1 Year Warranty (Parts and Labor)
- 5 Year Sealed System

### Available Finishes



White

### Signature Features

#### Storage for up to 175 lbs

Storage space to accommodate all your frozen food needs

#### Removable Basket

Allows flexibility when arranging items

#### Easy Access Defrost Drain

Front drain makes defrosting quick and effortless

#### Adjustable Thermostat

Ensures accurate storage temperatures at the turn of a dial

Letter	Cutout Dimension	in.
A	Height	28 3/8"
B	Depth	21 5/8"
C	Width	33 1/4"

Clearances	
Back	4"
Sides	4"
Top	Do not block

Power Requirements	
Electrical Rating	115V, 60Hz
Energy Use	216kWh
Refrigerant	R600a

Overall Packaging Details		
Packaging	lb./in.	
Gross Weight	79 lb.	
Dimensions	<b>W</b>	30 1/2"
	<b>D</b>	23 1/16"
	<b>H</b>	35 1/16"

### Product Technical Illustration

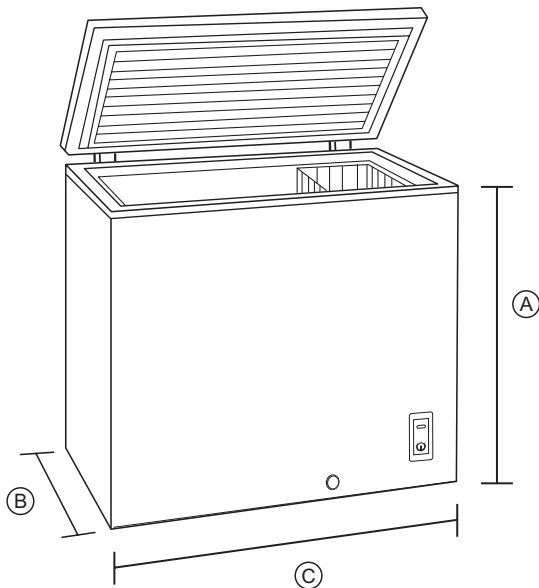

### General Appliance Information

Please read all installation details and instructions before use.

### Contact Us

For questions regarding this product please refer to our website at [haieramerica.com](http://haieramerica.com) or call our customer service center at 877-337-3639.

