

30" COMBINATION MICROWAVE/WALL OVENS

JMW2430I, JMW3430I – 30" x 43-3/4" x 25-5/16"

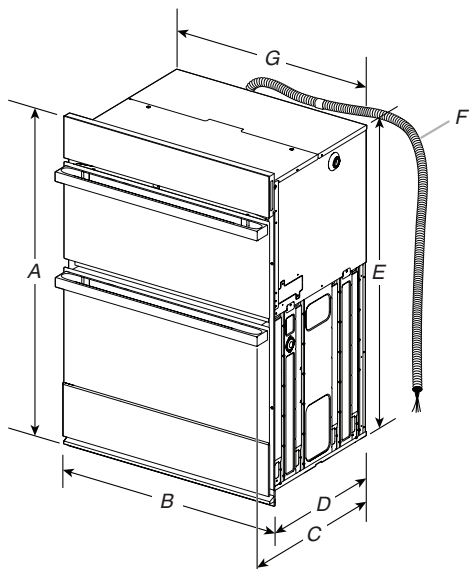

PRODUCT DIMENSIONS

30" (76.2 CM) MODELS

- A. 43-3/4" (111 cm) overall height
- B. 30" (76.2 cm) overall width
- C. JMW2430IM – 26-3/8" (67 cm)
JMW2430IL – 27-3/16" (69 cm)
JMW3430IM – 26-3/8" (67 cm)
JMW3430IL – 27-3/16" (69 cm)
- D. 23-1/4" (59.1 cm) max. recessed depth
- E. 41" (104.1 cm) recessed height
- F. 48" (121.9 cm) flexible conduit length measured from the conduit clamp located at the rear of the oven. Do not remove the conduit clamp.
- G. 28-7/16" (72.2 cm) recessed width

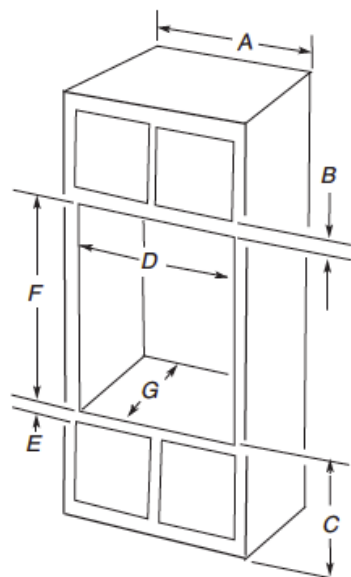

OPENING/CLEARANCE DIMENSIONS

30" (76.2 CM) MODELS

- A. 30" (76.2 cm) min. cabinet width
- B. 2-1/4" (5.7 cm) top of cutout to bottom of upper cabinet door
- C. 19-1/4" (48.9 cm) bottom of cutout to floor is recommended.
4"-19-1/4" (10.2-48.9 cm) bottom of cutout to floor is acceptable.
- D. 28-1/2" (72.4 cm) cutout width
- E. 1-1/2" (3.8 cm) min. bottom of cutout to top of cabinet door
- F. 41-5/16" (105 cm)* recommended cutout height
- G. 24" (60.7 cm) cutout depth

*NOTE: The cutout height can be between 41" and 41-1/2" (104.1 cm and 105.6 cm) for microwave/oven combination.

IMPORTANT: Dimensional specifications are provided for planning purposes only. Do not make any cutouts based on this information. Refer to the Installation or Use & Care Guide before selecting cabinetry, verifying electrical/gas connections, making cutouts or beginning installation. All JennAir® appliances are appropriately UL, CUL or CSA approved.



30" COMBINATION MICROWAVE/WALL OVENS

JMW2430I, JMW3430I – 30" x 43-3/4" x 25-5/16"

ELECTRICAL REQUIREMENTS

If codes permit and a separate ground wire is used, it is recommended that a qualified electrical installer determine that the ground path and the wire gauge are in accordance with local codes.

Check with a qualified electrical installer if you are not sure the oven is properly grounded.

This oven must be connected to a grounded metal, permanent wiring system.

Be sure that the electrical connection and wire size are adequate and in conformance with the National Electrical Code, ANSI/NFPA 70-latest edition or CSA Standards C22.1-94, Canadian Electrical Code, Part 1 and C22.2 No. O-M91-latest edition, and all local codes and ordinances.

A copy of the above code standards can be obtained from:

National Fire Protection Association
1 Batterymarch Park
Quincy, MA 02169-7471

CSA International
8501 East Pleasant Valley Road
Cleveland, OH 44131-5575

- Models rated from 7.3 to 9.6 kW at 240 V (5.4 to 7.4 kW at A. Model/Serial/Rating Plate 208 V) require a separate 40 A circuit.
- A circuit breaker is recommended.
- Connect directly to the fused disconnect (or circuit breaker box) through flexible, armored or nonmetallic sheathed, copper cable (with grounding wire).
- Flexible conduit from the oven should be connected directly to the junction box.
- Do not cut the conduit. The length of conduit provided is for serviceability of the oven.
- A UL listed or CSA approved conduit connector must be provided.
- If the house has aluminum wiring, follow the procedure below: Connect the aluminum wiring using special connectors and/or tools designed and UL listed for joining copper to aluminum. Follow the electrical connector manufacturer’s recommended procedure. Aluminum/copper connection must conform with local codes and industry-accepted wiring practices.

For power requirements, refer to the following table:

	240 VAC	208 VAC
Model	kW	kW
JMW2430I	8.0	6.6
JMW3430I	8.2	6.6

ELECTRICAL CONNECTION

To properly install your oven, you must determine the type of electrical connection you will be using and follow the instructions provided for it here.

- Oven must be connected to the proper electrical voltage, amperage and frequency as specified on the model/serial/rating plate. See the following illustration.

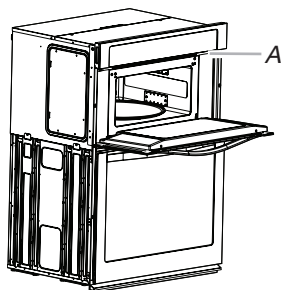

A. Model/Serial/Rating Plate

IMPORTANT: Dimensional specifications are provided for planning purposes only. Do not make any cutouts based on this information. Refer to the Installation or Use & Care Guide before selecting cabinetry, verifying electrical/gas connections, making cutouts or beginning installation. All JennAir® appliances are appropriately UL, CUL or CSA approved.

