

INSTALLATION MANUAL

CONVERTIBLE GAS GRILL COOKTOP SERIES JGD8130 & JGD8345

JENN-AIR

403 WEST FOURTH STREET, NORTH • NEWTON, IA 50208

DIMENSIONS SHOWN IN BOTH INCHES AND CENTIMETERS

*Blower may be rotated for horizontal or vertical direction by loosening nuts around blower inlet. Accessible inside ventilation chamber.

- **NOTICE TO INSTALLER:** Leave these instructions with the appliance.
- **NOTICE TO CONSUMER:** Retain these instructions for future reference.

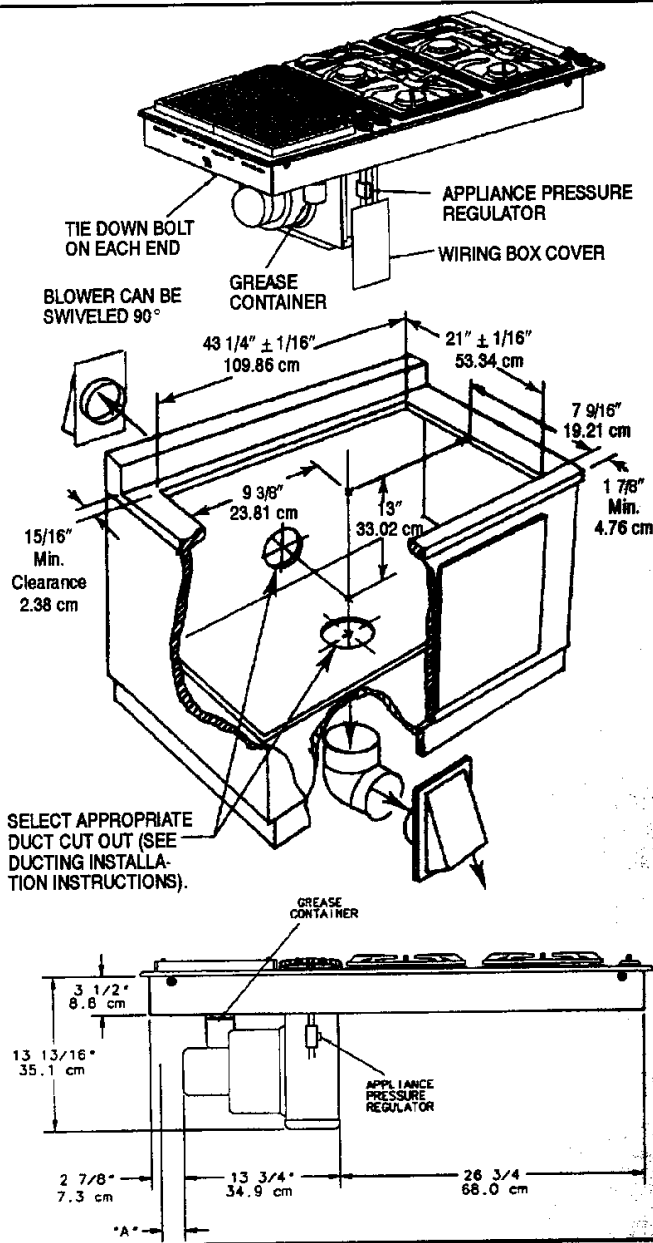
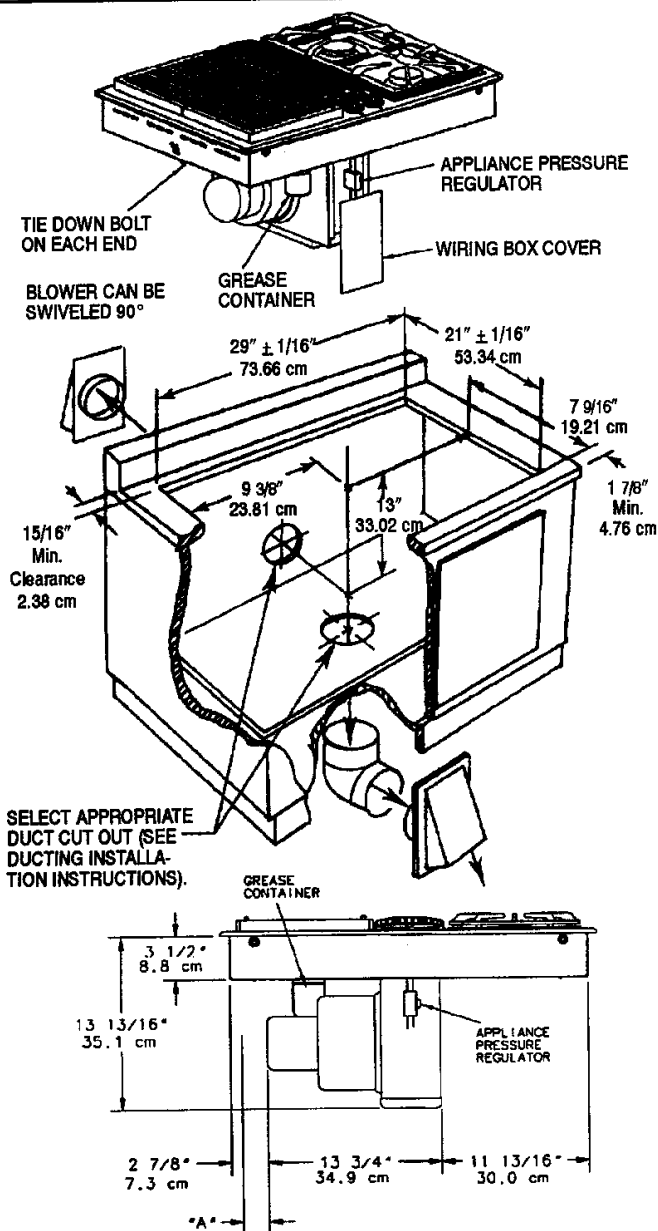

INSTRUCTIONS TO INSTALLER

- Dimension "A" - Provide 2" min. (5.08 cm) cabinet clearance to motor for cooling purpose.
- **Note** - Where possible, 6" (15.24 cm) is recommended for motor/blower service.
- Side Clearance - Grills installed near a side wall must allow a minimum clearance of 8".
- Access must be provided to remove and empty grease container(s).



8101P406-60
(09-01-00)

Installing Cabinetry Over Your Jenn-Air Grill

*A = 30" (76.2 cm) minimum vertical clearance between cooking surface and construction above the appliance.

*B = 13" (33.02 cm) maximum depth of cabinets installed above cooking top.

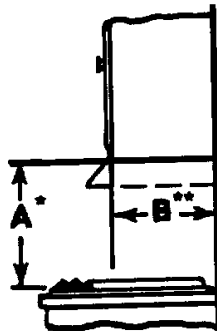

Dotted lines indicate range hood construction

* To eliminate associated potential hazards such as reaching over open flames, avoid use of cabinets above cooktop for storage space.

Cabinets Above Cooking Top

Maximum depth of cabinets installed above cooking top is 13 inches.

CAUTION: SOME CABINETS AND BUILDING MATERIALS ARE NOT DESIGNED TO WITHSTAND THE HEAT PRODUCED BY THE NORMAL SAFE OPERATION OF A LISTED APPLIANCE. DISCOLORATION OR DAMAGE, SUCH AS DELAMINATION, MAY OCCUR.

Installation Of Appliance

Follow accompanying ducting instructions carefully.

This appliance is designed to always be vented outdoors.

The Countertop Cutout, Cabinet Front Cutout and Duct Opening should be prepared according to the illustration on pages 1 and 2.

The installation of this appliance must conform with local codes or, in the absence of local codes, with the latest edition of the National Fuel Gas Code, ANSI Z223.1 USA or current CAN/CGA-B149 INSTALLATION CODE.

The electrical supply required is 110/120 Volt, A.C., 15 amp, 60 Hz. This appliance is equipped with a grounded type power cord. A grounded outlet must be provided. It is recommended, for convenience, this outlet be located in the area shown in the shaded illustration (see figure 2).

This appliance, when installed, must be electrically grounded in accordance with local codes or, in the absence

of local codes, with the latest edition of the National Electrical Code ANSI/NFPA No. 70 USA or current CSA STANDARD C22.1 Canadian Electrical Code part 1.

CAUTION

Warranty is void on JENN-AIR equipment installed other than as recommended by manufacturer. Recommended wall caps and transitions must be utilized for proper operation and installation.

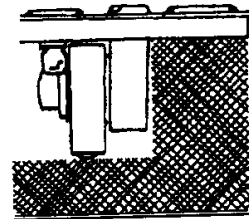

Cabinet Bottom

Figure 2

WARNING

ELECTRICAL GROUNDING INSTRUCTIONS

THIS APPLIANCE IS EQUIPPED WITH A THREE-PRONG GROUNDING PLUG FOR YOUR PROTECTION AGAINST SHOCK HAZARD AND SHOULD BE PLUGGED DIRECTLY INTO A PROPERLY GROUNDED RECEPTACLE. DO NOT CUT OR REMOVE THE GROUNDING PRONG FROM THIS PLUG.

Connecting Appliance To Gas Supply

A TRAINED SERVICEMAN OR GAS APPLIANCE INSTALLER MUST MAKE THE GAS SUPPLY CONNECTION. Leak testing of the appliance shall be conducted by the installer according to the instructions given.

Install a manual shutoff valve in an accessible location in the gas line external to this appliance for the purpose of turning on or shutting off gas to the appliance.

Make the gas connection to the inlet to the appliance pressure regulator on this appliance with a 1/2" male pipe thread. Use an approved pipe joint compound resistant to the action of LP gas at pipe connections. Test all joints for gas leaks with a soap and water solution or other accepted leak detection means. Never test for gas leaks with an open flame.

Instructions To Installer

1. Chamfer all exposed edges of decorative laminate to prevent damage from chipping.
2. **Radius corners of cutout and file to insure smooth edges and prevent corner cracking. Recommend 1/4" or 3/8" diameter drill in each corner.**
3. Rough edges, inside corners which have not been rounded and forced fit can contribute to cracking of the counter top laminate.
4. Countertop must be supported within 3" of cutout.

Minimum horizontal clearance between the edge of the appliance and combustible construction extending from the cooking surface to 18" (45.7 cm) above the cooking surface is:

15/16" (2.38 cm) at rear
8" at sides

This is not the recommended clearance, but minimum allowable clearance.

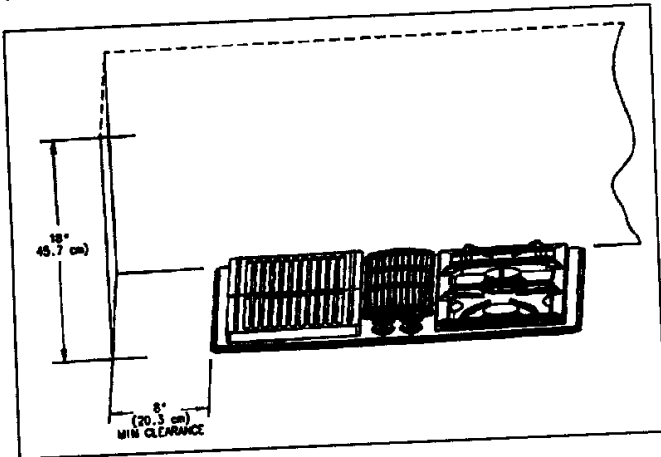

Air Shutter Adjustment

This appliance is shipped from the factory with air shutters adjusted for use with Natural Gas. If further adjustment is necessary, or to reset for use with LP, adjust air shutters as follows:

Grill Burner and Surface Burner Cartridge Air Shutters (See Illustrations "A" & "B")

The left hand air shutter controls the rear half of the burner. The right hand shutter controls the front half. Access to air shutters on the surface burner cartridge may be found through openings on the bottom of the cartridge housing.

Slide air shutters backward or forward to increase or decrease the size of the air opening. Air shutters fit snugly, so a screwdriver blade may be required to make this adjustment (see illustration).

Observe change in flame appearance as the air shutter is moved. Adjustment is satisfactory when a clearly defined, even blue flame results at the high flame setting. The snug fit of the air shutter assures it will remain positioned correctly.

Grill Burner Air Shutter and Surface Burner (if so equipped)

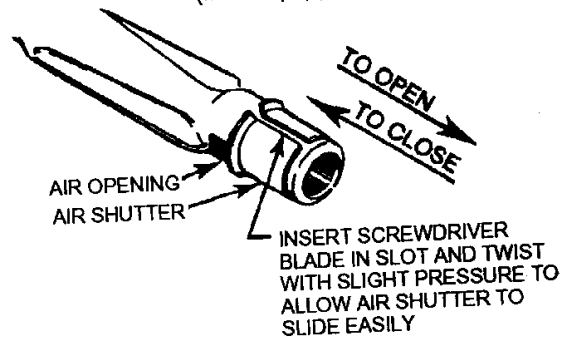

ILLUSTRATION "A"

On any burner, closing the air shutter too far will cause the flame to become soft and yellow tipped. Opening the air shutter too wide will cause the flame to blow away from the burner ports. Proper adjustment will produce a sharp, clearly defined, even blue flame.

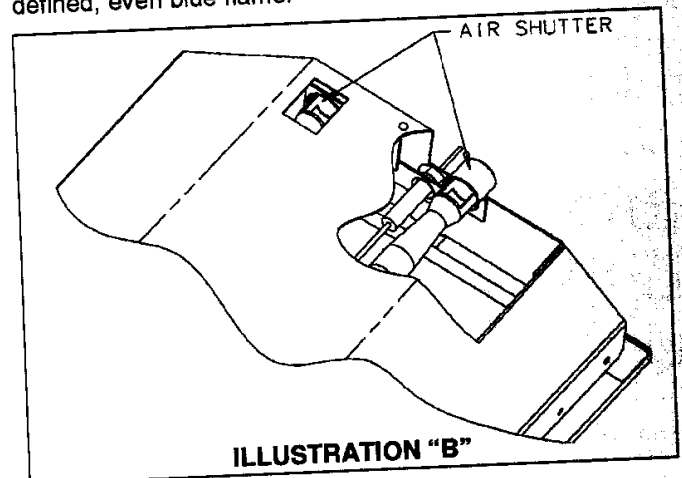

ILLUSTRATION "B"

Low Flame Adjustment (See Illustration "C")

This appliance is shipped from the factory with low and medium flame settings adjusted for use with Natural Gas. If further adjustment is necessary, or to readjust for use with LP, proceed as follows:

1. Light burner and set control knob for low flame.
2. Remove control knob from valve stem.

CAUTION

NEVER USE A METAL BLADE TO PRY KNOB OFF. IF KNOB CANNOT BE EASILY REMOVED, TUCK THE FOLDS OF A CLOTH DISHTOWEL UNDER THE KNOB AND PULL THE TOWEL UPWARD WITH STEADY, EVEN PRESSURE.

3. Insert a slender, thin-blade screwdriver into the recess at center of valve stem and engage blade with slot in adjusting screw.
4. Turn center stem adjusting screw to set flame size.
 - clockwise to reduce.
 - counterclockwise to increase.
5. Replace control knob when adjustment is completed.

Proper adjustment will produce a stable, steady blue flame of minimum size. The final adjustment should be checked by turning knob from high to low several times without extinguishing the flame.

This adjustment, at low setting, will automatically provide the proper flame size at medium setting.

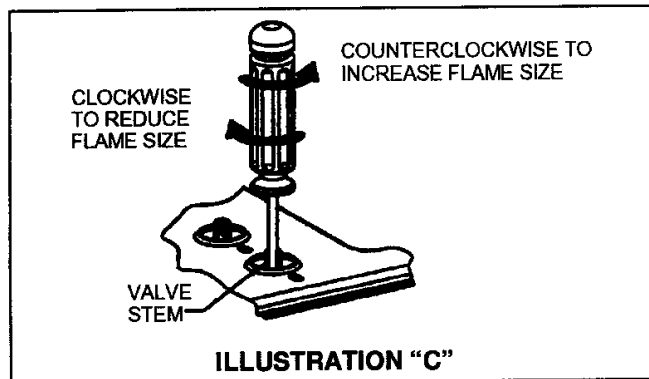

Pressure Testing

The maximum gas supply pressure for the appliance pressure regulator supplied on this appliance is 14" W.C. The test pressure for checking this appliance pressure regulator must be at least 6" W.C. for Natural Gas, and at least 11" W.C. for LP. It is shipped from the factory set for Natural Gas at 5" W.C. output pressure.

This appliance and its individual shutoff valve must be disconnected from the gas supply piping system during any pressure testing of that system at test pressures in excess of 1/2" PSIG (3.5 k Pa).

This appliance must be isolated from the gas supply piping system by closing its individual manual shutoff valve during any pressure testing of the gas supply piping system at test pressures equal to or less than 1/2" PSIG (3.5 k Pa).

Appliance Pressure Regulator Conversion (See Illustration "D")

This unit is supplied with a Maxitrol Appliance Pressure Regulator. Follow the instructions in illustration "D".

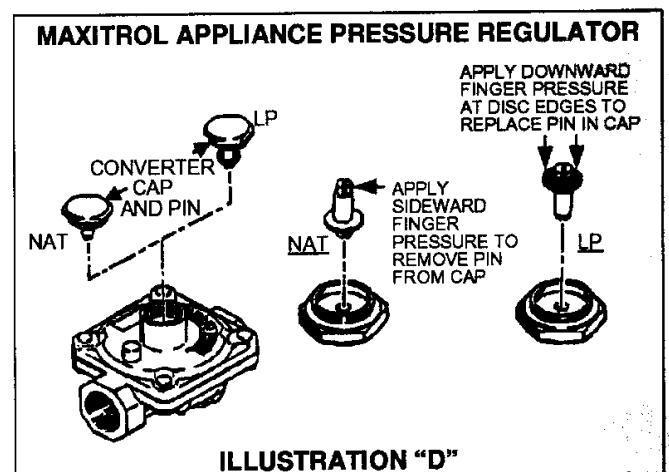

Conversion To LP Gas

This appliance is shipped from the factory equipped for use with Natural Gas. To convert it from Natural Gas for use with LP Gas, perform steps 1 through 4.

1. Remove natural gas orifice hoods. Install color coded orifice hoods supplied, located in a pack attached to the outer plenum area of this appliance. (See Illustration "E" below, and LP Gas Conversion Instructions on page 6).
2. Invert cap in convertible appliance pressure regulator (if so equipped) located at entrance to gas manifold.
3. Adjust air shutters on individual burners for proper flame appearance.
4. Adjust low flame setting at each burner by turning adjustment screw in center of valve stem.

To make these conversion adjustments follow the instructions and illustrations ("A" through "E" on pages 3 - 4).

IMPORTANT

Apply a non-corrosive leak detection fluid to all joints and fittings in the gas connection between the supply line shut-off valve and the range. Include gas fittings and joints in the range if connections were disturbed during installation. Check for leaks! Bubbles appearing around fittings and connections will indicate a leak. If a leak appears, turn off supply line gas shut-off valve and retest for leaks. Never test for gas leaks with an open flame.

This appliance is shipped from the factory with orifice hoods drilled for use with Natural Gas. To convert from Natural Gas to LP, apply a 1/2" open-end wrench to hex section of orifice hood. TURN COUNTERCLOCKWISE TO REMOVE. Save the Natural Gas orifice hoods just removed from this appliance for future use. Install color coded orifice hoods supplied. (See LP Gas Conversion Instructions above and page 6). TURN CLOCKWISE TO INSTALL. Hold dimension specified in Illustration "E".

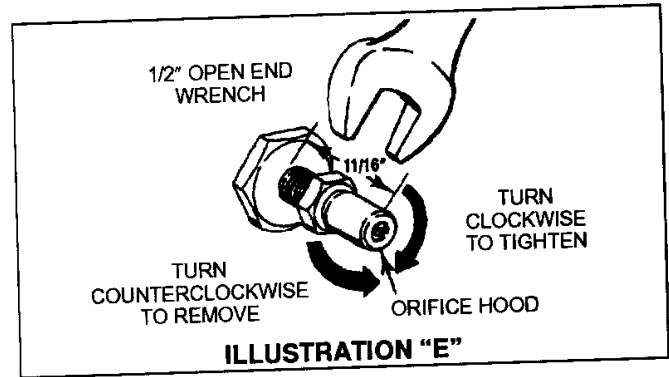

Control Settings

The size and type of cookware and the amount and type of food being cooked will influence the setting needed for best cooking results. The setting indicated should serve as a guide while you become familiar with your cooktop.

Use the **Hi** flame setting to quickly bring foods to a boil or to begin a cooking operation. Then reduce to a lower setting to continue cooking. *Never leave food unattended over a HI flame setting.*

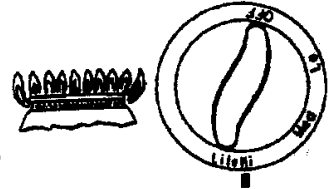

Med setting is used to continue a cooking operation. Food will not cook any faster when a **HI** flame setting is used than that is needed to maintain a gentle boil. Remember, water boils at the same temperature whether boiling gently or vigorously.

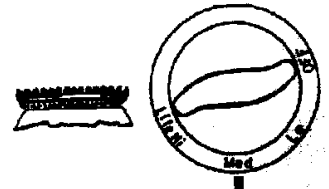

Use **Lo** setting to keep food at serving temperatures without further cooking. You may find that some cooking may take place if the cookware is covered.

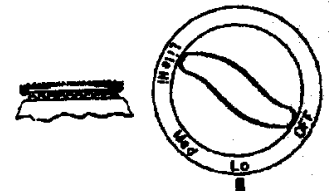

Minimum Spacing Requirement Convertible Gas Cooktops

For installing a Double Bay Downdraft Cooktop in combination with another Downdraft Cooktop, the minimum spacing between adjacent units must be provided, as shown, for satisfactory performance.

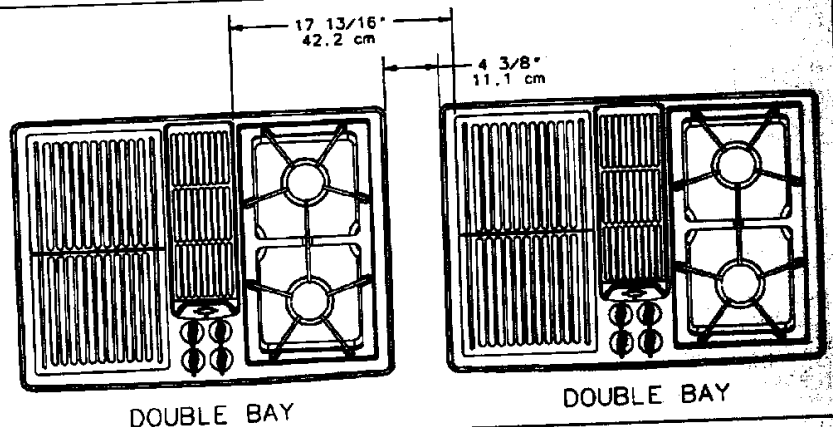

TO CONVERT APPLIANCE FOR USE WITH PROPANE GAS

Natural Gas To Propane Gas (LP) Conversion Instructions

⚠ WARNING

Propane Gas conversion is to be performed by a Jenn-Air Authorized Service Contractor (or other qualified agency) in accordance with the manufacturer's instructions and all codes and requirements of the authority having jurisdiction. Failure to follow instructions could result in serious injury or property damage. The qualified agency performing this work assumes responsibility for this conversion.

⚠ WARNING

ELECTRICAL POWER AND GAS MUST BE TURNED OFF PRIOR TO CONVERSION

Models - JGD8130 & JGD8345 Series

Manifold - Propane Gas pressure required - 10" W.C.

Incoming Propane Gas pressure required to appliance pressure regulator - 11" - 12" W.C.

Propane Gas conversion orifice hoods are supplied with these models.

Propane Gas input specified - JGD8130/JGD8345 - 33,000 BTU/hr / 51,000 BTU/hr.

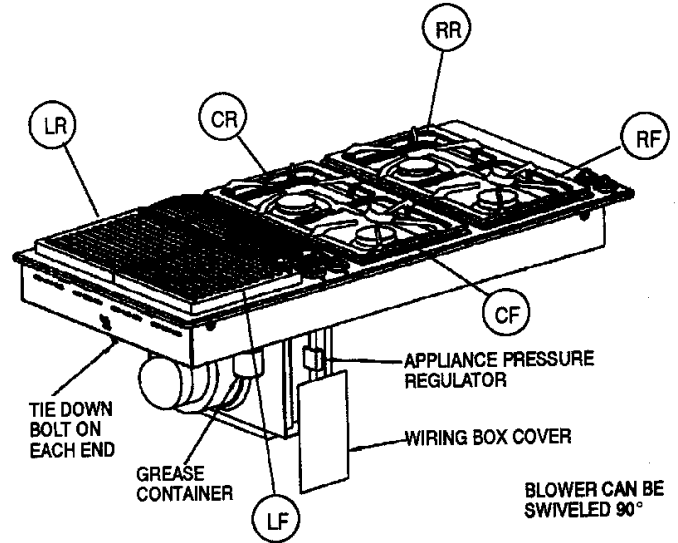

JGD8345 (Shown)

BURNER	BTU/hr	ORIFICE	INCHES DIAMETER	COLOR
Left Rear (LR)	7,500	#66	.0330	Zinc
Left Front (LF)	7,500	#66	.0330	Zinc
Right Rear (RR)	9,000	#63	.0310	Blue
Right Front (RF)	9,000	#63	.0370	Blue
Center Rear (CR)	9,000	#63	.0370	Blue
Center Front (CF)	9,000	#63	.0370	Blue

TO CONVERT APPLIANCE FOR USE WITH NATURAL GAS

Propane Gas (LP) To Natural Gas Conversion Instructions

If this appliance has been converted for use with LP Gas, each of the following modifications must be performed to convert the unit back to Natural Gas.

⚠ WARNING

Natural Gas conversion is to be performed by a Jenn-Air Authorized Service Contractor (or other qualified agency) in accordance with the manufacturer's instructions and all codes and requirements of the authority having jurisdiction. Failure to follow instructions could result in serious injury or property damage. The qualified agency performing this work assumes responsibility for this conversion.

⚠ WARNING

ELECTRICAL POWER AND GAS MUST BE TURNED OFF PRIOR TO CONVERSION

Models - JGD8130 & JGD8345 Series

Manifold - Natural Gas pressure required - 5" W.C.

Incoming Natural Gas pressure required to appliance pressure regulator - 6" - 7" W.C.

Natural Gas input specified, Model JGD8130/JGD8345 - 36,000 BTU/hr / 56,000 BTU/hr.

- A. Replace all orifice hoods - Perform steps 1 through 4 on page 4. Locate the (4) four or (2) two Natural Gas hoods (with small numbers stamped on their sides) saved from the original Natural Gas unit. Page 4 Illustration "E". The two hoods with .0520 (#55 orifice) stamped on them are for the left front and left rear burners. The two hoods with the .0550 (#54 orifice) stamped on them are for the two right burners.

To make these conversion adjustments follow the instructions and illustrations ("A" through "E") pages 3 and 4.

- B. Invert cap in appliance pressure regulator (see Illustration "D"). With the appliance installed, the appliance pressure regulator is located on the center underside of the appliance at the inlet to the gas manifold. Identify the type of appliance pressure regulator on the unit and follow the instructions in the appropriate illustration.
- C. Adjust low flame setting for each burner. Follow the instructions for burner low flame adjustment on page 4 to increase the simmer flame size.

JGD8345 (Shown)

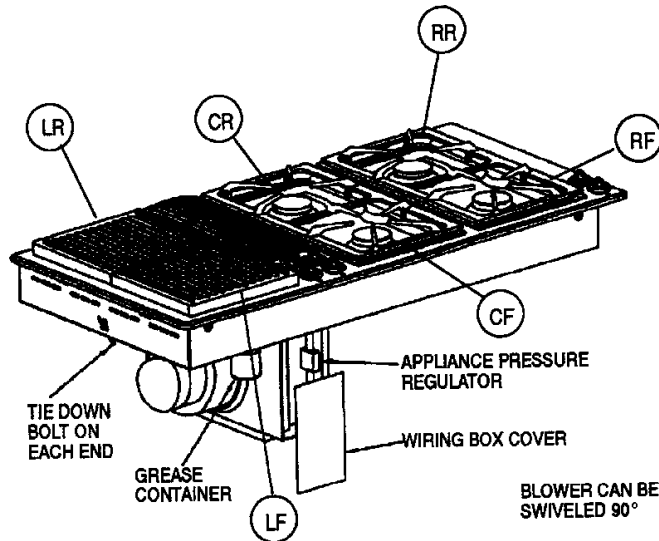

BURNER	BTU/hr	ORIFICE	INCHES DIAMETER	COLOR
Left Rear (LR)	8,000	#55	.0520	Brass
Left Front (LF)	8,000	#55	.0520	Brass
Right Rear (RR)	10,000	#54	.0550	Brass
Right Front (RF)	10,000	#54	.0550	Brass
Center Rear (CR)	10,000	#54	.0550	Brass
Center Front (CF)	10,000	#54	.0550	Brass

REQUIRED ADJUSTMENTS AT TIME OF INSTALLATION

The installation of this appliance must conform with local codes, or in the absence of local codes, with the latest edition of the National Fuel Gas Code ANSI Z223.1 USA or current CAN/CGA-B149 Installation Code.

- This range was manufactured for use with Natural Gas. If LP gas is the fuel of choice, follow the conversion to LP procedure found in the installation instructions.
- Test all external connections for gas leaks. Never test for gas leaks with an open flame.
- Test all electrical connections.
- Adjust all air shutters for proper flame.
- Adjust all valves for low flame settings.
- Test the ventilation system for proper installation.
- If a problem exists with the downdraft system, check the ducting installation to make sure it conforms to the Jenn-Air specifications. Most downdraft system problems are attributed to poor ducting practices.
- Contact your installer if the ventilation system will not remove smoke or cooking fumes from well trimmed cuts of meat.
- If ventilation problems persist contact your authorized Jenn-Air Service Contractor.



403 WEST FOURTH STREET, NORTH • NEWTON, IA 50208