



1.5 cu. ft. Countertop Microwave

KMCC5015G



Stainless Steel
KMCC5015GSS

Capacity

Total 1.5 cu. ft.

General Features & Properties

6 Quick-Touch Cycles Including Five Sensor Cycles

13 1/2" Recessed Turntable

1.5 Cu. Ft. Capacity

Accepts 30- or 27-Inch Trim Kit

Electronic Controls with LED Display

Color-Coordinated Stainless Steel Cabinet

Electrical Details

Amps 15

Volts 120

Technical Details

Microwave Type Countertop

Lighting Type Incandescent

Dimensions

Product Dimensions (H x W x D)
12-1/2" x
21-3/4" x
20-1/2"

Reference Material

[Dimension Guide](#)

[Install Guide](#)

[Use & Care Guide](#)

[Warranty](#)

Key Features & Benefits

1400-Watt Convection Element

Circulates heat around the back of the oven to allow convection baking at temperatures up to 425°F.

Roast Function

Helps maintain the balanced heat distribution required for exceptional roasting by alternating traditional microwave cooking with convection cooking to evenly surround food with heat.

Grill Function

Delivers grilling results similar to a conventional oven. A rack that comes with the microwave heats during the grilling process to sear meats and lock in flavor.

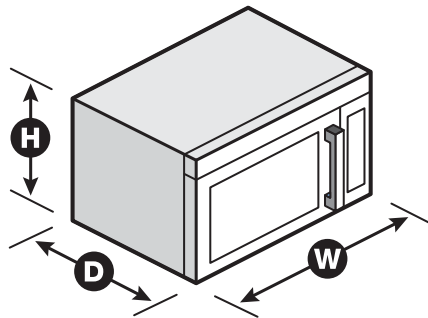

NOTE: Dimensions are for planning purposes only. For complete details, see Installation Instructions packed with product. Specifications subject to change without notice.

®/™ © 2020. All rights reserved. Printed in the U.S.A. D200104XXE. KMCC5015GSpecSheetV01.