



## K540E-A-NV

KORAL Dishwasher, with the Ecoclean Control system to guarantee the partial refill of water at every wash cycle, is the ideal solution in terms of efficacy, hygiene, saving, and respect for the environment.

### TECHNICAL FEATURES

- Evolute Electronic control with Uniko touch screen display
- Choice of 4 programs with 15 individual programmable portions of each cycle
- Built in Drain pump with Ecoclean system for partial refilling of clean water every washing cycle
- ETL Sanitation (NSF equivalent) to guarantee a sanitizing wash and a high rinse temperature.
- Adjustable 3 Lt/h detergent dispenser - Adjustable 0,3 Lt/h rinse-aid dispenser
- Uses standard 20"x 20" (500 x 500 mm) baskets
- Baskets supplied: 1 dish basket, 1 glass basket, 2 cutlery baskets
- Wash pump: 3/4 HP
- Electric power wire supplied without end terminals to make installation easier
- Tank: heating element: 2.6 kW, capacity: 5.3 G (24 Lt)
- Booster: heating element: 2.5 kW, capacity: 1.9 G (7.3 Lt)
- Door Height clearance: 15" (383 mm), Soft opening and closing
- Stainless steel detergent injector welded to tank
- Vacuum breaker valve
- Adjustable rotation speed of Stainless Steel rinse arms
- Integral Stainless Steel tank filter + New filtering group for suction and drain
- Low maintenance, heavy duty, 304 Stainless Steel.
- Warranty 2 years parts. 1 year labor
- Power requirements: 3.12 kW, 208/220 V, 50/60 Hz, 16 A, 1PH
- Hot water requirements: ½ GPC (2.6 LPC) 125°F (55°C) (will operate with cold water at reduced capacity)
- Water line requirements: ¾" (or ½" with ¾" NPT terminal) (hose supplied)
- Water pressure requirements 30 – 60 psi (2 – 4 bar)
- Drain line: 1" (25 mm) (connection hose supplied)
- Dimensions: 23W x 23 ¾ D x 31 ¾ H. (585 W x 600 D x 810 H mm)
- Shipping size: 26 ¾ x 31 ½ x 39 ½ H. (680 W x 800 D x 1000 H mm)
- Shipping weight: 153 lbs. (69.2 kg), Net weight 126 lbs (57.5 kg)



Intertek



Intertek

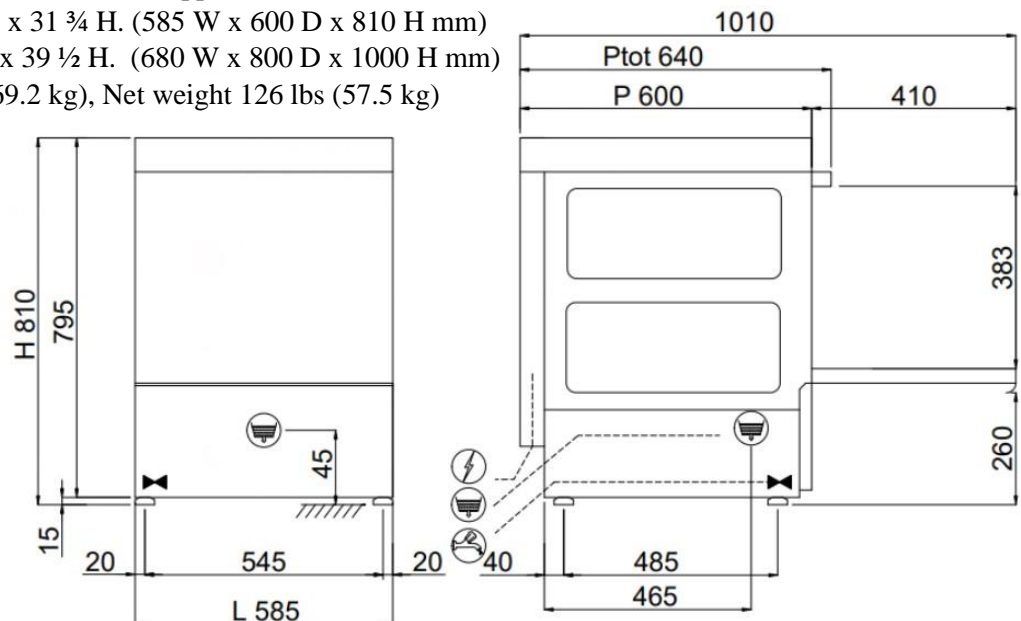

Data is indicative. In the event of further development, we reserve the right to alter our design and/or specification without notice.