

## WashTower™ with Center Control®

- Single Unit WashTower™ Design with Center Control
- 5.0 cu. ft. Washer / 7.4 cu. ft. Dryer
- TurboWash® 360° Wash Technology
- TurboSteam® Dryer
- SteamFresh™ Dryer Cycle
- AI DD® 2.0 Built-in Intelligence / AI Fabric Sensors, Smart Pairing™
- 12 (+14) Wash Cycles / 18 Wash Options
- 12 (+13) Dry Cycles / 14 Dry Options
- Allergiene® Cycle
- Direct Drive Motor (10-Year Limited Warranty)
- NeveRust™ Stainless Steel Drum (Washer & Dryer)
- LG ThinQ® Technology (Wi-Fi)



### COLOR AVAILABILITY

- WKEX300HBA (Electric Dryer) – Black Steel
- WKGX301HBA (Gas Dryer) – Black Steel

### CAPACITY

|                           |     |
|---------------------------|-----|
| Washer Capacity (cu. ft.) | 5.0 |
| Dryer Capacity (cu. ft.)  | 7.4 |

### APPEARANCE

|                                      |     |
|--------------------------------------|-----|
| Center Control®                      | Yes |
| Electronic Controls with LCD Display | Yes |
| Touch Buttons                        | Yes |

### ENERGY & WATER

|  |                             |
|--|-----------------------------|
| ENERGY STAR® Certified                   | Yes                         |
| CEE Qualified                            | Advanced Tier               |
| Integrated Modified Energy Factor (IMEF) | 3.1                         |
| Integrated Water Factor (IWF)            | 2.9                         |
| CEF                                      | Electric: 3.94<br>Gas: 3.49 |

### WASH CYCLES

|                  |  |
|------------------|--|
| Number of Cycles | 12 (+14)   |
| Wash Cycles      | Normal, AI Wash, Bedding, Delicates, Towels, Quick Wash, Heavy Duty, Allergiene®, Perm. Press, Tub Clean, Bright Whites™, Sanitary |

### WASH OPTIONS

|                   |  |
|-------------------|--|
| Number of Options | 18   |
| Options           | TurboWash®, Steam, Extra Rinse, Prewash, Drum Light, Control Lock, Signal, Wi-Fi / Remote Start, ezDispense™, Cold Wash, Fresh Care, Delay Wash, Cycle List Edit, ezDispense™ Nozzle Clean, Smart Diagnosis, Cycle Optimization, Brightness, Factory Reset |

### WASH DETAILS

|                            |   |
|----------------------------|---|
| Internal Heater            | Yes                                     |
| Number of Wash/Rinse Temps | 5                                       |
| Wash/Rinse Temps           | Hot, Very Warm, Warm, Cool, Cold        |
| Number of Spin Speeds      | 5                                       |
| Spin Speeds                | High, Medium/High, Medium, Low, No Spin |
| Max RPM                    | 1,300                                   |
| Water Levels               | Load Sensing                            |
| Number of Soil Levels      | 5                                       |
| AAFA Certified             | Yes                                     |

### DRYER CYCLES

|                   |   |
|-------------------|---|
| Number of Cycles  | 12 (+13)  |
| Sensor Dry Cycles | Normal, AI Dry, Bedding, Delicates, Towels, Quick Dry, Timed Dry, Power Dry, Perm. Press, Steam Fresh™, Heavy Duty, Air Dry |

## DRYER OPTIONS

|                      |   |
|----------------------|---|
| Number of Options    | 14  |
| Options              | TurboSteam®, Energy Saver, Low Static, Wrinkle Care, Damp Dry Signal, Drum Light, Cycle List Edit, Signal, Smart Diagnosis, Control Lock, Cycle Optimization, Wi-Fi / Remote Start, Brightness, Factory Reset |
| Temperature Settings | High, Medium/High, Medium, Low/Medium, Low  |
| Drying Levels        | Very, More, Normal, Less, Damp  |
| Manual Dry Times     | 10 min – 100 min (10 min increments)  |

## FABRIC CARE (WASHER)

|                   |                |
|-------------------|----------------|
| AI DD®            | Yes (2.0)      |
| Wash Technology   | TurboWash® 360 |
| Steam Technology  | Yes            |
| Allergiene® Cycle | Yes            |
| Sanitary Cycle    | Yes            |

## FABRIC CARE (DRYER)

|  |             |
|--|-------------|
| Steam Technology                                 | TurboSteam® |
| AI Sensor Dry™                                   | Yes         |
| Sensor Dry                                       | Yes         |
| Precise Temperature Control with Variable Heater | Yes         |

## CONVENIENCE

|  |   |
|--|---|
| Vibration Sensing (Cabinet Vibration Sensor) | Yes   |
| TrueBalance™ Anti-Vibration System           | Yes   |
| Dispenser Type                               | ezDispense Cartridge (Detergent, Softener), Main Wash, Bleach (Cup) |
| End of Cycle Signal                          | Yes   |
| LoadSense                                    | Yes   |
| Control Lock                                 | Yes   |
| Auto Suds Removal                            | Yes   |
| Drum Light                                   | Yes (Washer & Dryer)  |
| FlowSense™ Duct Clogging Indicator           | Yes   |
| Wrinkle Care Option                          | Yes   |
| Remaining Time Display/Status Indicator(s)   | Yes   |
| Reversible Doors                             | No  |
| Venting Option                               | Electric: 3 Way Venting<br>Gas: 2 Way Venting                       |
| 3 Minute Installation Check                  | Yes   |
| 4 Adjustable Leveling Legs                   | Yes   |
| ADA Compliant                                | No  |

## SMART FEATURES

|                                   |                                |
|-----------------------------------|--------------------------------|
| Wi-Fi Enabled                     | Yes                            |
| ThinQ® Technology                 | Yes                            |
| ThinQ Care                        | Yes                            |
| Voice Control                     | Google Assistant, Amazon Alexa |
| SmartDiagnosis™                   | Yes                            |
| Remote Start (On/Off)             | Yes                            |
| Remote Monitoring & Notifications | Yes                            |
| Energy Monitoring                 | Yes                            |
| Smart Learner                     | Yes                            |
| Smart Pairing                     | Yes                            |
| Tub Clean Coach                   | Yes                            |

## MOTOR AND AGITATOR

|            |                             |
|------------|-----------------------------|
| Motor Type | Inverter Direct Drive Motor |
| Axis       | Horizontal                  |

## MATERIALS AND FINISHES

|                        |                                |
|------------------------|--------------------------------|
| Drum Material – Washer | NeveRust™ Stainless Steel Drum |
| Drum Material – Dryer  | NeveRust™ Stainless Steel Drum |
| Door / Rim             | Large Circle / Chrome Rim      |
| Tempered Glass Doors   | Yes                            |

## TECHNICAL SPECS

|                                  |  |
|----------------------------------|--|
| Electrical Requirements – Washer | 120V, 60 Hz, 11 Amps   |
| Electrical Requirements – Dryer  | 120/240V, 60Hz, 26A (Electric)<br>120V, 60Hz, 11.5A (Gas)                |
| Gas Dryer BTU Rating             | 20,000   |
| Power Outlet Location            | Within 60" of Either Side of Unit  |
| Plug Type – Washer               | 3-Prong (Cord Attached to Unit)  |
| Plug Type – Dryer                | Gas: 3-Prong (Cord Attached to Unit)<br>Electric: 4-Wire (Cord Required) |
| Min. / Max. Water Pressure       | 20 - 120 psi   |

## OPTIONAL ACCESSORIES

|                   |  |
|-------------------|--|
| Drying Rack       | 3750EL1001A                                    |
| LP Conversion Kit | 383EEL3002D                                    |
| Side Vent Kit     | 3911EZ9131X (Interchangeable with 383EEL9001B) |

## DIMENSIONS

|                                   |   |
|-----------------------------------|---|
| Product (W x H x D)               | 27" x 74 3/8" x 32 5/8"                                       |
| Depth with Door Open              | 57 3/8"   |
| Cutout Dimensions (W x H x D)     | 29" x 75 3/8" x 36 5/8"                                       |
| Carton Dimensions (W x H x D)     | 29 3/4" x 78 5/8" x 33 3/8"                                   |
| Approx. Weight (Product / Carton) | Elec: 317.5 lbs. / 342.2 lbs.<br>Gas: 319.7 lbs. / 344.4 lbs. |

## LIMITED WARRANTY

|                    |          |
|--------------------|----------|
| Parts and Labor    | 1 Year   |
| Direct Drive Motor | 10 Years |
| Drum               | 3 Years  |

### DIMENSIONS / CLEARANCES

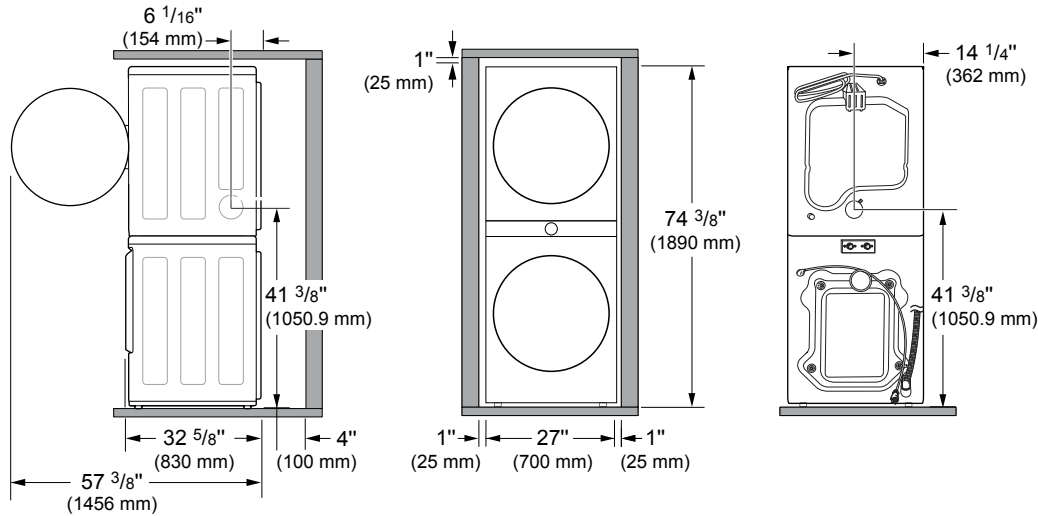

### Dimensions / Clearances

To ensure sufficient clearance for water inlet hoses, drain hose and airflow, allow minimum clearances of at least 1" (2.5 cm) at the sides and 4" (10 cm) behind the appliance. Be sure to allow for wall, door, or floor moldings that may increase the required clearances.

### Exhaust

Choose a location that allows for proper exhaust installation. A gas dryer must be exhausted to the outdoors.

### SPACING FOR RECESSED AREA OR CLOSET INSTALLATION

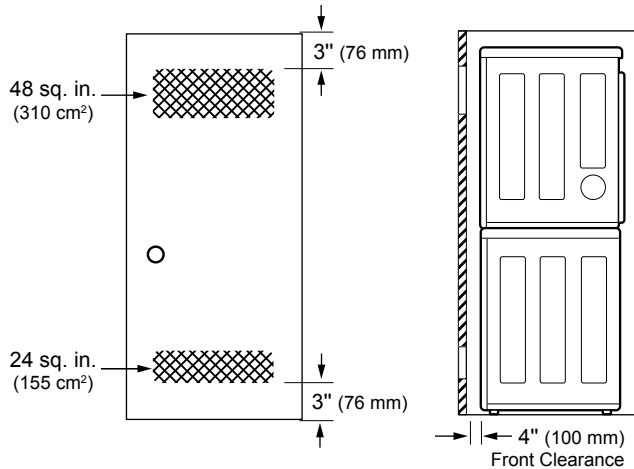

### Closet Ventilation Requirements

Closets with doors must have both an upper and lower vent to prevent heat and moisture buildup in the closet. One upper vent opening with a minimum opening of 48 sq. in. (310 cm<sup>2</sup>) must be installed no lower than 6 feet above the floor. One lower vent opening with a minimum opening of 24 sq. in. (155 cm<sup>2</sup>) must be installed no more than one foot above the floor. Install vent grills in the door or cut down the door at the top and bottom to form openings. Louvered doors with equivalent ventilation openings are also acceptable.

### ELECTRIC & GAS CONNECTION LOCATIONS (REAR VIEW)

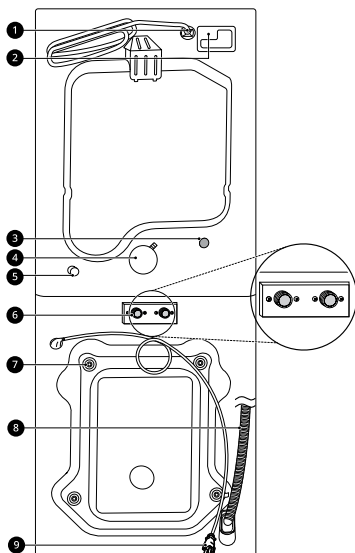

- 1 Power Cord (for Gas Models)
- 2 Terminal Block Access Panel (for Electric Models)
- 3 Cold Water Inlet
- 4 Exhaust Duct Outlet
- 5 Gas connection (for Gas Models)
- 6 Hot and Cold Water Inlets
- 7 Shipping Bolts
- 8 Drain Hose
- 9 Power Cord (for Washer)

## VENTING THE DRYER

- If connecting to existing ductwork, make sure it is suitable and clean before installing the dryer.
- Venting must conform to local building codes.
- Gas dryers **MUST** exhaust to the outdoors.
- Use only 4-inch (10.2 cm) rigid, semi-rigid or flexible metal ductwork inside the dryer cabinet and for venting outside.
- The exhaust duct must be 4 inches (10.2 cm) in diameter with no obstructions. The exhaust duct should be kept as short as possible. Make sure to clean any old ducts before installing your new dryer.
- Rigid, semi-rigid or flexible metal ducting is recommended for use between the dryer and the wall. All non-rigid metal transition duct must be UL-listed. Use of other materials for transition duct could affect drying time.
- Ductwork is not provided with the dryer. You should obtain the necessary ductwork locally. The vent hood should have hinged dampers to prevent backdraft when the dryer is not in use.
- The total length of flexible metal duct must not exceed 8 ft. (2.4 m).

### NOTE:

- Deduct 6 ft. (1.8 m) for each additional elbow. Do not use more than four 90° elbows.

## ROUTING AND CONNECTING DUCTWORK

### NOTE:

Follow the guidelines below to maximize drying performance and reduce lint buildup and condensation in the ductwork. Ductwork and fittings are **NOT** included and must be purchased separately.

- Use 4-inch (10.2 cm) diameter rigid, semi-rigid or flexible metal ductwork.
- The exhaust duct run should be as short as possible.
- Use as few elbow joints as possible.
- The male end of each section of exhaust duct must point away from the dryer.
- Use duct tape on all duct joints.
- Insulate ductwork that runs through unheated areas in order to reduce condensation and lint buildup on duct surfaces.
- Incorrect or inadequate exhaust systems are not covered by the dryer warranty. Dryer failures or service required because of such exhaust systems will not be covered by the dryer warranty.

## CONNECTING THE WATER INLET HOSE

The dryer must be connected to the cold water tap using the new water supply hose. Do not reuse old hoses.

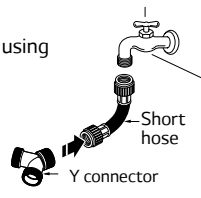

## DUCTWORK

| Wall Cap Type | Number of 90° Elbows | Maximum length of 4-inch diameter rigid metal duct |
|---------------|----------------------|--|
|               | 0                    | 65 ft. (19.8 m)                                    |
|               | 1                    | 55 ft. (16.8 m)                                    |
|               | 2                    | 47 ft. (14.3 m)                                    |
|               | 3                    | 36 ft. (11.0 m)                                    |
|               | 4                    | 28 ft. (8.5 m)                                     |
|               | 0                    | 55 ft. (16.8 m)                                    |
|               | 1                    | 47 ft. (14.3 m)                                    |
|               | 2                    | 41 ft. (12.5 m)                                    |
|               | 3                    | 30 ft. (9.1 m)                                     |
|               | 4                    | 22 ft. (6.7 m)                                     |

## CORRECT VENTING

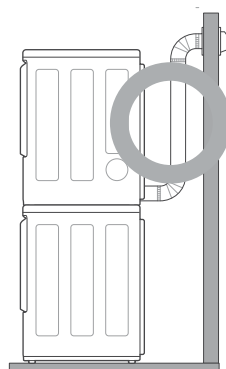

## INCORRECT VENTING

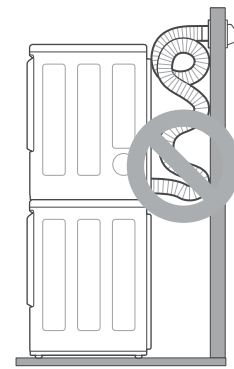

## CONNECTING GAS DRYERS

### Gas Supply Requirements

- As shipped from the factory, this dryer is configured for use with natural gas (NG). It can be converted for use with propane (LP) gas. Gas pressure must not exceed 8-inch (20.4 cm) water column for NG, or 13-inch (33.1 cm) water column for LP.
- A qualified service or gas company technician must connect the dryer to the gas service.

### Electrical Requirements for Gas Models Only

- This dryer must be plugged into a 120-VAC, 60-Hz. grounded outlet protected by a 15-ampere fuse or circuit breaker.
- This dryer is equipped with a three-prong grounding plug for protection against shock hazard and should be plugged directly into a properly grounded three-prong receptacle. Do not cut or remove the grounding prong from this plug.

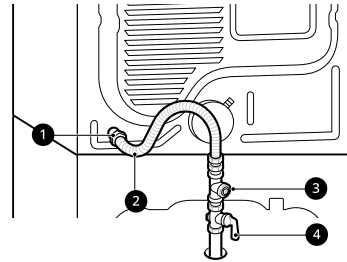

- ① 3/8" NPT Gas Connection
- ② AGA/CSA-Certified Stainless Steel Flexible Connector
- ③ 1/8" NPT Pipe Plug
- ④ Gas Supply Shutoff Valve

## CONNECTING ELECTRIC DRYERS

### Electrical Requirements for Electric Models Only

- This dryer must be connected to a grounded metal, permanent wiring system, or an equipment-grounding conductor must be run with the circuit conductors and connected to the equipment-grounding terminal or lead on the dryer.
- The dryer has its own terminal block that must be connected to a separate 240 VAC, 60-Hertz, single-phase circuit, fused at 30 amperes (the circuit must be fused on both sides of the line). **ELECTRICAL VOLTAGE LISTED ON THE NAMEPLATE. DO NOT CONNECT THE DRYER TO 110-, 115-, OR 120-VOLT CIRCUIT.**
- If the branch circuit to dryer is 15 ft. (4.5 m) or less in length, use UL (Underwriters Laboratories) listed No.-10 AWG wire (copper wire only), or as required by local codes. If over 15 ft. (4.5 m), use UL-listed No.-8 AWG wire (copper wire only), or as required by local codes. Allow sufficient slack in wiring so the dryer can be moved from its normal location when necessary.
- The power cord (pigtail) connection between the wall receptacle and the dryer terminal block IS NOT supplied with the dryer. Type of pigtail and gauge of wire must conform to local codes.

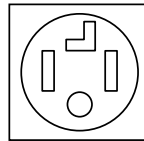

### FOUR-WIRE POWER CORD

- A 4-wire connection is required for all mobile and manufactured home installations, as well as all new construction after January 1, 1996.
- A UL-listed strain relief is required.
- Use a 30-amp, 240-volt, 4-wire, UL-listed power cord with #10 AWG-minimum copper conductor and closed loop or forked terminals with upturned ends.

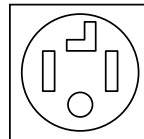

### FOUR-WIRE DIRECT WIRE

- A 4-wire connection is required for all mobile and manufactured home installations, as well as all new construction after January 1, 1996.
- A UL-listed strain relief is required.
- Use UL-listed 4-wire #10 AWG minimum copper conductor cable. Allow at least 5 ft. (1.5 m) of wire to allow for removal and reinstallation of the dryer.