

WashTower™ with Center Control™

- Single Unit WashTower™ Design with Center Control
- 5.0 cu. ft. Washer / 7.4 cu. ft. Dryer
- TurboWash® 360° Wash Technology
- TurboSteam® Dryer
- SteamFresh™ Dryer Cycle
- Built-In Intelligence with AIDD / AI Fabric Sensor, Smart Learner, Smart Pairing™
- 6 Wash Cycles / 10 Wash Options
- 6 Dry Cycles / 9 Dry Options
- Allergiene™ Cycle
- Direct Drive Motor (10-Year Limited Warranty)
- NeveRust™ Stainless Steel Drum (Washer & Dryer)
- Drying Rack Included
- LG ThinQ® Technology (Wi-Fi)



COLOR AVAILABILITY

- WSEX200HNA (Electric) – Noble Steel
- WSGX201HNA (Gas) – Noble Steel

CAPACITY

Washer Capacity (cu. ft.)	5.0
Dryer Capacity (cu. ft.)	7.4

APPEARANCE

Center Control™	Yes
Electronic Controls with LED Display	Yes
Touch Buttons	Yes

ENERGY & WATER

ENERGY STAR® Qualified	Yes
CEE Qualified	Tier 3
Integrated Modified Energy Factor (IMEF)	3.1
Integrated Water Factor (IWF)	2.9
CEF	Electric: 3.94 Gas: 3.49

WASH CYCLES

Number of Cycles	6
Wash Cycles	Normal, Bedding, Delicates, Heavy Duty, Speed Wash, Downloaded

WASH OPTIONS

Number of Options	10
Options	TurboWash®, Steam, Extra Rinse, Pre-wash, Sanitary, Tub Clean, Drum Light, Control Lock, Signal, Wi-Fi / Remote Start

WASH DETAILS

Internal Heater	Yes
Number of Wash / Rinse Temps	5
Wash / Rinse Temps	Hot, Warm / Hot, Warm, Cold / Warm, Cold
Number of Spin Speeds	5
Spin Speeds	High, Medium / High, Medium, Low, No Spin
Max RPM	1,300
Water Levels	Load Sensing
Number of Soil Levels	5
AAFA Certified	Yes

DRYER CYCLES

Number of Cycles	6
Sensor Dry Cycles	Normal, Bedding, Delicates, Heavy Duty, Small Load, Downloaded

DRYER OPTIONS

Number of Options	9
Options	Wrinkle Care, TurboSteam™, Reduce Static, Energy Saver, Steam Fresh, Drum Light, Control Lock, Signal, Wi-Fi / Remote Start
Temperature Settings	High, Medium / High, Medium, Low / Medium, Low
Drying Levels	Very, More, Normal, Less, Damp
Manual Dry Times	60 min., 50 min., 40 min., 30 min., 20 min.

FABRIC CARE (WASHER)

AI DD™	Yes
Wash Technology	TurboWash® 360
Steam Technology	Yes
Allergiene™ Cycle	Yes
Sanitary Cycle	Yes

FABRIC CARE (DRYER)

Steam Technology	TurboSteam®
AI Sensor Dry	Yes
Sensor Dry	Yes
Precise Temperature Control with Variable Heater	Yes

CONVENIENCE

TrueBalance™ Anti-Vibration System	Yes
Dispenser Type	4 Tray (Prewash, Main Wash (with liquid detergent cup), Bleach, Fabric Softener)
Easy Loading TilTub™	Yes
LoDecibel™ Quiet Operation	Yes
End of Cycle Signal	Yes
LoadSense	Yes
Child Lock	Yes
Auto Suds Removal	Yes
Drum Light	Yes (Washer & Dryer with Option Button)
FlowSense™ Duct Clogging Indicator	Yes
Wrinkle Care Option	Yes
End of Cycle Signal	Yes
Remaining Time Display / Status Indicator(s)	Yes
Reversible Doors	No
Venting Option	Electric: 3 Way Venting Gas: 2 Way Venting
3 Minute Installation Check	Yes
4 Adjustable Leveling Legs	Yes
ADA Compliant	No

SMART FEATURES

Wi-Fi Enabled	Yes
ThinQ®	Yes
Proactive Customer Care	Yes
Voice Control	Google Assistant, Amazon Alexa
SmartDiagnosis™	Yes
Remote Start (On / Off)	Yes
Remote Monitoring & Notifications	Yes
Energy Monitoring	Yes
Smart Learner	Yes
Smart Pairing	Yes
Tub Clean Coach	Yes

MOTOR AND AGITATOR

Motor Type	Inverter Direct Drive Motor
Axis	Horizontal

MATERIALS AND FINISHES

Drum Material – Washer	NeveRust™ Stainless Steel Drum
Drum Material – Dryer	NeveRust™ Stainless Steel Drum
Door / Rim	Large Circle / Chrome Rim

TECHNICAL SPECS

Electrical Requirements – Washer	120V, 10 Amps
Electrical Requirements – Dryer	120V, 15 Amps (Gas) 240V, 30 Amps (Electric)
Gas Dryer BTU Rating	20,000 Feet
Power Outlet Location	Within 60" of Either Side of Unit
Plug Type – Washer	3-Prong (Cord Attached to Unit)
Plug Type – Dryer	Gas: 3-Prong (Cord Attached to Unit) Electric: 4-Wire (Cord Required)
Min. / Max. Water Pressure	20–120 psi
NSF®-Certified*	Yes

INCLUDED ACCESSORIES

	Drying Rack
--	-------------

OPTIONAL ACCESSORIES

LP Conversion Kit	383EEL3002D
Side Vent Kit	3911EZ9131X (Replaces 383EEL9001B)

DIMENSIONS

Product (W x H x D)	27" x 74 3/8" x 32 3/4"
Depth with Door Open	58"
Carton Dimensions (W x H x D)	30 1/16" x 79 11/32" x 33 23/32"
Approx. Weight (Product / Carton)	Electric: 320 lbs. / 355 lbs. Gas: 320 lbs. / 355 lbs.

LIMITED WARRANTY

Parts and Labor	2 Years
Direct Drive Motor	10 Years
Drum	3 Years

DIMENSIONS / CLEARANCES

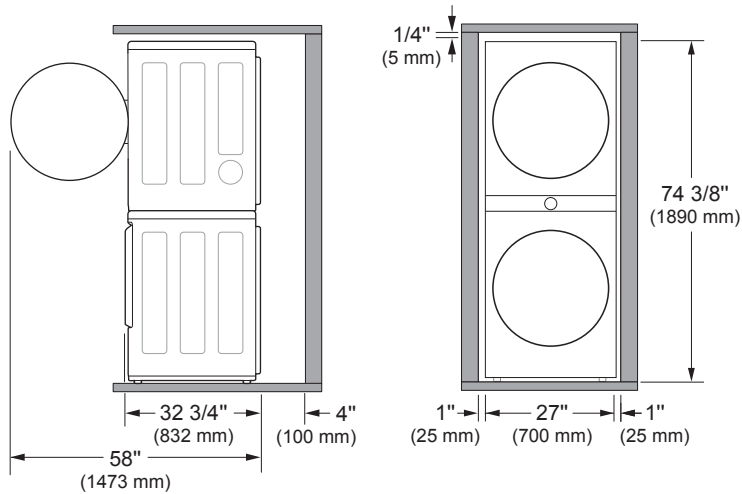

Dimensions / Clearances

To ensure sufficient clearance for water inlet hoses, drain hose and airflow, allow minimum clearances of at least 1" (2.5 cm) at the sides and 4" (10 cm) behind the appliance. Be sure to allow for wall, door, or floor moldings that may increase the required clearances.

Exhaust

A location that allows for proper exhaust installation. A gas dryer must be exhausted to the outdoors.

SPACING FOR RECESSED AREA OR CLOSET INSTALLATION

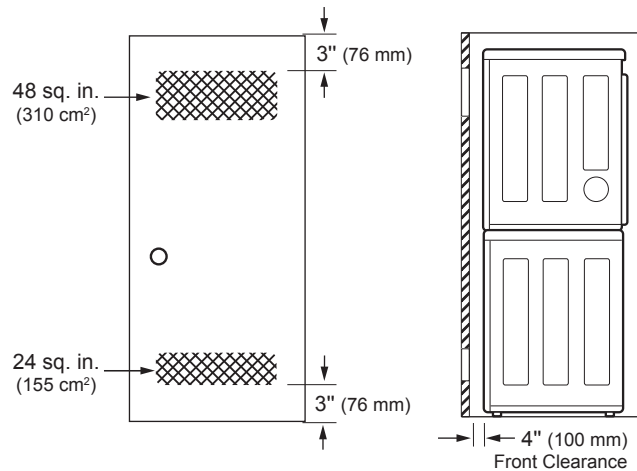

Closet Ventilation Requirements

Closets with doors must have both an upper and lower vent to prevent heat and moisture buildup in the closet. One upper vent opening with a minimum opening of 48 sq. in. (310 cm²) must be installed no lower than 6 feet above the floor. One lower vent opening with a minimum opening of 24 sq. in. (155 cm²) must be installed no more than one foot above the floor. Install vent grills in the door or cut down the door at the top and bottom to form openings. Louvered doors with equivalent ventilation openings are also acceptable.

ELECTRIC & GAS CONNECTION LOCATIONS (REAR VIEW)

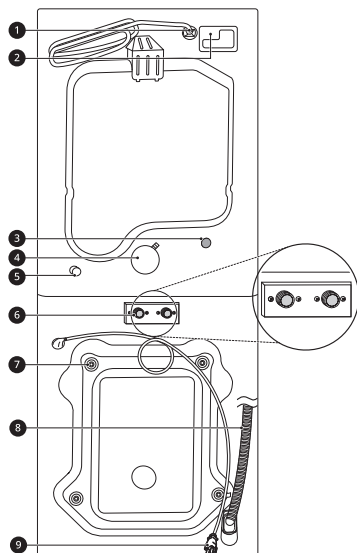

- ① Power Cord (for Gas Models)
- ② Terminal Block Access Panel (for Electric Models)
- ③ Cold Water Inlet
- ④ Exhaust Duct Outlet
- ⑤ Gas connection (for Gas Models)
- ⑥ Hot and Cold Water Inlets
- ⑦ Shipping Bolts
- ⑧ Drain Hose
- ⑨ Power Cord (for Washer)

VENTING THE DRYER

- If connecting to existing ductwork, make sure it is suitable and clean before installing the dryer.
- Venting must conform to local building codes.
- Gas dryers **MUST** exhaust to the outdoors.
- Use only 4-inch (10.2 cm) rigid, semi-rigid or flexible metal ductwork inside the dryer cabinet and for venting outside.
- The exhaust duct must be 4 inches (10.2 cm) in diameter with no obstructions. The exhaust duct should be kept as short as possible. Make sure to clean any old ducts before installing your new dryer.
- Rigid, semi-rigid or flexible metal ducting is recommended for use between the dryer and the wall. All non-rigid metal transition duct must be UL-listed. Use of other materials for transition duct could affect drying time.
- Ductwork is not provided with the dryer. You should obtain the necessary ductwork locally. The vent hood should have hinged dampers to prevent backdraft when the dryer is not in use.
- The total length of flexible metal duct must not exceed 8 ft. (2.4 m).

NOTE:

- Deduct 6 ft. (1.8 m) for each additional elbow. Do not use more than four 90° elbows.

ROUTING AND CONNECTING DUCTWORK

NOTE:

Follow the guidelines below to maximize drying performance and reduce lint buildup and condensation in the ductwork. Ductwork and fittings are **NOT** included and must be purchased separately.

- Use 4-inch (10.2 cm) diameter rigid, semi-rigid or flexible metal ductwork.
- The exhaust duct run should be as short as possible.
- Use as few elbow joints as possible.
- The male end of each section of exhaust duct must point away from the dryer.
- Use duct tape on all duct joints.
- Insulate ductwork that runs through unheated areas in order to reduce condensation and lint buildup on duct surfaces.
- Incorrect or inadequate exhaust systems are not covered by the dryer warranty. Dryer failures or service required because of such exhaust systems will not be covered by the dryer warranty.

CONNECTING THE WATER INLET HOSE

The dryer must be connected to the cold water tap using the new water supply hose. Do not reuse old hoses.

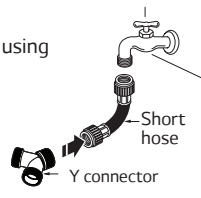

DUCTWORK

Wall Cap Type	Number of 90° Elbows	Maximum length of 4-inch diameter rigid metal duct
	0	65 ft. (19.8 m)
	1	55 ft. (16.8 m)
	2	47 ft. (14.3 m)
	3	36 ft. (11.0 m)
	4	28 ft. (8.5 m)
	0	55 ft. (16.8 m)
	1	47 ft. (14.3 m)
	2	41 ft. (12.5 m)
	3	30 ft. (9.1 m)
	4	22 ft. (6.7 m)

CORRECT VENTING

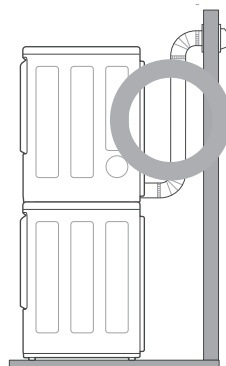

INCORRECT VENTING

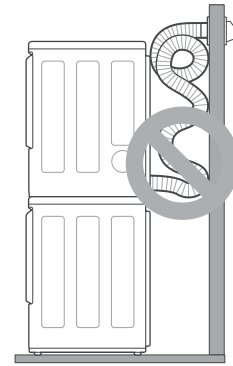

CONNECTING GAS DRYERS

Gas Supply Requirements

- As shipped from the factory, this dryer is configured for use with natural gas (NG). It can be converted for use with propane (LP) gas. Gas pressure must not exceed 8-inch (20.4 cm) water column for NG, or 13-inch (33.1 cm) water column for LP.
- A qualified service or gas company technician must connect the dryer to the gas service.

Electrical Requirements for Gas Models Only

- This dryer must be plugged into a 120-VAC, 60-Hz. grounded outlet protected by a 15-ampere fuse or circuit breaker.
- This dryer is equipped with a three-prong grounding plug for protection against shock hazard and should be plugged directly into a properly grounded three-prong receptacle. Do not cut or remove the grounding prong from this plug.

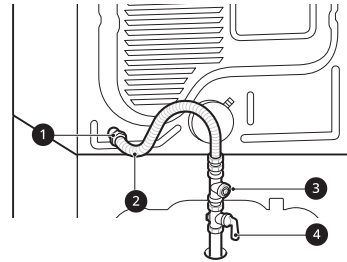

- 1 3/8" NPT Gas Connection
- 2 AGA/CSA-Certified Stainless Steel Flexible Connector
- 3 1/8" NPT Pipe Plug
- 4 Gas Supply Shutoff Valve

CONNECTING ELECTRIC DRYERS

Electrical Requirements for Electric Models Only

- This dryer must be connected to a grounded metal, permanent wiring system, or an equipment-grounding conductor must be run with the circuit conductors and connected to the equipment-grounding terminal or lead on the dryer.
- The dryer has its own terminal block that must be connected to a separate 240 VAC, 60-Hertz, single-phase circuit, fused at 30 amperes (the circuit must be fused on both sides of the line). **ELECTRICAL VOLTAGE LISTED ON THE NAMEPLATE. DO NOT CONNECT THE DRYER TO 110-, 115-, OR 120-VOLT CIRCUIT.**
- If the branch circuit to dryer is 15 ft. (4.5 m) or less in length, use UL (Underwriters Laboratories) listed No.-10 AWG wire (copper wire only), or as required by local codes. If over 15 ft. (4.5 m), use UL-listed No.-8 AWG wire (copper wire only), or as required by local codes. Allow sufficient slack in wiring so the dryer can be moved from its normal location when necessary.
- The power cord (pigtail) connection between the wall receptacle and the dryer terminal block IS NOT supplied with the dryer. Type of pigtail and gauge of wire must conform to local codes

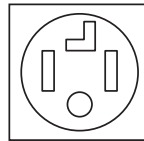

FOUR-WIRE POWER CORD

- A 4-wire connection is required for all mobile and manufactured home installations, as well as all new construction after January 1, 1996.
- A UL-listed strain relief is required.
- Use a 30-amp, 240-volt, 4-wire, UL-listed power cord with #10 AWG-minimum copper conductor and closed loop or forked terminals with upturned ends.

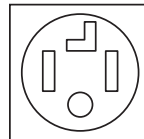

FOUR-WIRE DIRECT WIRE

- A 4-wire connection is required for all mobile and manufactured home installations, as well as all new construction after January 1, 1996.
- A UL-listed strain relief is required.
- Use UL-listed 4-wire #10 AWG minimum copper conductor cable. Allow at least 5 ft. (1.5 m) of wire to allow for removal and reinstallation of the dryer.