



# OWNER'S MANUAL

**Stainless Steel Professional  
Range Hood**

# TABLE OF CONTENTS

MODEL INFORMATION .....	2
CONSUMER SUPPORT .....	3
SAFETY INFORMATION .....	4
CONTROLS AND FEATURES .....	6
CARE AND CLEANING .....	7
For Your Safety .....	7
Metal Grease Filter .....	7
Charcoal Filter .....	7
Glass Canopy .....	8
Stainless Steel Hood Surfaces .....	8
Light Bulbs .....	8
TROUBLESHOOTING .....	9
MONOGRAM LIMITED WARRANTY .....	11

## MODEL INFORMATION

### MODEL NUMBERS

ZV36

ZV48

---

### WRITE DOWN THE MODEL AND SERIAL NUMBERS

You'll find them on a label on the hood.

Use these numbers in any correspondence or service calls concerning your appliance.

**Please write these numbers here:**

\_\_\_\_\_

Model Number

\_\_\_\_\_

Serial Number

# CONSUMER SUPPORT

## MONOGRAM WEBSITE

Have a question or need assistance with your appliance? Try the Monogram website 24 hours a day, any day of the year! You can also shop for more great Monogram products and take advantage of all our on-line support services designed for your convenience. In the US: [monogram.com](http://monogram.com) or in Canada: [monogram.ca](http://monogram.ca)

---

## REGISTER YOUR APPLIANCE

Register your new appliance on-line at your convenience! Timely product registration will allow for enhanced communication and prompt service under the terms of your warranty, should the need arise. You may also mail in the pre-printed registration card included in the packing material. In the US: [monogram.com/register](http://monogram.com/register) or in Canada: [Prodsupport.mabe.ca/crm/Products/ProductRegistration.aspx](http://Prodsupport.mabe.ca/crm/Products/ProductRegistration.aspx)

---

## SCHEDULE SERVICE

Expert Monogram repair service is only one step away from your door. To request service in the US, visit our website at [monogram.com/contact](http://monogram.com/contact). or in Canada, visit our website at [monogram.ca/contact](http://monogram.ca/contact)

---

## REMOTE CONNECTIVITY

For assistance with wireless network connectivity (for models with remote enable), visit our website at [monogram.com/connect](http://monogram.com/connect)

---

## PARTS AND ACCESSORIES

Individuals qualified to service their own appliances can have parts or accessories sent directly to their homes (VISA, MasterCard and Discover cards are accepted). Order on-line today 24 hours every day.

In the US: [monogram.com/use-and-care/parts](http://monogram.com/use-and-care/parts)

**Instructions contained in this manual cover procedures to be performed by any user. Other servicing generally should be referred to qualified service personnel. Caution must be exercised, since improper servicing may cause unsafe operation.**

Customers in Canada should consult the nearest Mabe service center, visit our website at [monogram.ca](http://monogram.ca)

---

## CONTACT US

If you are not satisfied with the service you receive from Monogram, contact us on our website with all the details including your phone number, or write to:

In the US: General Manager, Customer Relations | Monogram Appliances, Appliance Park | Louisville, KY 40225  
[monogram.com/contact](http://monogram.com/contact)

In Canada: [monogram.ca/contact](http://monogram.ca/contact)

# IMPORTANT SAFETY INFORMATION

## READ ALL INSTRUCTIONS BEFORE USING THE APPLIANCE

### ▲WARNING

Read all safety instructions before using the product. Failure to follow these instructions may result in fire, electrical shock, serious injury or death.

### ▲WARNING

#### GENERAL SAFETY INSTRUCTIONS

### ▲WARNING

TO REDUCE THE RISK OF FIRE, ELECTRIC SHOCK OR INJURY TO PERSONS, OBSERVE THE FOLLOWING:

- A. Use this unit only in the manner intended by the manufacturer. If you have questions, contact the manufacturer.
- B. Before servicing or cleaning unit, switch power off at service panel and lock the service disconnecting means to prevent power from being switched on accidentally. When the service disconnecting means cannot be locked, securely fasten a prominent warning device, such as a tag, to the service panel.
- C. Do not use this unit with any solid-state speed control device.
- D. This unit must be grounded.

### ▲CAUTION

FOR GENERAL VENTILATING USE ONLY. DO NOT USE TO EXHAUST HAZARDOUS OR EXPLOSIVE MATERIALS AND VAPORS.

### ▲WARNING

TO REDUCE THE RISK OF INJURY TO PERSONS IN THE EVENT OF A RANGE TOP GREASE FIRE, OBSERVE THE FOLLOWING\*:

- A. SMOTHER FLAMES with a close-fitting lid, cookie sheet or metal tray, then turn off the burner. BE CAREFUL TO PREVENT BURNS. If the flames do not go out immediately, EVACUATE AND CALL THE FIRE DEPARTMENT.
- B. NEVER PICK UP A FLAMING PAN—You may be burned.
- C. DO NOT USE WATER, including wet dishcloths or towels—a violent steam explosion will result.
- B Use an extinguisher ONLY if:
  - 1. You know you have a Class ABC extinguisher, and you already know how to operate it.
  - 2. The fire is small and contained in the area where it started.
  - 3. The fire department is being called.
  - 4. You can fight the fire with your back to an exit.

\*Based on "[Kitchen Firesafety Tips](#)" published by NFPA.

### ▲WARNING

TO REDUCE THE RISK OF A RANGE TOP GREASE FIRE:

- A. Never leave surface units unattended at high settings. Boilovers cause smoking and greasy spillovers that may ignite. Heat oils slowly on low or medium settings.
- B. Always turn hood ON when cooking at high heat or when flambéing food (i.e. Crepes Suzette, Cherries Jubilee, Peppercorn Beef Flambé).
- C. Clean ventilating fans frequently. Grease should not be allowed to accumulate on fan or filter.
- D. Use proper pan size. Always use cookware appropriate for the size of the surface element.

### ▲WARNING

TO REDUCE THE RISK OF FIRE, ELECTRIC SHOCK OR INJURY TO PERSONS, OBSERVE THE FOLLOWING:

- A. Installation work and electrical wiring must be done by qualified person(s) in accordance with all applicable codes and standards, including fire-related construction.
- B. Sufficient air is needed for proper combustion and exhausting of gases through the flue (chimney) of fuel burning equipment to prevent back drafting. Follow the heating equipment manufacturer's guidelines and safety standards such as those published by the National Fire Protection Association (NFPA), and the American Society for Heating, Refrigeration and Air Conditioning Engineers (ASHRAE), and the local code authorities. When applicable, install any makeup (replacement) air system in accordance with local building code requirements. Visit [Monogram.com](http://Monogram.com) for available makeup air solutions.
- C. When cutting or drilling into wall or ceiling, do not damage electrical wiring and other hidden utilities.
- D. Ducted fans must always be vented to the outdoors.

### ▲WARNING

TO REDUCE THE RISK OF FIRE, USE ONLY METAL DUCTWORK.

- Do not attempt to repair or replace any part of your hood unless it is specifically recommended in this manual. All other servicing should be referred to a qualified technician.

## READ AND SAVE THESE INSTRUCTIONS

# CONSIGNES DE SÉCURITÉ IMPORTANTES

## VEUILLEZ LIRE TOUTES LES CONSIGNES AVANT D'UTILISER L'APPAREIL

### ▲ AVERTISSEMENT

Veillez lire toutes les consignes avant d'utiliser ce produit. Le non-respect de ces instructions pourrait entraîner un incendie, un choc électrique, une blessure grave voire la mort.

### ▲ AVERTISSEMENT

#### CONSIGNES GÉNÉRALES DE SÉCURITÉ

### ▲ AVERTISSEMENT

**POUR RÉDUIRE LE RISQUE D'INCENDIE, DE SECOURS ÉLECTRIQUE OU DE BLESSURE CORPORELLE, OBSERVEZ LES PRÉCAUTIONS SUIVANTES :**

- A. N'utilisez cet appareil que de la manière prévue par le fabricant. Si vous avez des questions, appelez le fabricant.
- B. Avant de réparer ou de nettoyer votre appareil, débranchez le courant au niveau du panneau de service et verrouillez les mécanismes de débranchement de service pour éviter tout branchement accidentel au courant. Si vous ne pouvez pas verrouiller les mécanismes de débranchement de service, attachez soigneusement un avertissement bien visible, comme une étiquette, au panneau de service.
- C. N'utilisez jamais cet appareil avec un mécanisme de réglage de la vitesse à semi-conducteurs.
- D. Cet appareil doit être bien mis à la terre.

### ▲ ATTENTION

**UNIQUEMENT À USAGE DE VENTILATION GÉNÉRALE. N'UTILISEZ JAMAIS POUR L'ÉCHAPPEMENT DE MATIÈRES ET DE VAPEURS EXPLOSIVES.**

### ▲ AVERTISSEMENT

**POUR RÉDUIRE LE RISQUE DE BLESSURE CORPORELLE SI DE LA GRAISSE PREND FEU SUR LA SURFACE DE CUISSON DU FOUR, SUIVEZ LES INSTRUCTIONS SUIVANTES\* :**

- A. **ÉTOUFFEZ LES FLAMMES** avec un couvercle qui convient, une tôle à biscuits ou un plateau en métal, puis éteignez le brûleur. FAITES BIEN ATTENTION DE NE PAS VOUS BRÛLER. Si les flammes ne s'éteignent pas immédiatement, SORTEZ ET APPELEZ LES POMPIERS.
- B. **NE DÉPLACEZ JAMAIS UNE CASSEROLE QUI FLAMBE** – Vous pouvez vous brûler.
- C. **N'UTILISEZ JAMAIS D'EAU**, en particulier de serviette ou de chiffon mouillé – il se produira une explosion violente de vapeur brûlante.
- D. **N'UTILISEZ UN EXTINCTEUR** que si :
  - 1. Vous avez un extincteur de classe ABC et vous savez comment l'utiliser;
  - 2. Le feu est réduit et confiné à l'endroit où il a commencé;
  - 3. Vous avez déjà appelé les pompiers;
  - 4. Vous combattez les flammes en tournant le dos à une sortie.

\* Basé sur l'ouvrage intitulé «Kitchen Fire Safety Tips» publié par la NFPA.

### ▲ AVERTISSEMENT

**RÉDUISEZ LE RISQUE D'UN FEU DE GRAISSE SUR LA SURFACE DE CUISSON DU FOUR :**

- A. Ne laissez jamais sans surveillance les unités de cuisson de surface à une température élevée. Le bouillonnement occasionne des débordements fumants et grasseux qui peuvent prendre feu. Chauffez à feu doux les substances huileuses, avec un réglage bas ou moyen.
- B. Mettez toujours la hotte en marche quand vous cuisinez à haute température ou quand vous faites flamber des aliments (p. ex. crêpes Suzette, cerises Jubilee, Boeuf flambé Peppercorn).
- C. Nettoyez les mécanismes de ventilation fréquemment. Il ne faut pas permettre une accumulation de graisse sur le ventilateur ou sur le filtre.
- D. Utilisez une casserole de bonne taille. Utilisez toujours un ustensile de cuisine qui convienne au diamètre de l'élément de cuisson.

### ▲ AVERTISSEMENT

**POUR RÉDUIRE LE RISQUE D'INCENDIE, DE SECOURS ÉLECTRIQUE OU DE BLESSURE CORPORELLE, OBSERVEZ LES PRÉCAUTIONS SUIVANTES :**

- A. Vous devez faire exécuter tous les travaux d'installation et de câblage électrique par une personne qualifiée, conformément à tous les codes et les normes en vigueur, en particulier ceux de construction relatifs aux incendies.
- B. Vous devez assez d'air pour avoir une bonne combustion et permettre l'évacuation des gaz par le conduit de cheminée du matériel de combustion du carburant, afin d'éviter tout retour d'air. Suivez les directives du fabricant de matériel de combustion et les normes de sécurité comme celles publiées par la National Fire Protection Association (NFPA) et l'American Society for Heating, Refrigeration and Air Conditioning Engineers (ASHRAE), ainsi que les modalités des codes locaux. Le cas échéant, installez un système de compensation d'air (remplacement) conformément aux conditions des codes locaux du bâtiment. Visitez le site [Monogram.com](http://Monogram.com) pour connaître les solutions offertes en matière de système de compensation d'air.
- C. Si vous faites un trou ou une ouverture dans un mur ou un plafond, n'endommagez pas les fils électriques et les autres installations cachées de service public.
- D. Vous devez toujours alimenter les ventilateurs dans les conduits en air en provenance de l'extérieur.

### ▲ AVERTISSEMENT

**POUR RÉDUIRE LE RISQUE D'INCENDIE, N'UTILISEZ QUE DES CONDUITS EN MÉTAL.**

- N'essayez jamais de remplacer ou de réparer un élément de votre hotte si le présent manuel ne le recommande pas expressément. Tout autre entretien doit être effectué par un technicien qualifié.

## LISEZ CES INSTRUCTIONS ET RANGEZ-LES SOIGNEUSEMENT

# INFORMACIÓN IMPORTANTE DE SEGURIDAD

## LEA TODAS LAS INSTRUCCIONES ANTES DE USAR ESTE ELECTRODOMÉSTICO

### ⚠️ ADVERTENCIA

Lea todas las instrucciones de seguridad antes de utilizar este producto. No seguir estas instrucciones puede generar un incendio, una descarga eléctrica, lesiones corporales o la muerte.

### ⚠️ ADVERTENCIA INSTRUCCIONES GENERALES DE SEGURIDAD

#### ⚠️ ADVERTENCIA A FIN DE REDUCIR EL RIESGO

#### DE INCENDIOS, DESCARGAS ELÉCTRICAS O LESIONES PERSONALES, CUMPLA CON LO SIGUIENTE:

- A. Use esta unidad sólo del modo indicado por el fabricante. Ante cualquier duda, comuníquese con el fabricante.
- B. Antes de realizar el servicio técnico o de limpiar la unidad, apague el interruptor del panel del servicio y bloquee el suministro del servicio a fin de evitar que la corriente se active en forma accidental. Cuando el suministro del servicio no pueda ser bloqueado, ajuste de forma segura un dispositivo de advertencia visible, tal como una etiqueta, al panel del servicio.
- C. No use esta unidad con ningún dispositivo de control de velocidad en estado sólido.

#### ⚠️ PRECAUCIÓN SÓLO PARA USO DE VENTILACIÓN GENERAL. NO LO UTILICE PARA HACER SALIR MATERIALES Y VAPORES RIESGOSOS O EXPLOSIVOS.

#### ⚠️ ADVERTENCIA A FIN DE REDUCIR EL RIESGO DE LESIONES SOBRE PERSONAS EN CASO DE INCENDIO DE GRASA SOBRE LA SUPERFICIE DE LA COCINA, CUMPLA CON LO SIGUIENTE\*:

- A. APAGUE LAS LLAMAS con una tapa adherente, bandeja de galletas o bandeja metálica, y luego apague el quemador. TENGA CUIDADO A FIN DE EVITAR QUEMADURAS. Si las llamas no se apagan de inmediato, EVACÚE EL LUGAR Y LLAME AL DEPARTAMENTO DE BOMBEROS.
- B. NUNCA TOME UNA OLLA QUE SE ESTÉ INCENDIANDO — Puede sufrir quemaduras.
- C. NO USE AGUA, , in incluyendo paños o toallas húmedas -

se producirá una explosión violenta de vapor.

D. Use un extinguidor SÓLO si:

1. Sabe que cuenta con un extinguidor Clase ABC, y sabe cómo usarlo.
2. El incendio es pequeño y está contenido en el área donde comenzó.
3. Se llamó al departamento de bomberos.
4. Puede luchar contra el fuego con su espalda hacia una salida.

\*Basado en “Seguridad contra Incendios en una Cocina”, publicado por NFPA.

#### ⚠️ ADVERTENCIA A FIN DE REDUCIR EL RIESGO DE INCENDIO DE GRASA SOBRE LA SUPERFICIE DE UNA COCINA:

- No intente reparar o reemplazar ninguna parte de la campana, a menos que se lo recomiende específicamente en este manual. Cualquier otra reparación deberá ser realizada por un técnico calificado.

## LEA Y GUARDE ESTAS INSTRUCCIONES

# CONTROLS AND FEATURES

## CONTROLS

### 1. Warming lamps ON/OFF switch

The warming lamps are controlled by their own rocker switch. Press the rocker switch for the warming lamps to begin heating.

### 2. Light control

Turn the light control from OFF to HI for the brightest light while cooking.

### 3. Fan control

Turn the fan control speed from OFF to HI as needed.

Continuous use of the fan system while cooking helps keep the kitchen comfortable and less humid. It also reduces cooking odors and soiling moisture that create a frequent need for cleaning.

**NOTE:** When the fan is operating on the lowest setting, it will be very quiet. Always make sure that the fan is turned OFF when you are finished in the kitchen.

### 4. Fan ON indicator light

Comes on when the fan is turned on.

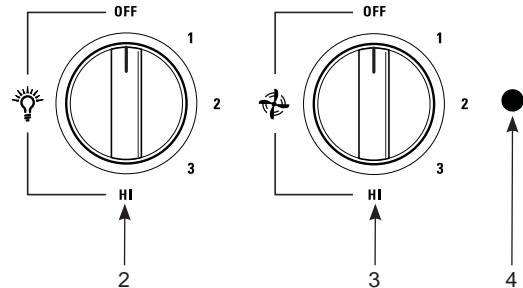
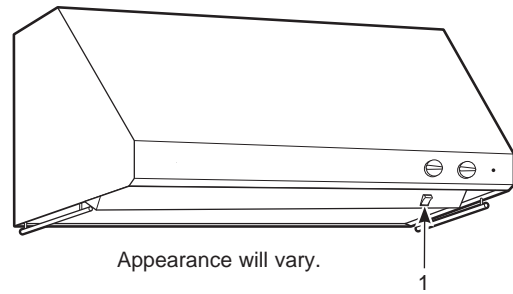

## IMPLEMENT HOLDERS

Implement holder rods are located on each side of the hood.

Use these rods to hang and display cooking utensils such as whisks, spoons, forks or any non-flammable decorative items. Frequently used small pots and pans can also hang from these rods.

**⚠ WARNING** DO NOT hang flammable items from these implement rods.

DO NOT hang items weighing more than 10 pounds on either side, or 20 pounds total weight.

**⚠ AVERTISSEMENT** N'accrochez pas d'articles inflammables à ces tringles.

N'accrochez pas d'articles pesant plus de 5 kg (10 lbs) de chaque côté, soit au total pesant plus de 10 kg (20 lbs).

## ⚠ ADVERTENCIA

**NO cuelgue artículos inflamables de estos barrales.**

**NO cuelgue artículos que pesen más de 10 libras sobre cada lado, o 20 libras de peso total.**

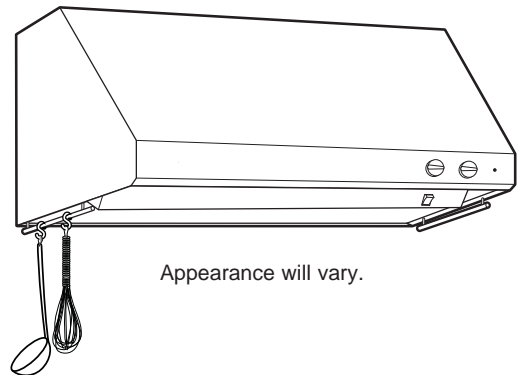

## WARMING SHELF (on some models)

The warming shelf will keep hot, cooked foods at serving temperature. Always start with hot food. Do not use to heat cold food other than crisping crackers, chips or dry cereal.

**⚠ CAUTION** Do not keep food on the warming shelf for more than two hours.

**⚠ CAUTION** Plastic containers or plastic wrap will melt if in direct contact with the warming shelf. Melted plastic may not be removable and is not covered under your warranty.

**⚠ ATTENTION** Ne gardez pas la nourriture sur la tablette chauffante durant plus de deux heures.

## ⚠ ATTENTION

Les contenants ou pellicules en plastique vont fondre s'il sont en contact direct avec la tablette chauffante. Le plastique fondu peut s'avérer impossible à retirer et cet inconvénient n'est pas couvert par la garantie.

## ⚠ PRECAUCIÓN

No guarde comida en el estante para calentar por más de 2 horas.

## ⚠ PRECAUCIÓN

Los envases o envoltorios de plástico se derretirán si entran en contacto directo con el cajón para calentar. Es posible que no pueda quitar el plástico derretido y esto no está cubierto por la garantía.

# CARE AND CLEANING

## FOR YOUR SAFETY

Before servicing or cleaning unit, switch power off at service panel and lock the service disconnecting means to prevent power from being switched on accidentally.

When the service disconnecting means cannot be locked, securely fasten a prominent warning device, such as a tag, to the service panel.

## MESH GREASE FILTERS AND DRIP TRAY (on some models)

Some models have 2 metal reusable grease filters and drip tray.

The metal filters and drip tray trap grease released by foods on the cooktop. The filters also help prevent flaming foods on the cooktop from damaging the inside of the hood.

For this reason, the filters must **ALWAYS** be in place when the hood is used. The grease filters and drip tray should be cleaned every 6 months, or as needed.

**To clean the drip tray**, drain and wipe all excess grease with a dry paper towel. Wash with hot soapy water. Dry with a clean cloth.

**To clean the grease filters**, soak them and then swish them around in hot water and detergent. Don't use ammonia or ammonia products because they will darken the metal. Do not use abrasives or oven cleaners. Light brushing can be used to remove embedded dirt. Rinse, shake and let them dry before replacing.

### To remove:

Grasp the filter lock and pivot it open to release. Pull the filter down and out. Remove both filters. Grasp the drip tray, on both sides, by the front edge and carefully lift it up and out.

### To replace:

1. Place and seat the drip tray into the hood track, making sure the rear tabs on the tray, hook into the back slots in the hood track.
2. Place the bottom of the filter in the lower hood rail.
3. Push the top of the filter back, open the filter lock and snap it into place.

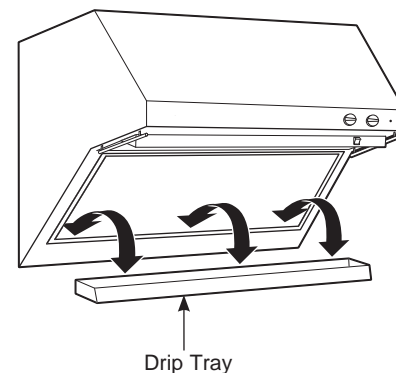
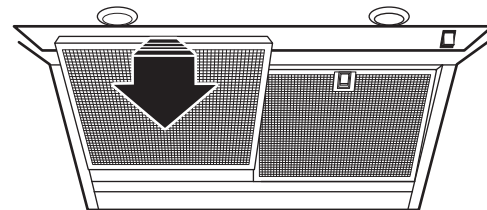
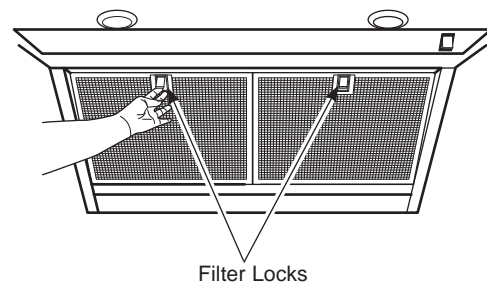
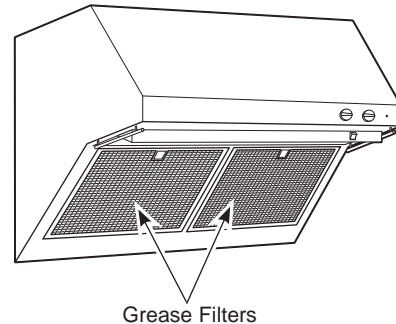



# CARE AND CLEANING

## BAFFLE GREASE FILTERS AND DRIP TRAYS (on some models)

Some models have reusable metal grease baffles and drip trays.

The metal baffles channel grease released by foods on the cooktop into the drip trays. The baffles also help prevent flaming foods on the cooktop from damaging the inside of the hood.

For this reason, the baffles must **ALWAYS** be in place when the hood is used. The grease baffles and drip trays should be cleaned once a month, or as needed.

**To clean the grease baffles and drip trays**, drain and wipe all excess grease with a dry paper towel. Soak them and then swish them around in hot water and detergent. Don't use ammonia or ammonia products because they will darken the metal. Do not use abrasives or oven cleaners. Rinse, shake and let them dry before replacing. **They may also be cleaned in an automatic dishwasher.**

### To remove:

Grasp the baffle knobs and pull them up, forward and out. Grasp the drip tray and carefully lift it up and out of the hood track.

### To replace the drip trays:

1. Place and seat the drip tray into the hood track.
2. Slide them left or right until all trays are side-by-side in place in the track.

### To replace the baffles:

1. Hold the baffle at the bottom by one of the knobs.
2. Place the other end of the baffle against the inside front of the hood.
3. Slide it up and push the bottom end back until it firmly seats into place.

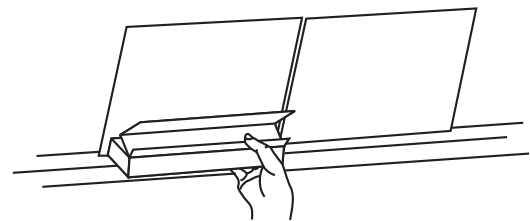
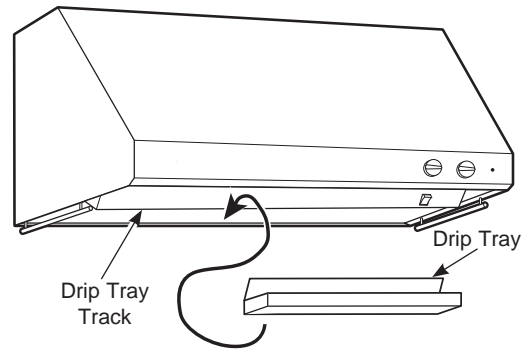

Drip Tray Replacement

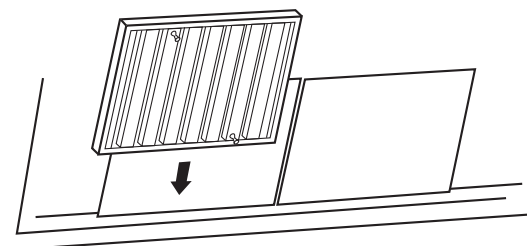
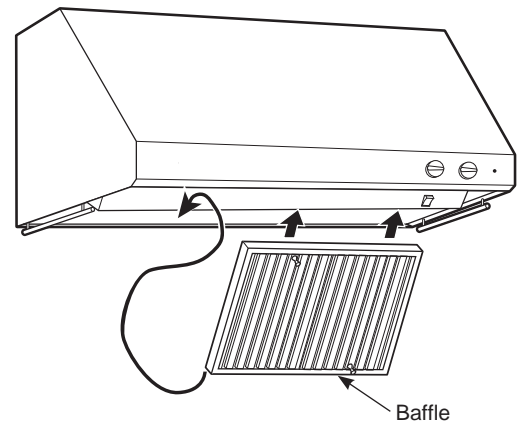

Baffle Replacement

# CARE AND CLEANING

## STAINLESS STEEL HOOD SURFACES (on some models)

Do not use a steel wool pad; it will scratch the surface.

To clean the stainless steel surface, use warm sudsy water or a stainless steel cleaner or polish. Always wipe the surface in the direction of the grain. Follow the cleaner instructions for cleaning the stainless steel surface.

To inquire about purchasing stainless steel appliance cleaner or polish, or to find the location of a dealer nearest you, visit [monogram.com](http://monogram.com) or call our toll-free number 800.444.1845.

---

## LIGHT BULBS

The bulbs are located on the underside of the hood.

To change the light bulbs:

1. Remove the trim ring by turning it counterclockwise.
2. Grasp the bulb on the edges and remove by turning it counterclockwise.
3. Replace with the same type and size bulb.

These 120 volt, 50 watt, par 16 halogen flood bulbs, with standard base, are available at specialty lighting stores.

These bulbs can also be ordered from your Monogram supplier.

Order bulb no. WB08X10028.

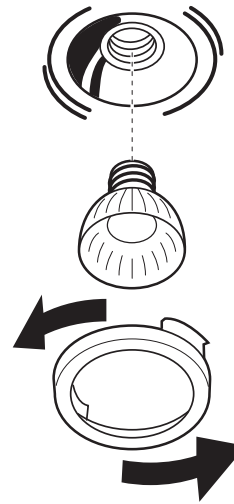

---

## WARMING LAMPS

The warming lamps are located on the underside of the hood.

These 120 volt, 175 watt, par 38 infrared heat lamp bulbs, with standard base, are available at some specialty lighting stores.

These infrared bulbs can also be ordered from your Monogram supplier.

Order bulb no. WB08X10029.

**NOTE:** If warming lamps are not desired, additional cooktop lighting can be obtained by replacing the infrared bulbs with standard incandescent bulbs with up to 100 watt maximum ratings, with standard bases. These bulbs are available at specialty lighting stores.

# TROUBLESHOOTING

Save time and money! Review the charts on the following pages first and you may not need to call for service.

Problem	Possible Cause	What To Do
<b>Fan and lights do not operate when the switches are turned on</b>	The hood was never electrically connected by the installer/electrician/builder.	Call the electrician/installer/builder to complete the installation. This is not covered by warranty.
	A fuse may be blown or a circuit breaker tripped.	Replace the fuse or reset the circuit breaker.
<b>The blower does not work but the lights do</b>	The blower motor wire harness was not connected or was not connected properly by the installer/electrician/builder to its mating connector located inside the hood on the top surface, to the left of the blower assembly.	<ol style="list-style-type: none"> <li>1. Switch power off at service panel and lock the service disconnecting means to prevent power from being switched on accidentally. When the service disconnecting means cannot be locked, securely fasten a prominent warning device, such as a tag, to the service panel.</li> <li>2. Remove the filters and locate the blower wire harness connector. Is it plugged into its mating connector?</li> <li>3. If no, plug the blower motor connector into its mating connector on the top of the hood. Switch the power back on. Check to see if the fan now works.</li> <li>4. If no, check the circuit breaker/fuse. If it is blown/tripped, replace/reset it. Does the blower work now? If no, call Monogram for service.</li> </ol>
<b>The blower fails to exhaust the smoke/steam/odors adequately</b>	Many factors could be the root cause for reduced air-flow.	
	Installation could be the problem.	Your hood was designed to meet specific ducting requirements. If your duct length exceeds the manufacturer's requirements, hood performance will suffer. Air-flow will also be reduced if the house duct work is too small or there are too many elbows in the system. Contact your installer or builder.
	Obstruction in duct work could be the problem.	Make sure nothing is blocking the vent (bird nests or kinks in the duct work).
	Damper blade may not be opening.	Make sure the tape is removed from the damper blades and that it swings open freely.
	Damper blade on Wall or Roof Cap may not be opening.	Contact your builder so they can make sure the damper swings open freely.
	Dirty filters/baffles	Make sure filters (and all hood surfaces) are kept clean of grease and dirt.
	Check to be sure the filter is clean.	If replacing the filter does not correct the problem, call for service.
	Sufficient makeup (replacement) air is required for exhausting appliances to operate to rating.	Check with local building codes, which may require or strongly advise the use of makeup air. Visit <a href="http://monogram.com">monogram.com</a> for available makeup air solutions.

# TROUBLESHOOTING

Problem	Possible Cause	What To Do
<b>The Halogen/Heat Lamp Does Not Work</b>	The lamp or socket may be defective or a wire could be disconnected.	<ol style="list-style-type: none"> <li>1. Do some trouble-shooting by removing the lamp and place it in the socket of a lamp that does work (the heat lamp will fit in the halogen socket for the purpose of checking it). Does it work now? If no, the lamp is defective. If your hood is still in-warranty, call Monogram service and ask them to mail out a new lamp. State clearly whether you need the halogen or the heat lamp. Lamps on this product are covered by warranty and are cataloged. If the hood is no longer covered by warranty, reference the Care and Cleaning section of this manual to see lamp requirements. Lamps can be purchased at home building stores, specialty lighting stores or through Monogram Parts. Reference the defective lamp for information as well.</li> <li>2. If you placed the lamp in a working socket and it does illuminate, the original socket may be defective or a wire may be disconnected. Call Monogram for service.</li> </ol>
<b>Part Is Missing/Damaged/ Defective</b>	In the unlikely event that a part would be missing, damaged or defective, we can serve you, the consumer, quickly by mailing these parts to you.	<p>We have identified several easy-to-install parts.</p> <p><b>These include:</b></p> <p>Lamps, lamp bezels, filters, baffles, grease trays, knobs, utensil rods, Owner's Manual and Installation Instructions.</p> <p>Call Monogram service and carefully describe your model number and the part you need. The model number is located inside the hood chassis, behind the filter/baffle.</p>
<b>Duct Cover Is Missing</b>	The duct cover is not included with the hood. It must be purchased as an accessory.	<ul style="list-style-type: none"> <li>■ 6" duct cover for use with a 30" or 36" hood—order kit #ZX36DC6</li> <li>■ 12" duct cover for use with a 30" or 36" hood—order kit #ZX36DC12</li> <li>■ 6" duct cover for use with a 48" hood—order kit #ZX48DC6</li> <li>■ 12" duct cover that works with a 48" hood—order kit #ZX48DC12</li> </ul> <p>Call Monogram Parts. See Consumer Service page in this manual for a list of phone numbers.</p>
<b>Installation Part Is Missing/ Damaged/ Defective</b>	Many factors could be the root cause for reduced air-flow.	<p>We provide a 10" round, vertical duct transition. This part can be mailed out to the hood installer if it is in some way unusable. All other duct transitions, elbows, etc must be purchased locally. We can also mail out many other parts that come with the hood to your installer. Call Monogram Service. See Consumer Service page in this manual for a list of phone numbers. Ask them to mail the parts only—no service call required.</p>

# MONOGRAM LIMITED WARRANTY

## Monogram.com

All warranty service is provided by our Factory Service Centers, or an authorized Customer Care® technician. To schedule service online, visit us at [monogram.com/contact](http://monogram.com/contact). In Canada, visit [monogram.ca](http://monogram.ca).

**Servicing your range hood may require the use of the onboard data port for diagnostics. This gives a Monogram Factory Service technician the ability to quickly diagnose any issues with your appliance and helps Monogram improve its products by providing Monogram with information on your appliance. If you do not want your appliance data to be sent to Monogram, please advise your technician NOT to submit the data to Monogram at the time of service.**

For the period of	Monogram Appliances will replace
Limited two-year warranty	For two years from date of original purchase, we will provide, free of charge, parts and service labor in your home to repair or replace any part of the vent hood that fails because of a manufacturing defect.

## What Monogram will not cover:

- Service trips to your home to teach you how to use the product.
- Replacement of house fuses or resetting of circuit breakers.
- Incidental or consequential damage caused by possible defects with this appliance.
- Replacement of the filters.
- Damage to the product caused by accident, fire, floods or acts of God.
- Failure of the product if it is used for other than its intended purpose or used commercially.
- Improper installation, delivery or maintenance.
- Damage caused after delivery.
- Product not accessible to provide required service.
- Installation or service for a makeup (replacement) air system.

### EXCLUSION OF IMPLIED WARRANTIES

Your sole and exclusive remedy is product repair as provided in this Limited Warranty. Any implied warranties, including the implied warranties of merchantability or fitness for a particular purpose, are limited to one year or the shortest period allowed by law.

This limited warranty is extended to the original purchaser and any succeeding owner for products purchased for home use within the USA. If the product is located in an area where service by a Monogram Authorized Servicer is not available, you may be responsible for a trip charge or you may be required to bring the product to an Authorized Monogram Service location for service. In Alaska, the limited warranty excludes the cost of shipping or service calls to your home.

Some states do not allow the exclusion or limitation of incidental or consequential damages. This limited warranty gives you specific legal rights, and you may also have other rights which vary from state to state. To know what your legal rights are, consult your local or state consumer affairs office or your state's Attorney General.

**Warrantor: GE Appliances, a Haier company, Louisville KY,40225**

**Warrantor in Canada: MC Commercial, Burlington, ON, L7R 5B6**

Staple your receipt here. Proof of the original purchase date is needed to obtain service under the warranty.

**49-2000855 Rev. 0**

10-20 GEA

Printed in Mexico

